

Operating manual

MultiControl AI / BI

Analogue Interface / Bus Interface – 24 V / 48 V DC



**UK
CA**

Manufacturer details

Interroll Software & Electronics GmbH
Im Südpark 183
4030 Linz
AUSTRIA

www.interroll.com

Content

We strive for the accuracy, timeliness and completeness of the information and have carefully prepared the contents in this document. Regardless of this, errors and changes are expressly reserved.

Copyright/industrial property rights

Any texts, images, graphics and the like, as well as their arrangement, are subject to protection under copyright and other laws of protection. The reproduction, modification, transmission or publication of any part of this document or of the entire document in any form is prohibited.

The document serves the exclusive purposes of information and of operation in accordance with the regulations and does not justify any counterfeiting of the products concerned.

All signs contained in this document (protected marks, such as logos and trade names) are the property of Interroll Holding AG, CH or of third parties and must not be used, copied or distributed without prior written consent.

Online version - only suitable for color printing!

Contents

1	About this document	7
1.1	Information about this operating manual	7
1.2	Warning notices in this document	8
1.3	Symbols	9
2	Safety-related information	10
2.1	State of the art	10
2.2	Proper use	10
	Application field	10
2.3	Improper use	11
2.4	Qualification of personnel	11
2.5	Dangers	12
	Injury to persons	12
	Electricity	12
	Work environment	12
	Faults in operation	12
	Maintenance	12
	Unintentional start-up	12
2.6	Interface to other devices	13
2.7	Functional safety	13
	Information on the performance level according to DIN EN ISO 13849-1: 2015	13
2.8	Operating modes/operating phases	14
	Standard operation	14
	Special operation	14
2.9	Applicable documentation	14
3	Product information	15
3.1	Product description	15
	Energy recovery/overvoltage protection	15
	Overload protection	15
3.2	Setup	16
	MultiControl AI and BI	16
	Base plate	17
3.3	Scope of delivery	17
3.4	Rating plate	18
3.5	Technical specifications	19
3.6	Dimensions	20

Contents

4	Transport and storage	21
4.1	Transport	21
4.2	Storage	21
5	Assembly and installation	22
5.1	Warning notices for installation	22
5.2	Assembling the MultiControl	22
	Initial assembly	22
	Subsequent assembly	24
5.3	Warning notices for electrical installation	25
5.4	Electrical installation	26
	Connecting the power supply	26
	Connecting the RollerDrive	27
	RollerDrive AI	27
	RollerDrive BI	27
	Connecting the bus	28
	Connecting the sensors	29
	Overview of connections	30
6	Start-up and operation	31
6.1	Start-up	31
	Check before the initial start-up	31
6.2	Configuration options	31
6.3	MultiControl user interface	32
	Prerequisites	32
	Starting the user interface	32
	"MultiControl Overview" home page	34
	Network Settings	35
	Motor Settings	36
	Motor Information – MultiControl BI only	38
	Motor Monitor – MultiControl BI only	39
	Motor Test for EC5000	40

Contents

	Digital I/O States	41
	Digital I/O Settings	42
	Control Program Settings	44
	Error State	45
	Error Handling Settings	45
	MultiControl Error Log	47
	Teach-in	48
	Plug&Play	48
	CAN Gateway	48
	Service Change Password	49
	Service Restore Factory Settings	49
	Service MultiControl Restart	50
	Service Version Information	50
	Service – Up-/Download	51
6.4	Magnetic sensor	52
6.5	Service data objects (SDO)	52
6.6	Operation	53
	Check before every start-up	53
	Start	53
	Stop	53
6.7	Procedure in the event of accidents or faults	54
7	Maintenance and cleaning	55
7.1	Maintenance	55
	Checking the MultiControl	55
	Replacing the MultiControl	55
7.2	Cleaning	56
8	Assistance in the event of faults	57
8.1	Understanding the LEDs	57
	General LEDs	57
	Connection LEDs	59
8.2	Troubleshooting	59
	Error codes	62

Contents

9	Decommissioning and disposal	65
9.1	Decommissioning	65
9.2	Disposal	65
10	Appendix	66
10.1	Accessories	66
10.2	Translation of the original Declaration of Conformity	67
10.3	UKCA Declaration of Conformity	68

1 About this document

1.1 Information about this operating manual

This operating manual describes the following versions of the Interroll MultiControl:

- Interroll MultiControl AI with analogue interface
- Interroll MultiControl BI with CANopen bus interface

Throughout this manual, the term "control system" is used as an alternative for referring to these models.

The operating manual is a component of the product and contains important advice and information regarding the different operating phases of the MultiControl. It describes the MultiControl at the time of shipping from Interroll.

The currently applicable version of this operating manual can be found online at:

www.interroll.com

All the information and advice in this operating manual has been compiled with respect to applicable standards and regulations as well as the current state of the art.

- To ensure safe and faultless operation and to fulfil any warranty claims that may apply, read this operating manual first and observe its instructions.
- Keep this operating manual within close reach of the MultiControl.
- Pass this operating manual onto every subsequent owner or user.



The manufacturer assumes no liability for damage and malfunctions that occur as a result of non-compliance with this operating manual.



Should you still have any unanswered questions after reading this operating manual, please contact Interroll customer service. Contact details for your region can be found online at www.interroll.com/contact/

Please direct any comments and suggestions regarding our operating manuals to manuals@interroll.com

About this document

1.2 Warning notices in this document

Warning notices are provided in the context in which danger can occur and describe the nature of the danger in question. They are structured according to the following examples:



SIGNAL WORD

Type and source of hazard

Consequence(s) in the event of non-compliance

➤ Measure(s) for avoiding hazard

Signal words indicate the type and severity of the consequences if measures to avoid the hazard are not observed.



DANGER

Denotes an imminent hazard.

If measures to avoid the hazard are not observed, death or severe injury will occur.

➤ Preventive measures



WARNING

Denotes a potentially hazardous situation.

If measures to avoid the hazard are not observed, death or severe injury may occur.

➤ Preventive measures



CAUTION

Denotes the possibility of a hazardous situation.

If measures to avoid the hazard are not observed, minor or moderate injury may occur.

➤ Preventive measures

NOTE

Denotes a situation that can lead to material damage.

- Preventive measures
-

1.3 Symbols



This symbol indicates useful and important information.

- ✓ This symbol indicates a requirement that must be fulfilled before carrying out assembly or repair work.



This symbol indicates general information relating to safety.

- This symbol indicates an action that needs to be performed.
- This symbol indicates a listed item.

Safety-related information

2 Safety-related information

2.1 State of the art

The Interroll MultiControl has been constructed with respect to applicable standards and the current state of the art and has been delivered in a condition that is safe to operate. Nevertheless, hazards can occur as a result of use.



Non-compliance with the instructions in this operating manual can result in life-threatening injuries.

In addition, the applicable local accident prevention regulations for the area of application and general safety regulations must be adhered to.

2.2 Proper use

The MultiControl may only be used in an industrial environment for industrial purposes within the stipulated performance limits that are given in the technical specifications.

It controls up to four Interroll RollerDrives or VDC motors and must be integrated into a conveyor unit or conveyor system before commissioning.



A suitable adapter must be used for connecting a VDC motor.

The MultiControl AI, 24 V DC can also be used to control the Interroll PalletControl.

Application field

The following applications are possible:

Use of a PLC	Function of a PLC	Function of the MultiControl
No	None	
Yes	<ul style="list-style-type: none">• Influence on ZPA logic• Tracking of material to be conveyed• Error diagnosis	Implementation of PLC specifications
Yes	<ul style="list-style-type: none">• The PLC program controls all connected RollerDrives• Tracking of material to be conveyed• Error diagnosis	Function as network card Sends the status of all sensors and the RollerDrive and, if necessary, error information to the PLC

2.3 Improper use

Any use that goes beyond the proper use is considered improper, unless this has been authorised by Interroll Engineering GmbH where applicable.

The equipment must not be installed in areas in which substances could form explosive atmospheres/dust atmospheres or for application in the medical/pharmaceutical sector.

It is considered improper use to install the equipment in exposed spaces that are open to potentially adverse weather conditions, or areas in which the technology would suffer from the prevailing climactic conditions and could potentially malfunction as a result.

The MultiControl is not intended for use by private end users. The equipment must not be used in a residential environment without further examination and without the use of EMC protective measures that have been adapted accordingly.

It must not be used as a safety-relevant component or for performing safety-relevant functions.

2.4 Qualification of personnel

Non-qualified personnel are unable to identify risks and are therefore exposed to higher levels of danger.

- Only qualified personnel may be assigned with the tasks outlined in this operating manual.
- The operating company is responsible for ensuring that personnel adhere to the locally valid rules and regulations for working in a safe and risk-aware manner.

This operating manual is intended for the following target audiences:

Operators

Operators are trained in how to operate and clean the Interroll MultiControl and follow the safety regulations.

Service engineers

The service engineers have a specialist technical education or have successfully completed a training course from the manufacturer. They carry out repair and maintenance work.

Qualified electricians

Qualified electricians have a specialist technical education. Moreover, due to their knowledge and experience as well as knowledge of applicable regulations, they are able to carry out work on electrical equipment in an appropriate manner. They are able to identify hazards independently and prevent electrical damage to persons and property.

All work on electrical equipment must generally only be performed by a qualified electrician.

Safety-related information

2.5 Dangers



Here, you will find information about the different types of dangers or damage that can occur in connection with the operation of the MultiControl.

Injury to persons

- Maintenance, installation and repair work on the unit must only be carried out by authorised technical personnel in compliance with the applicable provisions.
- Before switching on the MultiControl, ensure that no unauthorised personnel are situated in the vicinity of the conveyor/conveying system.

Electricity

- Installation and repair work must only be carried out when the system has been disconnected from the power supply. Switch off the power to the MultiControl and ensure that it cannot be unintentionally switched on again.

Work environment

- Remove any materials and objects that are not required from the working area.

Faults in operation

- Regularly check the MultiControl for visible damage.
- If smoke develops, immediately switch off the power to the MultiControl and ensure that it cannot be unintentionally switched on again.
- Immediately contact specialist personnel to determine the cause of the malfunction.

Maintenance

- Since the product in question requires no maintenance, it is sufficient to simply examine the MultiControl for visible damage on a regular basis.
- Never open up the MultiControl.

Unintentional start-up

- Ensure that the connected RollerDrives/motors cannot start up unintentionally, particularly during assembly and maintenance work or in the event of a fault.

2.6 Interface to other devices

The integration of the MultiControl into a conveyor system can create additional potential hazards. Such potential hazards are not covered by this operating manual and must be analysed during the development, installation and commissioning of the conveyor system as a whole.

- Following the integration of the MultiControl into a conveyor system, the entire system must be checked for any new potential hazards that may be present before the conveyor is switched on.

2.7 Functional safety

Information on the performance level according to DIN EN ISO 13849-1: 2015

The statistical analysis of the MultiControl AI / BI according to the „Part Counts Method“ has led to the following result if the maximum permissible ambient temperature of 40 °C is observed:

MTTF (h):

812691 Hours

MTTF (a):

93 Years

Provided that the behavior of the MultiControl is changed in the event of system-relevant errors in the “Error Handling Settings” of the MultiControl user interface, this results in an achievable performance level of “C” (see „Error Handling Settings“ on page 45).

Error Handling Settings	
System Errors	Control Errors
Network Error : Immediate Stop <input type="checkbox"/> ●	Control Error 1 : Ignore <input type="checkbox"/>
Over Voltage Error : Immediate Stop <input type="checkbox"/> ●	Control Error 2 : Ignore <input type="checkbox"/>
Under Voltage Error : Immediate Stop <input type="checkbox"/> ●	Control Error 3 : Ignore <input type="checkbox"/>
Motor Error : Immediate Stop <input type="checkbox"/> ●	Control Error 4 : Ignore <input type="checkbox"/>
General Control Error : Immediate Stop <input type="checkbox"/> ●	Control Error 5 : Ignore <input type="checkbox"/>
Sensor Error : Ignore <input type="checkbox"/>	Control Error 6 : Ignore <input type="checkbox"/>
	Control Error 7 : Ignore <input type="checkbox"/>
	Control Error 8 : Ignore <input type="checkbox"/>
	<input type="button" value="Submit"/> <input type="button" value="Reset"/>

In order to fulfill a safety function, the safety-related disconnection of the load voltage (motor voltage) is also required.

Safety-related information

2.8 Operating modes/operating phases

Standard operation

Operation in the installed condition at the end customer as a component in a conveyor in an overall system.

Special operation

Special operation encompasses all operating modes/operating phases that are necessary to guarantee and maintain safe standard operation.

Special operating mode	Comments
Transport/storage	-
Assembly/commissioning	In de-energised state
Cleaning	In de-energised state
Maintenance/repair	In de-energised state
Fault location	-
Troubleshooting	In de-energised state
Decommissioning	In de-energised state
Disposal	-

2.9 Applicable documentation

The MultiControl AI/BI is part of the **Interroll DC Platform**, consisting of:

- Interroll High Performance power supply unit HP5424 or HP 5448 (24 V DC/48 V DC)
- Interroll MultiControl AI/BI
- RollerDrive EC5000 AI/BI (24 V DC/48 V DC)
- Interroll DriveControl 20/54/2048



Also ensure that you adhere to the information given in the operating manuals of the connected devices.

Further notes on operating and programming the MultiControl can be found in the “MultiControl / RollerDrive - Start-up and Programming” supplement.

The latest version of this supplement can be found online at: www.interroll.com

3 Product information

3.1 Product description

The MultiControl is a control system for conveyor systems, which can control up to four Interroll RollerDrives. It is also a certified I/O device for PROFINET, EtherNet/IP and EtherCAT and can therefore be linked with other MultiControls and a PLC.

Sensors and RollerDrives can be directly integrated into the fieldbus level via the MultiControl. This completely eliminates the need for an additional sensor/actuator level.

Some applications are already pre-programmed in the MultiControl for applications with special conveying logic. It can therefore be used as a standalone control system – with or without connected PLC.

The MultiControl is compatible with all 24 V/48 V conveyor modules from Interroll Automation GmbH. So-called ZPA (zero pressure accumulation) programs are used for operating the conveyor modules with zero pressure accumulation.

The MultiControl BI communicates with the connected RollerDrive EC5000 BI via the CANopen protocol.



Further information on the integrated programs and functions can be found in accompanying document "MultiControl / RollerDrive - Start-up and Programming".

Energy recovery/overvoltage protection

If the RollerDrive is stopped or the speed is abruptly reduced, the kinetic energy of the conveyed material in the RollerDrive is converted into electrical energy, akin to a generator. This energy is fed back into the system, where it can be used by other RollerDrive units.

If more energy is fed back than can be used, the excess energy is converted into heat via a brake chopper in the MultiControl. The brake chopper is activated when the voltage rises above 28 V/52 V. This prevents excessively high voltages within the system.



Note the energy recovery capacity of the power supply units used.

We recommend the use of Interroll High Performance power supplies HP 5424 / HP5448 with a regenerative strength up to 35 V / 60 V.

With the MultiControl 24 V it is possible to reduce the brake chopper operating voltage to 26 V (see „Motor Settings“ on page 36).

Overload protection

If the brake chopper remains switched on for longer than two seconds, it is switched off again as it is assumed that the power supply unit is delivering an incorrect voltage. The activated overload protection is indicated by the LED display. Whenever the overload protection is active, the motors cannot be switched on.

The MultiControl does not provide a protective mechanism against excess temperature in the connected RollerDrive.

Product information

3.2 Setup

MultiControl AI and BI

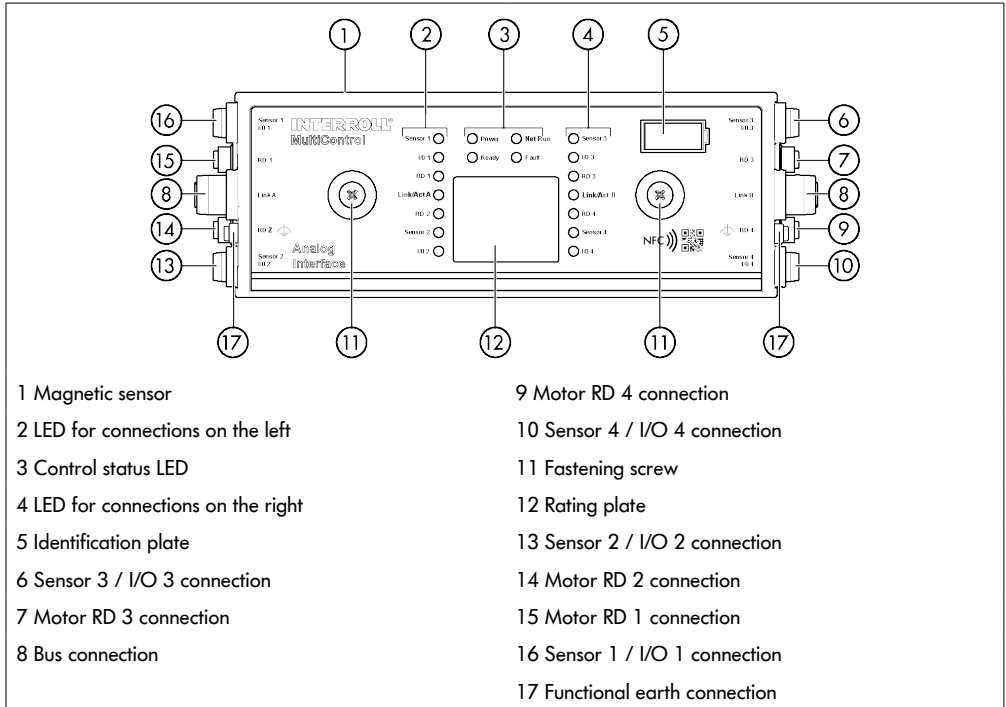

1 Magnetic sensor

2 LED for connections on the left

3 Control status LED

4 LED for connections on the right

5 Identification plate

6 Sensor 3 / I/O 3 connection

7 Motor RD 3 connection

8 Bus connection

9 Motor RD 4 connection

10 Sensor 4 / I/O 4 connection

11 Fastening screw

12 Rating plate

13 Sensor 2 / I/O 2 connection

14 Motor RD 2 connection

15 Motor RD 1 connection

16 Sensor 1 / I/O 1 connection

17 Functional earth connection

Base plate

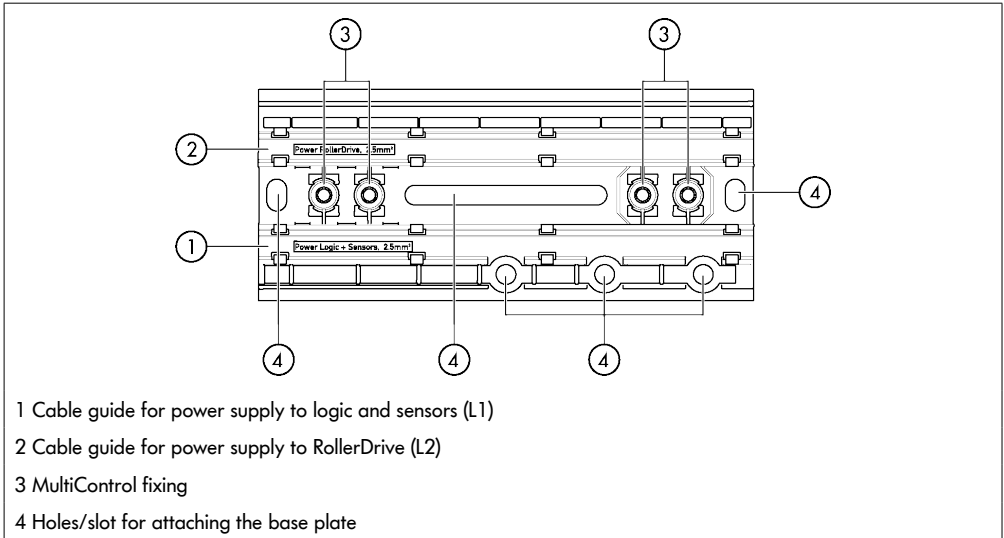

3.3 Scope of delivery

The scope of delivery of the MultiControl includes the following parts:

- MultiControl
- Base plate
- Two screws for attaching the MultiControl to the base plate

Product information

3.4 Rating plate

The information on the rating plate allows the MultiControl to be identified. This is essential to be able to use the MultiControl as intended.

The diagram shows a rectangular rating plate with the following information and callouts:

- 1: Article number (1103563)
- 2: MAC address (00:02:A2:27:0D:C9)
- 3: Week/year of production (08 / 2017)
- 4: Manufacturer (Interroll Software & Electronics GmbH, 4030 Linz - Austria, www.interroll.com)
- 5: Serial number (0000523)
- 6: UL marking (UL US LISTED)
- 7: CE marking (CE)
- 8: Connection data (L1: 24V^{DC}, 1.6A; Digital I/O: 24V^{DC}, max 0.8A total; L2: 24V^{DC}, 1.4A; Sensor Supply: 24V^{DC}, max 0.6A total; L2: 48V^{DC}, 7A)

Additional markings include 'Ind. Cont. Eq. E496888' and '10340876xx'.

1 Article number	5 Serial number
2 MAC address	6 UL marking
3 Week/year of production	7 CE marking
4 Manufacturer	8 Connection data

The diagram shows an NFC chip icon with callout 9 and a QR code with callout 10.

9 Reference to NFC chip in the label	10 QR Code
--------------------------------------	------------

Product-specific data can be read out via the Interroll Product App and the NFC chip integrated into the type plate. The Interroll Product App is available in all well-known app stores:



3.5 Technical specifications

Rated voltage for logic and sensors (L1)	24 V DC, protected extra-low voltage (PELV)					
Voltage range L1	22 to 27,5 V DC					
Rated voltage for RollerDrive (L2)	24 V DC, protected extra-low voltage (PELV)	48 V DC, protected extra-low voltage (PELV)				
Voltage range L2	22 to 27,5 V DC	44 to 51,5 V DC				
Current consumption	<p>Logic supply voltage L1:</p> <p>MultiControl: Max. 0.2 A + connected sensors/actuators = max. 1.6 A</p> <p>RollerDrive supply voltage L2:</p> <table border="1"> <tr> <td>RollerDrive rated current: Max. 4 x 3.5 A = 14.0 A</td> <td>RollerDrive rated current: Max. 4 x 1.75 A = 7.0 A</td> </tr> <tr> <td>RollerDrive starting current: Max. 4 x 7.5 A = 30.0 A</td> <td>RollerDrive starting current: Max. 4 x 3.8 A = 15.2 A</td> </tr> </table>		RollerDrive rated current: Max. 4 x 3.5 A = 14.0 A	RollerDrive rated current: Max. 4 x 1.75 A = 7.0 A	RollerDrive starting current: Max. 4 x 7.5 A = 30.0 A	RollerDrive starting current: Max. 4 x 3.8 A = 15.2 A
RollerDrive rated current: Max. 4 x 3.5 A = 14.0 A	RollerDrive rated current: Max. 4 x 1.75 A = 7.0 A					
RollerDrive starting current: Max. 4 x 7.5 A = 30.0 A	RollerDrive starting current: Max. 4 x 3.8 A = 15.2 A					
Protection rate	IP54 (not UL-tested)					
Degree of contamination	2					
Weight	500 g (incl. base plate)					
Ambient temperature in operation	-30 °C to +40 °C					
Ambient temperature during transport and storage	-40 °C to +80 °C					
Max. temperature change	1 K/min, 3 h, 2 cycles					
Max. relative humidity	93% at +40 °C, 14 days, non-condensating					
Altitude of installation site	<p>Max. 1000 m</p> <p>In principle, it is possible to install the equipment at altitudes higher than 1000 m. However, this may reduce the performance values.</p>					

4 Transport and storage

4.1 Transport



CAUTION

Risk of injury from improper transport.

- Transport operations must only be carried out by authorised, qualified personnel.
-

Please note the following:

- Do not stack pallets on top of one another.
- Prior to transport, check whether the MultiControl is correctly attached.
- Avoid heavy impacts during transport.
- Check each MultiControl after transport for any visible damage.
- If any damage has been identified, photograph the damaged parts.
- In the event that damage has been incurred during transport, inform the shipping agent or Interroll immediately to ensure that you do not lose any potential damage claims.
- Do not expose the MultiControl to any strong fluctuations in temperature, since this can lead to condensation forming.

4.2 Storage



CAUTION

Risk of injury due to improper storage.

- Ensure that the MultiControl is stored safely.
-

Please note the following:

- Do not stack pallets on top of one another.
- Check each MultiControl after storage for any visible damage.

Assembly and installation

5 Assembly and installation

5.1 Warning notices for installation

NOTE

An improper approach to installing the MultiControl can lead to material damage or reduce the service life of the MultiControl.

- To preserve the interior of the MultiControl, do not allow the MultiControl to fall or for it to be used in an improper fashion.
- Check each MultiControl before assembly for any visible damage.
- Ensure that the MultiControl is not tensioned during the assembly process (no bending or torsional load).
- Do not drill any additional mount holes into the housing or the base plate and do not enlarge any existing holes.

5.2 Assembling the MultiControl

Initial assembly

To attach the MultiControl to the conveyor frame, the base plate provided must first be mounted on the conveyor frame. There are two sets of two holes in the base plate for attaching the MultiControl. The holes on the left should be used for initial assembly.



To simplify electrical installation, all MultiControls should only be attached to one side of the conveyor system if possible. In the case of curves, the MultiControls should be attached as close to the outer radius of the curve as possible, as the RollerDrive connection is on this side.

- Find a level surface on the conveyor frame where the MultiControl can be attached. Leave approximately 25 mm to the left of this to enable the MultiControl to subsequently be moved if necessary (see „Subsequent assembly“ on page 24).
- Use the base plate as a template and mark the middle of the installation holes. Ensure the correct orientation of the base plate (the cable guide label must be legible).

Assembly and installation

- Drill two holes with a diameter of 6.5 mm through the markings in the conveyor frame.
- Attach the base plate to the conveyor frame with M6 screws.
- Make sure the base plate has not been distorted.
- Insert the ribbon cables for the power supplies (see „Connecting the power supply“ on page 26).
- Place the MultiControl on the left-hand holes and press it down until the lock engages.



- Screw the MultiControl onto the base plate (max. tightening torque 2,5 - 2,75 Nm). This drives the piercing contacts through the ribbon cable and makes contact with the power supplies.



Use the screws provided to attach the MultiControl to the base plate.

Assembly and installation

Subsequent assembly

If a MultiControl that has already been connected needs to be detached from the base plate, the ribbon cables must not make contact again at the same point, as otherwise proper contact cannot be guaranteed. So as not to have to disconnect the ribbon cables from all MultiControls and then reconnect them, in this case the MultiControl can be attached via the installation holes on the right.



5.3 Warning notices for electrical installation



CAUTION

Risk of injury when working on electrical equipment.

- Electrical installation work must only be carried out by a qualified electrician.
- Before installing, removing or connecting the MultiControl, switch off the power to the conveyor system and ensure that it cannot be unintentionally switched on again.
- Set all the power supplies used to the same earth potential in order to avoid compensating currents via the MultiControl or bus cable.
- Ensure all components are earthed correctly. Improper earthing can lead to a build-up of static charge, which can result in a fault or premature failure of the MultiControl.
- Ensure that suitable switching devices and protective systems are in place that will allow the equipment to be operated safely.
- Only switch on the operating voltages when all cables are connected.

NOTE

Improper electrical installation can result in damage to the MultiControl.

- Observe national regulations for electrical installation.
- Only operate the MultiControl with a protective extra-low voltage (PELV) of 24 V or 48 V.
- Never operate the MultiControl with an alternating voltage.
- Ensure that the polarity of the power supply is correct.
- Ensure that the existing electrical installation has no disruptive influence on the MultiControl.
- Only use cables that are adequately dimensioned for the specific operating conditions.
- Ensure that the calculations for the drop in voltage in the cables are taken into account.
- Observe regulations for laying cables.
- Do not expose the connectors to excessively high tensile or pressure loads. If the connector cable is bent, this can damage the cable insulation and cause the MultiControl to fail.

Assembly and installation

5.4 Electrical installation

Connecting the power supply

Two type 3G3G-FL ribbon cables with a wire cross-section of $2 \times 2.5 \text{ mm}^2$ are used for the power supplies.

By using two ribbon cables, the RollerDrives and the sensors/logic have a separate voltage supply. This enables the RollerDrives to be safely shut down without interrupting bus communication.



A ribbon cable distributor can be used to enable the MultiControl to be used as a replacement part in existing systems (see „Accessories“ on page 66).

Both earth potentials (L-) of the power supplies are connected to one another in the MultiControl.

- Insert the ribbon cables with the correct orientation, without mechanical tension or torsion, into the cable guides on the base plate. The cable guides have a form-fit design (see figure). This means that the ribbon cables can only be inserted with the correct orientation and the polarity of the cables cannot be reversed.
- If necessary, implement appropriate strain relief and vibration reduction measures.

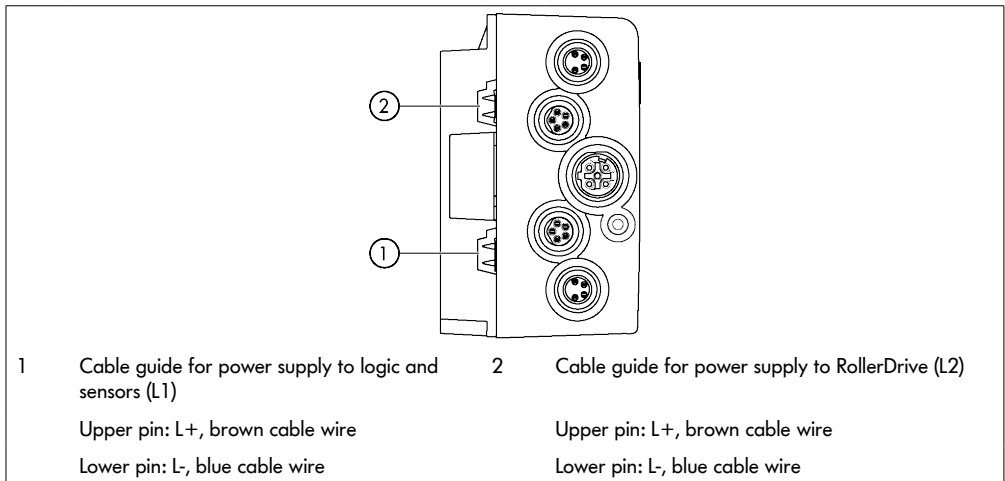

- Seal the ends of the ribbon cables with end caps to achieve protection rate IP54.
- Mount the MultiControl on the base frame to establish contact (see „Initial assembly“ on page 22).
- Connect the cables to the power source. Connect the brown wire to L+ and the blue wire to L-.

Connecting the RollerDrive

RollerDrive AI

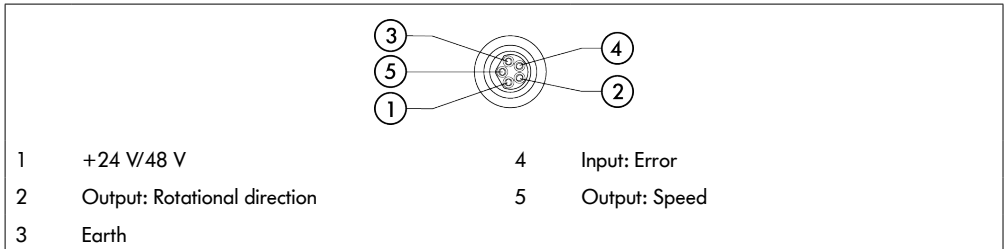

- Seal unused RollerDrive connections with an M8 blind cap to achieve protection rate IP54.

RollerDrive BI

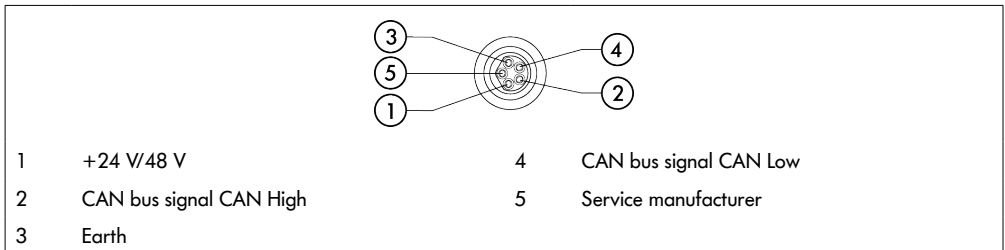

- Seal unused RollerDrive connections with an M8 blind cap to achieve protection rate IP54.

NOTE

Incorrect connected loads can destroy the RollerDrive.

- Do not attempt to operate a RollerDrive EC5000 24 V DC at 48 V DC. This will destroy the motor electronics.

NOTE

Connecting/disconnecting under voltage can destroy the MultiControl / RollerDrive EC5000 with bus interface

- The MultiControl and the RollerDrive EC5000 BI are not hot-plug-compatible. Disconnect the power supply to connect/disconnect the RollerDrive EC5000 BI.

Assembly and installation

Connecting the bus

Connections "Link A" and "Link B" are suitable for M12 connectors, four-pin, D-coded, contact assignment as per IEC 61076-2-101.

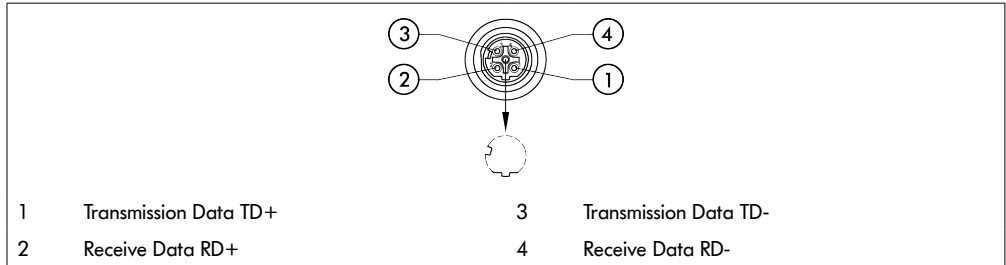

The MultiControl features an integrated two-port switch. This enables the MultiControl to be integrated into line structures of the bus wiring, for example.

- Observe the installation guidelines for the corresponding bus systems:
 - PROFINET: PROFIBUS & PROFINET International (PI), www.profibusb.com
 - EtherCAT: EtherCAT Technology Group, www.ethercat.org
 - EtherNET/IP: ODVA, www.odva.org
- Seal any unused connections with an M12 blind cap to achieve protection rate IP54.



It is possible to connect the shielding of the bus cables on both sides of the MultiControl. This minimises EMC problems.

Connecting the sensors

Four sensors and four additional inputs or outputs (AUX I/O) can be connected at connections "Sensor 1, I/O 1" to "Sensor 4, I/O 4". PNP or NPN sensors as well as sensors with N/C or N/O contact can be used. The sensor type and the function of the additional I/Os can be parametrised (see „Digital I/O - Settings“ on page 42). A Y-cable can be used to connect a sensor and an input/output at the same connection (see „Accessories“ on page 66).

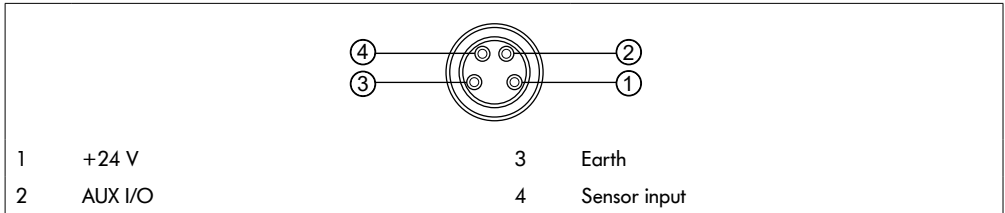

- Seal any unused connections with an M8 blind cap to achieve protection rate IP54.

NOTE

Connections are not short circuit-proof

In the event of a short circuit, particularly between Pin 1 and Pin 3, the internal fuse (PTC) in the MultiControl trips. Standard operation can be resumed once the internal fuse has cooled down.

- Ensure the correct polarity.



The inputs and outputs are not galvanically separated.

Characteristic values for the inputs

Input voltage	0 V to 24 V DC
Input resistance	≥ 15 kΩ
Switching thresholds	≥ 15 V "High" ≤ 5 V "Low"

Assembly and installation

Characteristic values for the outputs	
Output voltage	24 V DC
Maximum output current	≤ 200 mA
Output voltage "1" for PNP	> 15 V at 200 mA
Output voltage "1" for NPN	≤ 5 V at 200 mA

- Seal any unused sensor connections with an M8 blind cap to achieve protection rate IP54.

Overview of connections

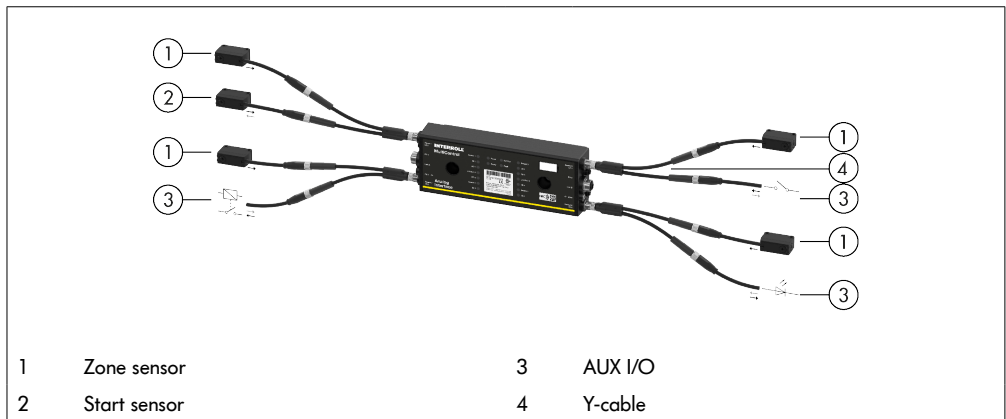

6 Start-up and operation

6.1 Start-up

Check before the initial start-up

- Ensure that the base plate of the MultiControl has been correctly attached to the profile, that the MultiControl has been correctly attached to the base plate and that all screws have been properly tightened.
- Ensure that no additional hazards are formed through the interfaces to other components.
- Ensure that the wiring conforms to the specifications and legal provisions.
- Check all protective equipment.
- Ensure that no persons are in the hazardous areas by the conveyor system.

6.2 Configuration options



CAUTION

Risk of malfunction!

- Change the motor configuration via SDO or web browser only when motors are stopped!

The MultiControl must be configured before it can be started up. There are various ways of doing this:

- All settings can be configured via a web-based user interface on a computer connected to the MultiControl.
- Directly on the MultiControl via the built-in magnetic sensor (see the “MultiControl / RollerDrive - Start-up and Programming” supplement).
- All settings except the bus type can be configured via service data objects (SDOs) written by a higher-level control system (see the “MultiControl / RollerDrive - Start-up and Programming” supplement).
- The station name, the IP configuration and the connection settings can be modified via a PLC development environment.
- The data is automatically transferred by the Plug&Play function when the MultiControl is replaced.

NOTE

Possible loss of data during the start process

If the supply voltage is interrupted during the start process, this can result in a loss of data.

- Do not switch off the supply voltage during the start process (approx. 10 seconds).

Start-up and operation

6.3 MultiControl user interface

The MultiControl has an integrated web server that generates a user interface for configuring the MultiControl. This user interface can be opened on a computer connected to the MultiControl.

Except for a web browser, no further software needs to be installed on the computer.

Prerequisites

The following prerequisites must be fulfilled in order to start the web-based user interface:

- The MultiControl has a valid IP address that is known (default setting: IP address 192.168.0.1, subnet mask 255.255.255.0).
- The connected computer must be in the same IP range (see system description/network settings for the PC).
- There is an Ethernet connection between the MultiControl and the computer.
- Port 80 can be accessed (user interface is HTTP-based).
- The MultiControl is not configured for EtherCAT, as EtherCAT does not permit HTTP communication. The bus type can be read using the magnetic sensor (see the "MultiControl / RollerDrive - Start-up and Programming" supplement).

Starting the user interface

- Start the web browser on the computer connected to the MultiControl.
- In the address line, enter the IP address of the MultiControl (default setting: <http://192.168.0.1/>).
- On the login page, enter the login data (default setting: User name "Interroll", password "Interroll").



Unless otherwise specified, the figures apply to the MultiControl AI and the MultiControl BI.

Start-up and operation

MultiControl AI

The screenshot displays the MultiControl AI web interface. On the left is a vertical navigation menu with the following items: Overview (highlighted), Network and Settings, Motor, Settings, TestPanel, Digital I/O, States, Settings, Control Program, Settings, Error, State, Settings, Log, Service, Teach-In, Plug&Play, System, Change Password, Factory Reset, Restart, Version, Up-/Download, and Log Out. The main content area is titled "MultiControl Overview" and contains the following information:

- Bus Info**
Bus Protocol : PROFINET
Host Name : multicontrol2
IP Address : 192.168.0.2
State : Disconnected
- Error Info**
State : Operational
Active Error : BusConfal (21)
Last Error : 00:00:42.536.21 BusConfal
- Control Program Info**
Program ID : I/O Device
Version : 2017-04-10-09
- Find Device**
Start Identity

MultiControl BI

The screenshot displays the MultiControl BI web interface. On the left is a vertical navigation menu with the following items: Overview (highlighted), Network and Settings, Motor, Information, Monitor, TestPanel, Digital I/O, States, Settings, Control Program, Settings, Error, State, Settings, Log, Service, Teach-In, Plug&Play, CAN Gateway, System, Change Password, Factory Reset, Restart, Version, Up-/Download, and Log Out. The main content area is titled "MultiControl Overview" and contains the following information:

- Bus Info**
Bus Protocol : PROFINET
Host Name : multicontrol2
IP Address : 192.168.0.2
State : Disconnected
- Error Info**
State : Operational
Active Error : BusConfal (21)
Last Error : 00:00:42.536.21 BusConfal
- Control Program Info**
Program ID : I/O Device
Version : 2017-04-10-09
- Find Device**
Start Identity

Use the menu on the left-hand side of the screen to navigate through further information and settings.

Start-up and operation

“MultiControl Overview” home page

MultiControl Overview

Bus Info

Bus Protocol : PROFINET
Host Name : multicontrol2
IP Address : 192.168.0.2
State : Disconnected

Error Info

State : Operational
Active Error : BusComFail (21)
Last Error : 00:00:42.536.21 BusComFail

Control Program Info

Program ID : I/O Device
Version : 2017-04-10-09

Find Device

Start Identify

The following information is displayed on the home page:

- Information regarding the set bus system
- Information regarding the most recent error
- Information regarding the set application program

“Start Identify” button

Starts a “running light” of all LEDs in order to identify the MultiControl in the conveyor.



The EDS file for the respective software version is stored on the MultiControl and can be downloaded via the link at the bottom of the home page.

- To exit the user interface, click on “Log Out” (not necessary if the MultiControl is restarted).

Network Settings

Network Settings

Bus Protocol
 EtherCAT
 EtherCAT BI
 EtherCAT/CAN
 EtherCAT/CAN Pro
 PROFINET
 EtherNet/IP

Addresses
IP address : 192.168.0.1
Network Mask : 255.255.255.0
Gateway : 0.0.0.0

Domains
Host Name : multicontrol
Domain Name :
DNS server 1 : 0.0.0.0
DNS server 2 : 0.0.0.0

Configuration Mode
 Static
 I/O Controller

Neighbours
IP address upstream : 192.168.0.16
IP address downstream : 192.168.0.17

Option
 Big Endian Format
Process Image In/Out: Universal Full / Universal Full

Submit Reset

In order to integrate the MultiControl into an automation system, bus parameters may also need to be modified. This includes the setting for the bus type used as well as addressing.

The MultiControl supports the following bus types:

- PROFINET I/O device – Conformance Class B, Netload Class 1
- EtherNet/IP slave
- EtherCAT slave

The following parameters can be modified in order to address the MultiControl:

- IP address and subnet mask
- Gateway
- Host name: When using the MultiControl with PROFINET, the unique PROFINET name of the MultiControl must be entered here
- Domain name plus DNS server 1 and 2
- Configuration mode of the address:
 - Static: The IP address is assigned by the user
 - I/O controller: The IP address is assigned by the PLC (input field is greyed out)



To avoid communication problems in the bus system, we recommend changing the standard IP address 192.168.0.1.

Depending on the system configuration, in PROFINET projects we recommend manually increasing the update time of the MultiControl (automatic 2 ms) to half the CPU cycle time or at least 8 ms.

Start-up and operation

- IP addresses of neighbouring MultiControls (with ZPA and ZPA+ programs)
IP address upstream: Address of the MultiControl from which articles, trays, materials to be conveyed, products, etc. are transferred
IP address downstream: Address of the MultiControl to which articles, trays, materials to be conveyed, products, etc. are delivered
- Definition as to whether the PLC data is in big-endian format (High/Low byte switched)



Press the "Submit" button to transfer the modified parameters to the MultiControl.

NOTE

Irreparable damage to the MultiControl due to premature shutdown of the supply voltage

- Ensure that the power supply is not interrupted during the entire process of changing the bus type until the restart is complete. This process takes approx. two minutes.

Motor Settings

Motor Settings				
	Motor 1	Motor 2	Motor 3	Motor 4
Motor Type	EC5000	EC5000	Disabled	Disabled
Roller Diameter [mm]	50.0	50.0	50.0	50.0
Gearing Ratio	49:1	49:1	none	none
Direction	<input checked="" type="radio"/> CW <input type="radio"/> OCCW	<input checked="" type="radio"/> CW <input type="radio"/> OCCW	<input checked="" type="radio"/> CW <input type="radio"/> OCCW	<input checked="" type="radio"/> CW <input type="radio"/> OCCW
Normal Speed [m/s]:	1.00	1.00	1.00	1.00
Alternate Speed [m/s]:	0.50	0.50	0.50	0.50
Acceleration [m/s ²]:	0.00	0.00	0.00	0.00
Deceleration [m/s ²]:	0.00	0.00	0.00	0.00
<input type="checkbox"/> Apply Motor 1 Settings to all				
Avoid parallel Motor Start/Stop - ZPA				
Start Delay [ms]:	100			
Stop Delay [ms]:	100			
<input checked="" type="radio"/> 28 V Brake Chopper Level: <input type="radio"/> 26 V				
			<input type="button" value="Submit"/>	<input type="button" value="Reset"/>



CAUTION

Risk of malfunction!

- Change the motor configuration via web browser only when motors are stopped!

- Deactivate unused motors to avoid error messages.
- Select the connected motor – EC5000 / EC310 / VDC Speed / VDC Position



If a motor is activated but not connected, the RD1 – RD4 LED flashes.

- Enter the “Roller diameter”, “Gearing ratio” and “Normal speed” according to the RollerDrive used.



In the case of conical rollers (curves), enter the average roller diameter as the diameter.

In the “I/O device” control program, the speed in % relates to the value set here under “Normal speed”.

Due to tolerances and / or voltage drop on cables, it is possible that the RollerDrive does not rotate when it is set to its minimum values. In this case a higher setting and thus speed must be selected.

The “Direction” parameter is used to adapt the rotational direction of the RollerDrive to the installation location (rotational direction as viewed from the cable end of the RollerDrive).

“Acceleration” and “Deceleration” adapt the start/stop behaviour of the RollerDrive. The “Alternate speed” parameter is not currently in use.

Acceleration values for the RollerDrive EC5000 BI

The optimum acceleration ramp for the EC5000 BI is achieved by entering the following acceleration values.

Gear	9:1	13:1	18:1	21:1	30:1	42:1	49:1	78:1	108:1
Acceleration value m/s ²	13,2	9,2	6,6	5,7	4,0	2,8	2,4	1,5	1,1

Avoid parallel Motor Start/Stop - ZPA

Start Delay: The connected RollerDrives are started one after the other at the set time interval to prevent overloading the power supply when it is switched on.

Stop Delay: The connected RollerDrive are stopped one after the other at the set time interval to prevent overloading the power supply when it is switched off.

Brake Chopper Level

For the MultiControl 24 V AI/BI, the brake chopper operating voltage can be reduced to 26 V.
The factory setting is 28 V.



Press the “Submit” button to transfer the modified parameters to the MultiControl.

Start-up and operation

Motor Information – MultiControl BI only

Motor Information				
	Motor 1	Motor 2	Motor 3	Motor 4
Gear Ratio	49:1	49:1	---	---
Max. Speed [m/s]	0.37	0.37	---	---
Status	Stop	Stop	N.C.	N.C.
Motor Name	EC5000	EC5000	---	---
Hardware Vers.	1.0000	1.0000	---	---
Software Vers.	0.11.07	0.11.07	---	---
Product Code	---	---	---	---
Serial Number	381	---	---	---

Display of motor data:

- Gear ratio
- Maximum speed
- Rated power
- Status
- Motor name
- Hardware version
- Software version
- Product code
- Serial number

Motor Monitor – MultiControl BI only

Motor Monitor				
	Motor 1	Motor 2	Motor 3	Motor 4
Lifetime				
Temperature				
Power				
Error				
Start/Stops	177	31536065	---	---
Run Time (hh:mm:ss)	0:19:42	3140:26:15	---	---
Up Time (hh:mm:ss)	288:45:16	8984:58:28	---	---
Temp. Max (°)	46	99	---	---
Temp. Min (°)	16	16	---	---
Current Temp. (°)	21	20	---	---
Num. Quick Stops	0	0	---	---
Actual Torque (mNm)	0	0	---	---
Power/Time (Wh)	0	0	---	---
Num. Rotations	2174	172911880	---	---

Visual displays

Service life indicator lights

Health indicator lights for:

- Temperature
- Power
- Frequency of errors

Monitoring data

Start/stops – Number of start/stops per minute

Run time (s)

Up time (s)

Temp. max (°C) – Maximum temperature of the motor electronics

Temp. min (°C) – Minimum temperature of the motor electronics

Current temp. (°C) – Actual temperature of the motor electronics

Num. quick stops – Number of quick stops

Actual Torque (mNm) - Actual Torque

Power/time (Wh) – Average mechanical power output

Num. rotations – Number of motor revolutions

Start-up and operation

Motor Test for EC5000



WARNING

Risk of crushing due to unintentional start-up of the RollerDrive!

- Changes in this menu have direct influence on the connected RollerDrive!
- Before starting motors make sure, ensure that no persons are present in the hazardous areas surrounding the conveyor system!

Motor Test for EC5000

Simple Test

Start all motors in positive direction

Select effected Motors

- Motor 1
- Motor 2
- Motor 3
- Motor 4

Motor Commands

Velocity Mode:

- Select the desired motor
- Select the test:
 - Simple test – Starts all connected motors in a positive rotational direction
 - Velocity mode – Start and stop selected motors clockwise or anti-clockwise

Digital I/O States

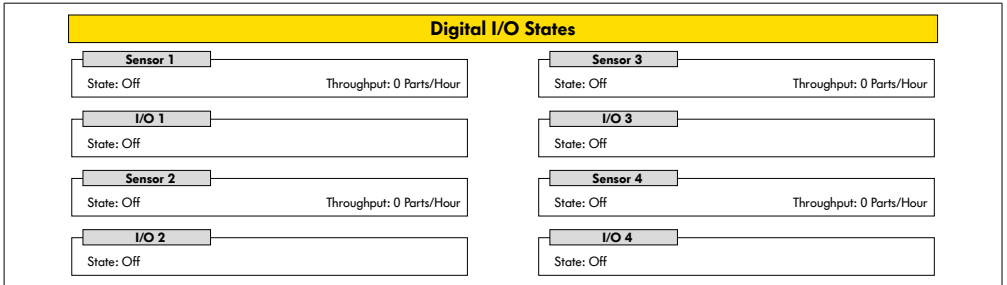

Display of the switching states of the connected sensors and I/Os.

Throughput

Based on the sensor signals, the throughput of the individual zones is determined.

For this, the signals of the last five minutes are extrapolated to one hour.

This means that the system must have been running for at least five minutes.

The counters are active in all operating modes.



Not a real-time status. Status changes are only visible once the web browser has been refreshed ("F5" key).

Start-up and operation

Digital I/O Settings

Digital I/O Settings

Sensor 1

Type : PNP NPN

Polarity : positive negative

ON Delay [ms] :

OFF Delay [ms] :

Sensor 3

Type : PNP NPN

Polarity : positive negative

ON Delay [ms] :

OFF Delay [ms] :

I/O 1

Type : PNP NPN

Polarity : positive negative

Function : ▼

I/O 3

Type : PNP NPN

Polarity : positive negative

Function : ▼

Sensor 2

Type : PNP NPN

Polarity : positive negative

ON Delay [ms] :

OFF Delay [ms] :

Sensor 4

Type : PNP NPN

Polarity : positive negative

ON Delay [ms] :

OFF Delay [ms] :

I/O 2

Type : PNP NPN

Polarity : positive negative

Function : ▼

I/O 4

Type : PNP NPN

Polarity : positive negative

Function : ▼

I/O State LEDs enabled
 Shutdown Aux Output

Submit
Reset

Sensors 1–4 are assigned to the zone sensors.

Additional I/Os can be connected by using an optional Y-cable.

I/O 1 to I/O 4 can be configured as inputs or outputs with the following functions:

Function	Description
None	-
PLC input	Input signal from the PLC
PLC output	Output signal to the PLC
Sensor 5	Start sensor zone 1 (polarity must be negative)
Sensor 6	Spare
Sensor 7	Spare
Sensor 8	Spare
Control input 1	Stops zone 1
Control input 2	Stops zone 2
Control input 3	Stops zone 3
Control input 4	Stops zone 4
Control input 5–8	No function
Control output 1	Zone 1 occupied
Control output 2	Zone 2 occupied

Function	Description	
Control output 3	Zone 3 occupied	
Control output 4	Zone 4 occupied	
Control output 5–8	No function	
Handshake in up	Handshake signals to neighbouring ZPA modules	
Handshake in down		
Handshake in left		
Handshake in right		
Handshake out up		
Handshake out down		
Handshake out left		
Handshake out right		
VDC motor #1 error in		VDC motor error input
VDC motor #2 error in		
VDC motor #1 direction out	VDC motor directional rotation	
VDC motor #2 direction out		
VDC motor #1 step pulse out	VDC motor pulse output	
VDC motor #2 step pulse out		

The functions have no influence on the "I/O device" control program.

Shutdown Aux Output

- | | |
|---------------|---|
| Not activated | The aux outputs are reset when the RollerDrive voltage is switched off and cannot be controlled. |
| Activated | The Aux outputs keep their current status when the RollerDrive voltage is switched off and can still be controlled. |



The functions vary depending on the selected control program (see the description of control programs in the "MultiControl / RollerDrive - Start-up and Programming" supplement).

Press the "Submit" button to transfer the modified parameters to the MultiControl.

Start-up and operation

Control Program Settings

Control Program Settings

Control Program Settings
Program ID : I/O_Device
Version : 2017-12-11

Control Timer
Timer 1 [ms] :
Timer 2 [ms] :
Timer 3 [ms] :
Timer 4 [ms] :

Selection of control programs

ZPA single release program ID	ZPA train release program ID	ZPA module program ID	No ZPA program ID
Single release 1 zone	Train release 1 zone	ZPA transfer in	I/O device
Single release 2 zone	Train release 2 zone	ZPA transfer out	
Single release 3 zone	Train release 3 zone	ZPA merge	
Single release 4 zone	Train release 4 zone	ZPA HPD	
		HPD semi automatic	
		Transfer semi automatic	

Control Timer

- Timer 1: Single release: Transfer communication time
Train release: Time-delayed start of the RollerDrive
- Timer 2: Internal monitoring of the material to be conveyed
- Timer 3: RollerDrive overrun
- Timer 4: Error reset



The functions and default settings for the timers vary depending on the selected control program (see the description of control programs in the "MultiControl / RollerDrive - Start-up and Programming" supplement).

Press the "Submit" button to transfer the modified parameters to the MultiControl.

Error State

Error State	
Error Info	
State	: Operational
Active Error	: BusComFail (21)
Last Error	: 00:02:29:756 51 DriveError #2

- Display of the current status of the MultiControl
- Display of the current error
- Display of the most recent error

Error Handling Settings

Error Handling Settings	
System Errors	
Network Error	: Warning <input type="checkbox"/>
Over Voltage Error	: Warning <input type="checkbox"/>
Under Voltage Error	: Warning <input type="checkbox"/>
Motor Error	: Warning <input type="checkbox"/>
Generl Control Error	: Ignore <input type="checkbox"/>
Sensor Error	: Ignore <input type="checkbox"/>
Control Errors	
Control Error 1	: Ignore <input type="checkbox"/>
Control Error 2	: Ignore <input type="checkbox"/>
Control Error 3	: Ignore <input type="checkbox"/>
Control Error 4	: Ignore <input type="checkbox"/>
Control Error 5	: Ignore <input type="checkbox"/>
Control Error 6	: Ignore <input type="checkbox"/>
Control Error 7	: Ignore <input type="checkbox"/>
Control Error 8	: Ignore <input type="checkbox"/>
<input type="button" value="Submit"/> <input type="button" value="Reset"/>	

Network error

Monitoring of communication between MultiControl and PLC:

- Ignore: Error is not displayed.
- Warning: Error is indicated by fault LED flashing twice.
The conveying process is not interrupted.
- Immediate stop: Error is indicated by fault LED flashing twice.
The conveying process is interrupted.



If the MultiControl is operated without PLC, we recommend the "Ignore" setting.

If the MultiControl is operated with PLC, we recommend the "Immediate stop" setting.

Over voltage error

Supply voltage too high:

- Ignore: Error is not displayed.
- Warning: Error is indicated by fault LED flashing six times.
The conveying process is not interrupted.
- Immediate stop: Error is indicated by fault LED flashing six times.
The conveying process is interrupted.

Start-up and operation

Under voltage error

Supply voltage too low:

- Ignore: Error is not displayed.
- Warning: Error is indicated by fault LED flashing five times.
The conveying process is not interrupted.
- Immediate stop: Error is indicated by fault LED flashing five times.
The conveying process is interrupted.

Motor error

Monitoring of the motors:

- Ignore: Error is not displayed.
- Warning: Error is indicated by fault LED flashing three times.
The LED goes out when the error is no longer present. Further motors connected to the MultiControl rotate.
- Immediate stop: Error is indicated by fault LED flashing three times.
Further motors connected to the MultiControl stop.

General control error

Monitoring of the control system:

- Ignore: Error is not displayed.



"Immediate stop" and "Normal stop" have the same function.

The control error 1–8 settings have no function.

Press the "Submit" button to transfer the modified parameters to the MultiControl.

Changes only come into effect when the control is switched off/on.

MultiControl Error Log

MultiControl Error Log		
Error Info 0		
Time	Error	Description
00:00:06:823	70	SystemRestart
00:00:06:460	70	SystemRestart
00:00:06:459	70	SystemRestart
00:00:06:790	70	SystemRestart
00:00:06:799	70	SystemRestart
00:00:07:823	22	BusStartUp
00:00:11:131	102	NewStateTable
00:00:11:153	102	NewStateTable
00:00:11:154	50	DriveError #1
00:00:11:154	51	DriveError #2
00:00:11:154	52	DriveError #3
00:00:11:154	53	DriveError #4
00:00:11:161	50	DriveError #1
00:00:11:161	51	DriveError #2

Error log for the most recent errors/messages with time stamp.

For an explanation of error codes, see „Error codes“ on page 62.

Start-up and operation

Teach-in



WARNING

Risk of crushing due to unintentional start-up of the RollerDrive!

- Changes in this menu have direct influence on the connected RollerDrive!
- Before starting motors make sure, ensure that no persons are present in the hazardous areas surrounding the conveyor system!

Teach-in

Teach-in Feature

Please read the manual before trigger any of the options below!

Init
 Start
 Finish
 Abort

SubmitReset

Plug&Play

Plug&Play

Plug and Play Feature

Enabled Submit



The "Teach-in" and "Plug&Play" functions are described in the "MultiControl / RollerDrive - Start-up and Programming" supplement.

CAN Gateway

CAN Gateway

CAN Bus Terminal

Mode	Node ID	SDO Idx	Sub Idx	Length	Data
Read	<input type="text" value="dec num"/>	<input type="text" value="hex num"/>	<input type="text" value="hex num"/>	<input type="text" value="dec num"/>	<input type="text" value="hexabytes, e.g. 0FF640"/>
Write					

Send

Node 0>> Response: Unknown, Error: 0

Only used for service purposes.

Service Change Password

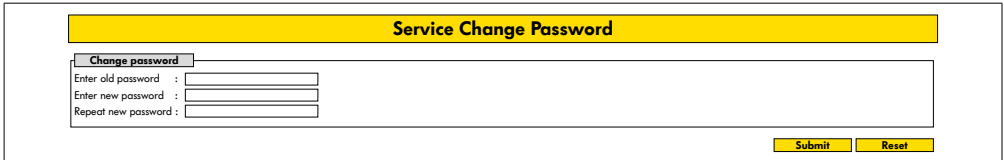

- To change the password, enter the old password followed by the new password twice and transfer this to the MultiControl by pressing the “Submit” button.



- The user name cannot be changed.
- Loading the default settings resets the changed password to the default.

Service Restore Factory Settings

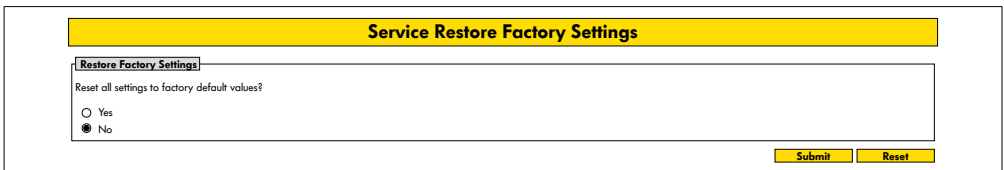

Loading the default settings:

- Select “Yes”
- “Submit” button

NOTE

Irreparable damage to the MultiControl due to premature shutdown of the supply voltage

- Ensure that the power supply is not interrupted until the restart is complete. This process takes approx. two minutes.

Start-up and operation

Service MultiControl Restart

Service MultiControl Restart

MultiControl restart

CAUTION: A restart of MultiControl will stop the control process and interrupt the network connection.

Do you want to restart MultiControl now?

Yes

No

Submit Reset

Restarting the MultiControl:

- Select "Yes"
- "Submit" button



While the MultiControl is being restarted, the existing bus connection to the computer or PLC is interrupted and this must subsequently be restored.

Service Version Information

Service Version Information

Version Info

Hardware Version	: Vx
Hardware Variant	: Bus
Application Software Version	: Vx.x.x.x
System Software Version	: Vx.x.x.x
Network Software Version	: Vx.x.x.x
Serial Number	: 00000093
MAC Address	: 24:0b:b1:20:01:70

Display of the version, serial number and software version of the MultiControl.

Service – Up-/Download

Up- Download

<div style="background-color: #e0e0e0; padding: 2px; margin-bottom: 5px;">Download</div> <p>For download under a different name, please use „Right Click -> Save As...“-option</p> <p>Bus Config : download</p> <p>Application Config : download</p>	<div style="background-color: #e0e0e0; padding: 2px; margin-bottom: 5px;">Upload</div> <p>To make settings effective, please restart module afterwards!</p> <p>Bus Config : upload</p> <p>Application Config : upload</p>
--	--

The MultiControl settings can be downloaded via the user interface and saved to a computer. By storing this data, the settings can be restored when the MultiControl is replaced.

- Right-click on the desired file and select “Save as” to save to the connected PC.



Follow the correct sequence for the upload.

- Bus config
- Application config

NOTE

Irreparable damage to the MultiControl due to premature shutdown of the supply voltage

- Ensure that the power supply is not interrupted during the entire process of changing the bus type until the restart is complete. This process takes approx. two minutes.

Start-up and operation

6.4 Magnetic sensor

The magnetic sensor can be used to perform the following functions:

- Setting the sensors
- Setting the bus type
- Executing the teach-in process
- Switching the LED displays for the sensors / I/Os on or off
- Deactivating Plug&Play
- Resetting the MultiControl to the default settings

A magnet is required in order to operate the magnetic sensor (see „Accessories“ on page 66). The magnetic sensor is located on the top of the MultiControl, between the two Rs of “INTERROLL” directly in front of the base plate (see „Setup“ on page 16).



Further information can be found in the "MultiControl / RollerDrive - Start-up and Programming" supplement.

6.5 Service data objects (SDO)

Virtually all MultiControl settings (except the bus type) can be modified by means of acyclical communication. This communication corresponds to the service data objects (SDO) of the CANopen protocol. They can be accessed via the RDREC and WRREC functions according to IEC 61131-3.



Further information can be found in the "MultiControl / RollerDrive - Start-up and Programming" supplement.

Ethernet/IP, Object Class Adapter = 0x64, Get Attribute Single, Set Attribute Single

Profinet, HW Identification acyclic access point, RDREC, WRREC

6.6 Operation



WARNING

Risk of crushing due to unintentional start-up of the RollerDrive!

- Before switching on the power supply, ensure that no persons are present in the hazardous areas surrounding the conveyor system!
- In ZPA mode, all connected RollerDrives carry out an initialization run for a maximum of four seconds after switching on the supply voltage!



When the MultiControl is functioning as an I/O device, it cannot start or stop motors or carry out other actions independently. To do this, it requires commands from a higher-level control system, e.g. a PLC.

Check before every start-up

- Check all MultiControls for any visible damage.
- Check all protective equipment.
- Ensure that none of the RollerDrives connected to the MultiControl are jammed.
- Specify in detail how the material to be conveyed should be set down on the conveyor and monitor this to ensure it is carried out correctly.



Take the ambient conditions into account during operation (see „Technical Specifications“ on page 19).

Start

- Ensure that the ambient conditions are maintained during operation (see „Technical Specifications“ on page 19).
- Switch on the power supply.
- MultiControl BI: After switching on the motor voltage, wait 30 seconds until all connected RollerDrive are initialized.
- Send the corresponding signal to the MultiControl.

Stop

The conveyor system will stop under the following circumstances:

- When the power supply is switched off
- When no start signal is present
- When an error from a corresponding error class is present (see „Error Handling Settings“ on page 45)

Start-up and operation

6.7 Procedure in the event of accidents or faults

- Stop the conveyor system immediately, switch off the power supply and ensure that it cannot be unintentionally switched on again.
- In the event of an accident: Perform first aid and call for the emergency services.
- Inform the relevant supervisor.
- Have specialist personnel rectify the fault.
- Only resume operating the conveyor system once this has been approved by the specialist personnel.

7 Maintenance and cleaning



CAUTION

Risk of injury from following incorrect procedure.

- Maintenance and repair work must only be carried out by authorised and trained (specialist) personnel.
- Maintenance and repair work must only be carried out when the system has been disconnected from the power supply. Switch off the power to the MultiControl and ensure that it cannot be unintentionally switched on again.
- Put up signs to indicate that maintenance or cleaning work is being carried out.

7.1 Maintenance

Checking the MultiControl

The MultiControl itself requires no maintenance. However, in order to prevent faults from occurring, the connections and fixings must be examined on a regular basis.

- In the course of regular inspection and maintenance work on the conveyor, ensure that the screws of the MultiControl are still tight, that the cables are still arranged correctly and that the corresponding connections are correctly attached.

Replacing the MultiControl

If a MultiControl is damaged or defective, it must be replaced.



Do not attempt to open the MultiControl.

- Install a new MultiControl (see „Decommissioning“ on page 65 and „Assembling the MultiControl“ on page 22).
- Configure the new MultiControl (see „Start-up and operation“ on page 31).

Maintenance and cleaning

7.2 Cleaning

Under humid conditions, dust and dirt can cause a short circuit. Therefore, ensure dirty environments are cleaned regularly to prevent short circuits that could damage the MultiControl.

NOTE

The MultiControl can be damaged if it is not properly cleaned.

- Never immerse the MultiControl in fluids.
- If necessary, vacuum any dust or dust that is present.
- To clean the MultiControl more thoroughly, disconnect it from the power supply, detach it and wipe it with a damp cloth.

8 Assistance in the event of faults

8.1 Understanding the LEDs

LEDs on the MultiControl indicate the operating state of the conveyor.

Status description of the LEDs:

- Off: LED is permanently off
- On: LED is permanently on
- Flashes at 1 Hz: LED flashes at a frequency of 1 Hz; duty ratio 1:1
- Flashes at 2 Hz: LED flashes at a frequency of 2 Hz; duty ratio 1:1
- - : LED status is variable

General LEDs

Power	Ready	Net run	Fault	Meaning	Priority
On	On	On	Off	Ready for operation, no error	
-	On	Flashing 1 Hz	Off	Bus start-up mode: After starting, the system waits 30 s for a connection to be established by the PLC.	
-	-	-	Flashes x1	Error in the application program, e.g. time out	1
-	-	-	Flashes x2	Communication error: Connection not established within 30 s of start-up or connection to PLC lost. Error acknowledges itself automatically.	3
-	-	-	Flashes x3	RollerDrive error: Defective RollerDrive indicated by flashing of the corresponding "RD" LED	2
On	On	-	Flashes x4	No power supply to motors.	5
-	-	-	Flashes x5	Voltage error, undervoltage	4

Assistance in the event of faults

Power	Ready	Net run	Fault	Meaning	Priority
-	-	-	Flashes x6	Voltage error, overvoltage	4
-	-	-	Flashes x7	Temperature in the MultiControl too high.	6
-	-	-	Flashes x8	Overload protection for the brake resistor active.	7
-	-	-	Flashes x9	Handshake communication interrupted. See instructions on ZPA and ZPA+ applications.	
-	-	-	Flashes x10	No connection to the neighbouring devices. See instructions on ZPA and ZPA+ applications.	
-	-	-	Flashes x11	A configured neighbouring device has an error (see ZPA+, "RemoteEmergency" in the error log)	



If several errors occur at the same time, only the error with the highest priority is displayed.

- To eliminate the errors, refer to „Troubleshooting“ on page 59.

Connection LEDs

LED	Status	Meaning
Sensor 1 Sensor 2 Sensor 3 Sensor 4	On	Logical switching status of the displayed sensor: Positive logic configured and logical "1" (PNP 24 V, NPN 0 V) at the input, or negative logic configured and logical "0" at the input
I/O 1 I/O 2 I/O 3 I/O 4	On	Logical switching status of the displayed input/output: Positive logic configured and logical "1" (PNP 24 V, NPN 0 V) at the input, or negative logic configured and logical "0" at the input
RD 1 RD 2 RD 3 RD 4	On	Target value applied to the displayed RollerDrive
Link/act A Link/act B	On or flashing (with EtherCAT bus type)	Displayed network connection is OK

8.2 Troubleshooting

The MultiControl is a complex system. There are many correlations between all participants in the system. In such a system, errors are of course likely to occur, either as a result of the conveying processes or the interaction between the individual components. Not all errors can be displayed in detail and it is not always possible to make a correlation between the error location and the place at which it is displayed. More detailed error diagnosis is possible via the PLC.

If you are not able to successfully troubleshoot the problem or eliminate the error, contact Interroll Support and have the following information to hand:

- Serial number of the affected MultiControl
- Information about the configuration
- Information about the LED displays
- Information about the error codes

Assistance in the event of faults

Fault	Possible cause	Remedy
Communication error	Connection to PLC interrupted	<ul style="list-style-type: none">➤ Check the bus wiring➤ Check the bus type➤ Check the network address and bus name
RollerDrive error	Error signal from the RollerDrive or RollerDrive not connected to the activated motor output	<ul style="list-style-type: none">➤ Check the motor configuration➤ Ensure that all RollerDrives are connected correctly➤ Check for faults in accordance with the RollerDrive operating manual
No power supply to motors		<ul style="list-style-type: none">➤ Check the power supply (emergency stop?)
The MultiControl is not working or not working properly	No or insufficient power supply	<ul style="list-style-type: none">➤ Ensure that the power supply is within the specified voltage range➤ Check the connections and correct them if necessary
The MultiControl is defective or damaged	Internal fuse has been triggered or is defective	<ul style="list-style-type: none">➤ Replace the MultiControl

Assistance in the event of faults

Fault	Possible cause	Remedy
RollerDrive does not rotate	RollerDrive not or not correctly connected or RollerDrive defective	<ul style="list-style-type: none">➤ Ensure that the power supply is within the specified voltage range➤ Check the connections and correct them if necessary➤ Replace the RollerDrive if necessary
	Brake resistor overheating: The application is recovering too much energy or the power supply is too high	<ul style="list-style-type: none">➤ Allow the system to cool down➤ If necessary, reduce the ambient temperature➤ Ensure that the power supply is within the specified voltage range

Assistance in the event of faults

Error codes

No.	Short text	Comments
0	ApplErrorNone	No error in the application program
1	ApplErrUnk	Unknown error in the application program
2	ApplErrSystemSevere	Severe system error
3	ApplErrSystemMinor	Minor system error
4	ApplErrSystemWarning	Warning
5	PllErrItemNotFound	Searched for object not found
6	ApplErrRange	Number outside the valid value range
10	ApplErrNoTerminlInput	Terminal has no input data
11	ApplErrStopByOperator	Terminal session aborted
12	ApplErrParamlll	Invalid parameter or input value
13	ApplErrModuleInit	Initialisation error in the module
14	ApplErrBufferOverflow	Buffer overflow
20	ApplErrInvalidBusConf	Invalid network or bus configuration
21	ApplErrBusCom	Network communication error
22	ApplErrBusStartUp	Network restart after system (re)start
23	ApplErrNbrMsgRegister	Message received from neighbouring device
24	ApplErrNbrMsgReceive	Error in communication with neighbouring device: Reception interrupted
25	ApplErrNbrMsgTransmit	Error in communication with neighbouring device: Transmission interrupted
26	ApplErrNbrMsgInvalid	Error in communication with neighbouring device: Invalid message received
27	ApplErrNbrHandShake	Error in communication with neighbouring device: No response to handshake message received
28	ApplErrNbrLifeCheck	Error in communication with neighbouring device: No life signal received from neighbouring device
29	ApplErrNbrEmergency	Error in communication with neighbouring device: No response to emergency stop message
30	ApplErrErrorDataUpdate	Access error to error data

Assistance in the event of faults

No.	Short text	Comments
31	ApplErrErrorLogUpdate	Access error to error log file
40	ApplErrPanelMode	Change of mode not permitted
41	ApplErrPanelLedBlocked	Access to LED control not permitted
42	ApplErrInvalidAppConf	Invalid configuration of the application program
50	ApplErrDriveError1	RollerDrive 1 error
51	ApplErrDriveError2	RollerDrive 2 error
52	ApplErrDriveError3	RollerDrive 3 error
53	ApplErrDriveError4	RollerDrive 4 error
60	ApplErrStateTable	Error in the application program
61	ApplErrCtrlError1	Specific errors in the application program. Errors in the ZPA/ZPA+ programs are explained in the "MultiControl / RollerDrive - Start-up and Programming" supplement.
62	ApplErrCtrlError2	
63	ApplErrCtrlError3	
64	ApplErrCtrlError4	
65	ApplErrCtrlError5	
66	ApplErrCtrlError6	
67	ApplErrCtrlError7	
68	ApplErrCtrlError8	
69	ApplErrStartProgram	Application program cannot be started
70	ApplErrSysRestart	(Re)start of the application program/system
71	ApplErrPowerFail	Voltage error: Supply voltage failure
90	ApplErrTemperature	Temperature error: Temperature at the brake resistor too high
91	ApplErrLowVoltage	Voltage error: Supply voltage (L2) too low
92	ApplErrHighVoltage	Voltage error: Supply voltage (L2) too high

Assistance in the event of faults

No.	Short text	Comments
93	ApplErrMotorVoltage	Voltage error: No motor voltage
94	ApplErrOvcOverloaded	Brake resistor overload
95	ApplErrRemoteEmergency	Emergency stop from neighbouring transfer device
96	ApplErrLogVoltLow	Voltage error: Supply voltage (L1) too low
97	ApplErrLogVoltHigh	Voltage error: Supply voltage (L1) too high
101	ApplErrInvalidStateTblConf	Error when loading the application program
102	ApplErrNewStateTable	New application program loaded
103	ApplErrInvalidErrConf	Invalid configuration for the selected application program
104	ApplErrInvalidTeachParams	Invalid parameters for teach-in procedure
105	ApplErrPapSaveConfig	Not possible to save connection settings for communication with neighbouring devices
106	ApplErrPapReadConfig	Not possible to read connection settings for communication with neighbouring devices

9 Decommissioning and disposal



CAUTION

Risk of injury from following incorrect procedure.

- Decommissioning must only be carried out by authorised, qualified personnel.
- Only decommission the MultiControl when the system has been disconnected from the power supply.
- Switch off the power to the MultiControl and ensure that it cannot be unintentionally switched on again.

9.1 Decommissioning

- Remove all cables from the MultiControl.
- Loosen the screws that have been used to attach the MultiControl to the base plate and remove the MultiControl.
- If the MultiControl is to be completely dismantled, also loosen the screws that have been used to attach the base plate to the conveyor frame and remove the base plate from the conveyor frame.

9.2 Disposal



In principle, the operator is responsible for the professional and environmentally friendly disposal of the products.

The implementation of the WEEE Directive 2012/19/EU in national laws must be observed.

Alternatively, Interroll offers to take back the products.

Contact:

atse.customerservice@interroll.com

Appendix

10 Appendix

10.1 Accessories

Article	Article number
Ribbon cable distributor	S-1115717
Ribbon cable for power supply (25 m)	S-1004030
High Performance power supply unit HP 5424	S-1113899
High Performance power supply unit HP 5448	S-1113900
Magnetic key	S-64100210
MultiControl Y-cable	S-1104460
MultiControl communication cable (3 m)	S-1104438
MultiControl dummy plugs	S-1104466
Pack: 3 x RollerDrive M8, plug-in 3 x sensor M8, screw-in 1 x communication M12, screw-in	
RollerDrive EC310 extension cable (2 m)	S-1004033
RollerDrive EC5000 extension cable (2 m)	S-1113897
Cable bridge for ribbon cable	S-1004028
Cable bridge for shielding	S-1113876

10.2 Translation of the original Declaration of Conformity

EU Declaration of Conformity

EMC Directive 2014/30/EU

RoHS Directive 2011/65/EU

The manufacturer

Interroll Software & Electronics GmbH
Im Südpark 183
4030 Linz
AUSTRIA

hereby declares that the

- **Interroll MultiControl AI – model number 1103563**
- **Interroll MultiControl BI – model number 1103564**

conform to the applicable provisions and the associated CE marking in accordance with the aforementioned Directives.

List of the coordinated standards that have been applied:

EN 61326-1:2013
EN 61000-3-2:2014
EN 61000-3-3:2013
EN IEC 63000:2018

Authorised for compiling technical documentation:

Interroll Software & Electronics GmbH, Im Südpark 183, 4030 Linz



Andreas Eglseer
Managing Director, Interroll Software & Electronics GmbH
Linz, 01.07.2022

Appendix

10.3 UKCA Declaration of Conformity

Declaration of conformity

UK Electromagnetic Compatibility Regulations 2016

UK Restriction of the Use of Certain Hazardous Substances in
Electrical and Electronic Equipment Regulations 2012

The manufacturer

Interroll Software & Electronics GmbH
Im Südpark 183
4030 Linz
AUSTRIA

hereby declares that the

- **Interroll MultiControl AI – model number 1103563**
- **Interroll MultiControl BI – model number 1103564**

**conform to the applicable provisions and the associated UKCA marking
in accordance with the aforementioned Directives.**

Authorised for compiling technical documentation:
Interroll Software & Electronics GmbH, Im Südpark 183, 4030 Linz



Andreas Eglseer
Managing Director, Interroll Software & Electronics GmbH
Linz, 01.07.2022

INSPIRED BY EFFICIENCY

EN | 07/2022 | Version 3.1