

HELICAL MODULAR CHUTE



24V

48V

400V

Product description

The Helical Modular Chute (HMC) provides a simple and easy solution for vertical transport in confined spaces. With a durable and robust steel construction, this product serves a wide range of material handling applications: Retail & E-commerce, warehousing & distribution as well as courier, express & parcel.

Scope of delivery

- Chute delivered un-assembled
- Supports for entry & exit slides not provided

Benefits

- Minimal cost of ownership
- Maintenance free
- Individually adjustable stair-step panels
- Full gravity solution – no power required
- Small footprint
- Very long service life



HELICAL MODULAR CHUTE TECHNICAL DATA

Technical data

Maximum loading	50 kg/m (34 lb/ft)
Entry slide width	2.5 m max.
Exit slide width	as required
Angles of decline	16° or 26°
Arc angle range (90° increments)	90° - 1800°

Materials

- Stainless steel stair-steps
- Mild steel side guides, support arms, brackets & center pole
- Mild steel parts will be painted with RAL number of customer's choosing
 - Standard RAL 9005 – Jet Black
- Low friction UHMW available upon request

Dimensions

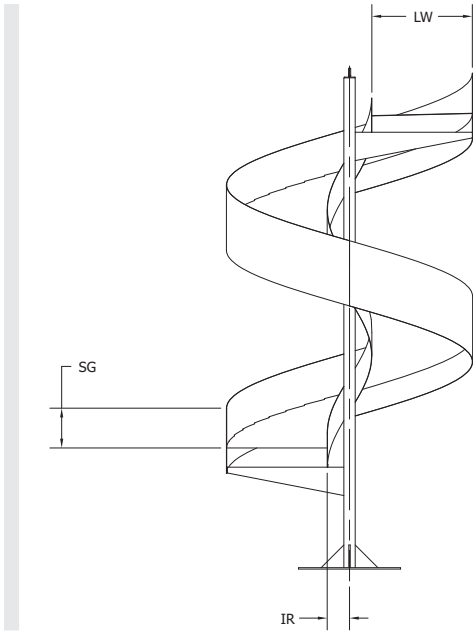

LW	Lane width	700, 900, 1100, 1250 mm
IR	Inside radius	200 mm
SG	Outer side guide height	300 – 600 mm

Options

- Slides for multiple entry points available upon request
- Entry & exit slides – recommended for smooth transitions