

# CATALOG

## DRUM MOTORS

### DL SERIES

### DM SERIES

### DP SERIES

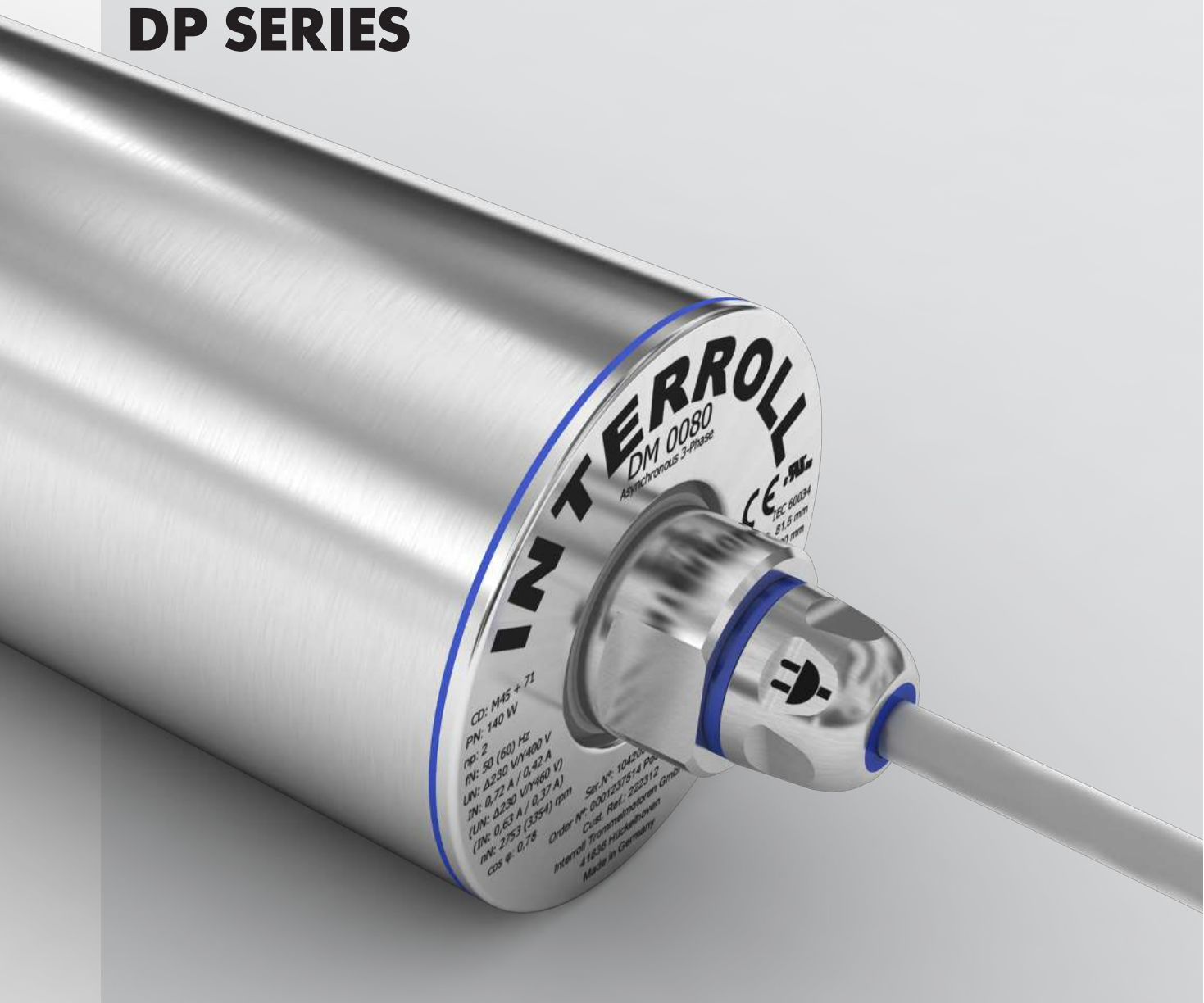

**INTERROLL**  
DM 0080  
Asynchronous 3-Phase  
CE  
IEC 60034  
81.5 mm  
17 mm

CD: M45 + 71  
PN: 140 W  
np: 2  
Rn: 50 (60) Hz  
UN: Δ230 V/√400 V  
IN: 0.72 A / 0.42 A  
(UN: Δ230 V/√460 V)  
(IN: 0.63 A / 0.37 A)  
nN: 2753 (3354) rpm  
cos φ: 0.78

Order No.: 10420  
Interroll Transmissions GmbH  
41636 Hückelhoven  
Made in Germany

# PRODUCT OVERVIEW

	DM 0080	DM 0080	DM 0080	DM 0080	DM 0080	DM 0113	DM 0113	DM 0113	DM 0138	DM 0138	DM 0165	DM 0217
<b>Motor technology</b>	Asynchronous	Asynchronous	Asynchronous	Asynchronous	Synchronous	Asynchronous	Asynchronous	Synchronous	Asynchronous	Synchronous	Asynchronous	Asynchronous
No. phase	3-phase	3-phase	1-phase	1-phase		3-phase	1-phase		3-phase		3-phase	3-phase
Diameter	81.5 mm	81.5 mm	81.5 mm	81.5 mm	81.5 mm	113.5 mm	113.5 mm	113.5 mm	138 mm	138 mm	164 mm	217.5 mm
Gear material	Steel	Technopolymer	Steel	Technopolymer	Steel	Steel	Steel	Steel	Steel	Steel	Steel	Steel
Rated power	40 – 140 W	40 – 75 W	25 – 110 W	25 – 110 W	145 – 550 W	160 – 550 W	250 W	300 – 1100 W	160 – 1000 W	1800 W	370 – 2200 W	370 – 3000 W
Rated torque	1.2 – 59.8 Nm	3.2 – 20.3 Nm	0.8 – 39.2 Nm	4.5 – 21.4 Nm	2.1 – 65 Nm	6.7 – 157 Nm	19.1 – 71.5 Nm	5.4 – 126.8 Nm	15.7 – 238.3 Nm	32.7 – 155.1 Nm	32.1 – 365.2 Nm	34.2 – 533.6 Nm
Max. belt pull	1467 N	498 N	961 N	525 N	1594 N	2767 N	1260 N	2234 N	3454 N	2248 N	4453 N	4907 N
Speed of the shell	0.03 – 2.5 m/s	0.07 – 0.87 m/s	0.05 – 2.49 m/s	0.05 – 0.9 m/s	0.08 – 2.72 m/s	0.05 – 1.86 m/s	0.18 – 0.67 m/s	0.15 – 2.97 m/s	0.04 – 2.29 m/s	0.72 – 2.41 m/s	0.08 – 2.53 m/s	0.126 – 3.357 m/s
Drum width (FW)	200 – 1200 mm	239 – 1200 mm	250 – 1200 mm	287 – 1200 mm	192 – 1200 mm	257 – 1400 mm	307 – 1400 mm	208 – 1400 mm	307 – 1600 mm	357 – 1600 mm	407 – 1750 mm	407 – 1750 mm
Friction-driven belt	●	●	●	●	●	●	●	●	●	●	●	●
Positive driven belt	●	●	●	●	●	●	●	●	●	●	●	●
Without belt	●	–	–	–	●	●	–	●	●	●	●	●

	DL 0080	DL 0080	DL 0113	DL 0113
<b>Motor technology</b>	Asynchronous	Asynchronous	Asynchronous	Asynchronous
No. phase	3-phase	1-phase	3-phase	1-phase
Diameter	81.5 mm	81.5 mm	113.3 mm	113.3 mm
Gear material	Technopolymer	Technopolymer	Technopolymer	Technopolymer
Rated power	40 – 85 W	25 – 110 W	70 – 370 W	58 – 306 W
Rated torque	3.4 – 20.6 Nm	4.5 – 21.4 Nm	8.1 – 85.1 Nm	7.4 – 72.9 Nm
Max. belt pull	505 N	525 N	1500 N	1302 N
Speed of the shell	0.072 – 0.91 m/s	0.049 – 0.90 m/s	0.048 – 1.51 m/s	0.048 – 1.52 m/s
Drum width (FW)	270 – 962 mm	270 – 962 mm	262 – 1112 mm	262 – 1112 mm
Friction-driven belt	●	●	●	●
Positive driven belt	–	–	–	–
Without belt	–	–	–	–

	DP 0080	DP 0089
<b>Motor technology</b>	Asynchronous	Asynchronous
No. phase	3-phase	3-phase
Diameter	80 mm	89 mm
Gear material	Steel	Steel
Rated power	70 W	70 W
Rated torque	22 Nm	22 Nm
Max. load in kg	1250 kg	1250 kg
Speed of the shell	0.2 m/s	0.22 m/s
Installation length (EL)	500 – 1500 mm	500 – 1500 mm
Friction-driven belt	–	–
Form-fit drive head	●	●
Without belt	●	●

---

## Symbols



Drum motor



Idler pulley



Options



Accessories

## Contents

The Interroll Group	4
The highly efficient belt drive	6
Interroll platform for drum motors	7
DL series	8
DL 0080	8
DL 0113	18
Lagging and coating	28
Cable overview and connection diagrams	31
Options and accessories	36
DM series	44
DM 0080	44
DM 0113	62
DM 0138	76
DM 0165	86
DM 0217	98
Lagging and coating	108
Cable overview and connection diagrams	122
Options and accessories	134
DP series	164
Pallet Drive 0080 / 0089	164
Cable overview and connection diagrams	167
Options and accessories	169
Application notes	172



[www.interroll.com](http://www.interroll.com)

# THE INTERROLL GROUP

---

The Interroll Group is a globally leading supplier of high-quality key products and services for internal logistics. The company, which is listed on the stock exchange and has its headquarters in Switzerland, employs some 2300 people (in 2020) in 34 companies (in 2020) around the globe.

The solutions for our customers' daily logistical challenges are based on Interroll key products that are built on a worldwide common platform.



## Conveyor Rollers

Interroll is the worldwide leading provider of conveyor rollers that can be found in a multitude of applications in internal logistics. For the roller production, we merge quality, flexibility and speed. More than 13 million rollers in 60,000 variants leave our plants worldwide every year. Our production is always order-driven, even for the smallest order quantities and, if desired, even with a delivery time of 24 hours. Proven.



## Drives and Controls

Interroll is a leading manufacturer in the segment of DC motor rollers and drum motors.

Interroll RollerDrive and their controls are used in automated conveyor technology. Energy-efficient DC drives are installed in decentralized conveyor systems and, as a result, optimize energy demand and material handling. The bus interface enables integrating the zero pressure accumulation conveyor technology into Industry 4.0 systems.

Interroll Drum Motors are designed for use in belt conveyors and conveyor systems. These robust, high-quality belt drives enable the construction of maintenance-free, energy-efficient conveyor belt systems for the majority of industrial applications as well as for food processing, baggage handling and supermarket checkouts.



## Conveyors & Sorters

The Modular Conveyor Platform (MCP) from Interroll offers highest flexibility: a broad spectrum of modules, consisting of roller conveyors, belt conveyors as well as key products such as transfer, high-performance diverts or spiral lifts, covers all requirements of the material handling.

The Interroll Crossbelt Sorters were developed with an eye on precision for fast and precise sorting of goods of all types from 50 g to 35 kg. More than 400 Interroll sorters are used every day by the largest CEP players and E-commerce enterprises worldwide.

The brand-new modular pallet conveyor platform (MPP) offers roller and chain conveyors as well as special conveyors such as transfers and turntables to create a fully integrated, robust, space-saving and energy-saving solution for high throughput handling of pallets.

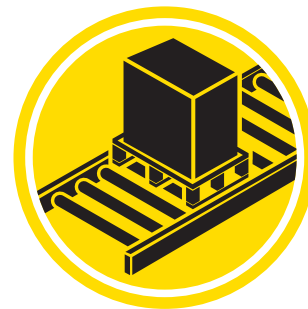

## Pallet & Carton Flow

Interroll Pallet Flow and Carton Flow are the first choice when it comes to rapid turnarounds and optimizing the storage and commissioning process. Thanks to its efficiency and robustness, Pallet Flow ensures long-term availability and more flexibility for peaks in orders. The compact design reduces space requirements by up to 50 percent compared to conventional solutions. The integrated TimePlus Separator as well as the Magnetic Speed Controller increase the safety of the work environment and significantly reduce the risk of damages to goods.

The Interroll Carton Flow solutions are efficient as well as ergonomic, and were developed to improve the commissioning output.

# THE HIGHLY EFFICIENT BELT DRIVE



## Compact, robust and absolutely hygienic

Since the drum motor is installed directly in the frame of the conveyor belt in a space-saving way, the transport capacity is maximized given the same base area. Positive side effect: Elegantly designed conveyor belts with evenly distributed weights. The installation or replacement of a drum motor is generally simple and quick using the plug-and-play principle, because only a few components have to be installed - thus saving time and money. In food processing, perfect hygiene and good cleaning options are especially important: This is where the drum motor scores big with its encapsulated design made of stainless steel.



## Proven principle, efficient drive

In principle, drum motors are energy-efficient because they directly drive the conveyor belt. In addition, they are practically maintenance-free and extremely wear-resistant, thereby significantly reducing the operating costs of the conveyor system and the risk of standstills or breakdowns. By the way: High-quality sealing systems ensure that a drum motor will also run reliably in aggressive environments.

The Interroll synchronous drum motors have a very low power loss of only 9 %. The planetary gear box made of steel transfers 92 – 95 % of the power directly to the conveyor. They are especially suited to applications where a high-torque, dynamic drive, a wide speed range, or high duty cycles are necessary.



## All-rounder with a broad application range

Drum motor applications are varied: When used in friction-driven belts, the motor is cooled directly via the belt tensioned over the drum shell. Modular plastic belts are not tensioned; in this case, the drive is form-fit via sprockets or a profile lagging. Solid homogeneous belts are also positive driven, whereby a profile on the underside of the belt engages in a drum profile made of hygienically certified PU. But it also works entirely without a belt and the drum motor transports the material directly.



## Practice-oriented, scalable, and thought out in detail

The new drum motor platform from Interroll combines the different motor concepts in a single design and makes it easy for customers to build their own, completely individual conveyor system. Since all motors have the same shafts, the number of different parts from the original equipment manufacturer is reduced and conveyor construction is significantly easier. The broad speed spectrum covers all imaginable applications. The clever plug-and-play solution makes installation easier. Each motor is approved, tested, and modularized so that it can be produced and delivered around the world in the shortest amount of time. Also available as oil-free variants!

## Flexibility and robustness make the difference



### More performance, more configurability

The broad range of services for the motors covers all conceivable uses in the food industry, intralogistics and manufacturing. All motors are optimized for their application, giving planning personnel the freedom to choose between synchronous and asynchronous designs.



### More hygienic

All Interroll Drum Motors of the new generation meet the highest standards of hygiene according to IP69k. This gives users the assurance that the cleaning process meets the highest standard.



### Lower costs, more service

The clever plug-and-play wiring solution and simple installation, assembly and maintenance ensure noticeable savings in time and costs, as well as reduced downtimes of the conveyor system. Replacement parts available worldwide through Interroll and service partners make repairs easy and offer a faster, better service.



### RFID Chip

At Interroll we constantly strive to improve our solutions to help you stay on top of your game. Digitalization and connected products are the way forward in material handling. That's why we integrated an RFID chip in our Drum Motors. This will allow you to identify the specific type of drive and its features, making your life a lot easier when it comes to fine-tuning your system, as well as maintenance and spare parts management. No more time wasted in finding serial numbers, digging up documentation and sending emails to ask for specs. You'll have all the info you need at your fingertips with one single scan.



### Tested quality, innovative technology

All motor components are standardized, tested, and approved in elaborate testing. Modularized motor types have been developed for all current applications; they are quickly available and contribute to minimizing costs.



### Fewer breakdowns

A stable planetary gear train is enough for a high torque in all motors, holds up against bending, and resists overloads and impact loads. The result is safer, more reliable operation.



### More stability

The strong 30 mm shaft and the larger ball bearings on Interroll's new drum motors allow significantly higher belt tensions. It provides a safety net even in cases of a defective belt tracking or overtensioned conveyor belts.







## Technical data

	<b>Asynchronous squirrel cage motor, IEC 34 (VDE 0530)</b>
<b>Insulation class of motor windings</b>	Class F, IEC 34 (VDE 0530)
<b>Voltage</b>	230/400 V $\pm 5\%$ (IEC 34/38)
<b>Frequency</b>	50 Hz
<b>Shaft seal, internal</b>	NBR
<b>Shaft seal, external</b>	Deflection seal, NBR
<b>Protection rate Motor*</b>	IP66 (with grease nipple)
<b>Thermal controller</b>	Bi-metal switch
<b>Operating mode</b>	S1
<b>Ambient temperature, 3-phase motor</b>	+5 to +40 °C Low temperature ranges on request
<b>Ambient temperature, 1-phase motor</b>	+5 to +40 °C

\* The protection rate of the cable connector may deviate.

## Design variants and accessories

<b>Lagging</b>	Lagging for friction drive belts
<b>Oils</b>	Food-grade oils (EU, FDA)
<b>Certificate</b>	cULus safety certificates
<b>Accessories</b>	Idler pulleys; conveyor rollers; mounting brackets; cables; inverters
<b>Options</b>	Static balancing

# DRUM MOTOR

## DL SERIES

### DL 0080

#### Material variants

The following components can be selected for the drum motor and the electrical connection. The combination of components depends on the material used.

Component	Version	Aluminum	Mild steel	Stainless steel	Brass/nickel	Technopolymer
<b>Shell</b>	Crowned		●	●		
	Cylindrical		●	●		
<b>End housing</b>	Standard	●		●		
<b>Shaft cap</b>	Standard	●				
	With cable protection	●				
	Regreasable			●		
<b>Gear boxes</b>	Planetary gear box					●
<b>Electrical connector</b>	Straight connector			●	●	
	Elbow connector			●		
	Terminal box	●		●		
<b>Motor winding</b>	Asynchronous motor					
<b>External seal</b>	NBR					

# DRUM MOTOR DL SERIES DL 0080

## Motor variants

### Mechanical data for 3-phase asynchronous motor with technopolymer gear

$P_N$ [W]	$n_p$	gs	i	v [m/s]	$n_A$ [min <sup>-1</sup> ]	$M_A$ [Nm]	$F_N$ [N]	$FW_{MIN}$ [mm]	$SL_{MIN}$ [mm]
40	4	3	78.55	0.072	16.8	19.5	479	305	295
40	4	3	71.56	0.079	18.4	17.8	437	305	295
40	4	3	63.51	0.089	20.8	15.8	387	305	295
50	2	3	115.2	0.102	23.9	16.8	412	280	270
60	4	2	19.2	0.293	68.8	7.5	183	305	295
60	4	2	16	0.352	82.5	6.2	152	305	295
60	4	2	13.09	0.43	100.8	5.1	125	305	295
75	2	3	96	0.125	29.4	20.6	505	280	270
85	2	3	78.55	0.152	35.6	19.5	479	280	270
85	2	3	71.56	0.167	39.1	17.8	437	280	270
85	2	3	63.51	0.188	44.1	15.8	387	280	270
85	2	3	52.92	0.226	52.9	13.2	323	280	270
85	2	3	48.79	0.245	57.4	12.1	298	280	270
85	2	3	43.3	0.276	64.7	10.8	264	280	270
85	2	2	19.2	0.622	145.8	5	123	280	270
85	2	2	16	0.747	175	4.2	103	280	270
85	2	2	13.09	0.913	213.9	3.4	84	280	270

$P_N$  = Rated power  
 $n_p$  = Number of poles  
 gs = Gear stages  
 i = Speed ratio  
 v = Speed

$n_A$  = Shell rated speed  
 $M_A$  = Drum motor rated torque  
 $F_N$  = Drum motor rated belt pull  
 $FW_{MIN}$  = Minimum drum width  
 $SL_{MIN}$  = Minimum shell length

# DRUM MOTOR

## DL SERIES

### DL 0080

#### Electrical data for 3-phase asynchronous motor

$P_N$ [W]	$n_p$	$n_N$ [min <sup>-1</sup> ]	$f_N$ [Hz]	$U_N$ [V]	$I_N$ [A]	$\cos\varphi$	$\eta$	$J_R$ [kgcm <sup>2</sup> ]	$I_s/I_N$	$M_s/M_N$	$M_B/M_N$	$M_P/M_N$	$M_N$ [Nm]	$R_M$ [Ω]	$U_{SH\Delta}$ [V]	$U_{SHY}$ [V]
40	4	1320	50	230	0.71	0.65	0.21	1	1.77	1.6	1.6	1.6	0.29	156.5	36	–
40	4	1320	50	400	0.43	0.65	0.21	1	1.77	1.6	1.6	1.6	0.29	156.5	–	66
50	2	2750	50	230	0.46	0.57	0.47	1	4.58	3.82	3.82	3.82	0.17	111.3	15	–
50	2	2750	50	400	0.22	0.71	0.45	1	4.35	2.35	2.35	2.35	0.17	171	–	40
60	4	1320	50	230	0.79	0.65	0.29	1	1.77	1.6	1.6	1.6	0.43	156.5	40	–
60	4	1320	50	400	0.46	0.65	0.29	1	1.77	1.6	1.6	1.6	0.43	156.5	–	70
75	2	2820	50	230	0.51	0.69	0.53	1	4.58	2.5	2.5	2.5	0.25	111.3	20	–
75	2	2820	50	400	0.3	0.7	0.51	1	4.46	2.5	2.5	2.5	0.25	113	–	36
85	2	2800	50	230	0.53	0.73	0.55	1	4.58	2.24	2.24	2.24	0.29	111.3	22	–
85	2	2800	50	400	0.32	0.74	0.52	1	4.46	2.24	2.24	2.24	0.29	113	–	40

$P_N$	= Rated power	$I_s/I_N$	= Ratio of startup current – rated current
$n_p$	= Number of poles	$M_s/M_N$	= Ratio of startup torque – rated torque
$n_N$	= Rated speed of rotor	$M_B/M_N$	= Ratio of pull-out torque – rated torque
$f_N$	= Rated frequency	$M_P/M_N$	= Ratio of pull-up torque – rated torque
$U_N$	= Rated voltage	$M_N$	= Rated torque of rotor
$I_N$	= Rated current	$R_M$	= Branch resistance
$\cos\varphi$	= Power factor	$U_{SH\Delta}$	= Heater voltage in delta connection
$\eta$	= Efficiency	$U_{SHY}$	= Heater voltage in star connection
$J_R$	= Rotor moment of inertia		

# DRUM MOTOR DL SERIES DL 0080

## Mechanical data for 1-phase asynchronous motor with technopolymer gear

$P_N$ [W]	$n_p$	gs	i	v [m/s]	$n_A$ [1/min]	$M_A$ [Nm]	$F_N$ [N]	$FW_{MIN}$ [mm]	$SL_{MIN}$ [mm]
25	4	3	115.2	0.049	11.5	17.8	436	295	285
25	4	3	96	0.059	13.8	14.8	364	295	285
25	4	3	78.55	0.072	16.8	12.1	297	295	285
25	4	3	71.56	0.079	18.4	11	271	295	285
75	2	3	96	0.122	28.6	21.4	525	280	270
75	2	3	78.55	0.149	35	17.5	430	280	270
75	2	3	71.56	0.164	38.4	16	391	280	270
75	2	3	63.51	0.185	43.3	14.2	347	280	270
85	2	3	78.55	0.149	35	20.2	496	295	285
85	2	3	71.56	0.164	38.4	18.4	452	295	285
85	2	3	63.51	0.185	43.3	16.3	401	295	285
110	2	3	63.51	0.185	43.3	20.7	508	295	285
110	2	3	52.92	0.222	52	17.2	423	295	285
110	2	3	48.79	0.241	56.4	15.9	390	295	285
110	2	3	43.3	0.271	63.5	14.1	346	295	285
110	2	2	19.2	0.611	143.2	6.6	162	295	285
110	2	2	16	0.733	171.9	5.5	135	295	285
110	2	2	13.09	0.896	210.1	4.5	110	295	285

$P_N$  = Rated power  
 $n_p$  = Number of poles  
 gs = Gear stages  
 i = Speed ratio  
 v = Speed  
 $n_A$  = Shell rated speed

$M_A$  = Drum motor rated torque  
 $F_N$  = Drum motor rated belt pull  
 $M_{MAX}/M_A$  = Ratio of max. acceleration torque to rated torque  
 $FW_{MIN}$  = Minimum drum width  
 $SL_{MIN}$  = Minimum shell length

# DRUM MOTOR

## DL SERIES

### DL 0080

#### Electrical data for 1-phase asynchronous motor

$P_N$ [W]	$n_p$	$n_N$ [min <sup>-1</sup> ]	$f_N$ [Hz]	$U_N$ [V]	$I_N$ [A]	$\cos\varphi$	$\eta$	$J_R$ [kgcm <sup>2</sup> ]	$I_s/I_N$	$M_s/M_N$	$M_B/M_N$	$M_P/M_N$	$M_N$ [Nm]	$R_M$ [Ω]	$U_{SH \sim}$ [V DC]	$C_R$ [μF]
25	4	1320	50	230	0.39	1	0.28	1.3	2.19	1.11	1.37	1.11	0.18	150	44	3
50	2	2750	50	230	0.54	1	0.4	0.9	3.08	0.94	1.71	0.94	0.17	82	33	3
75	2	2750	50	230	0.68	1	0.48	1	3.19	0.74	1.37	0.74	0.26	66	34	4
85	2	2750	50	230	0.73	0.98	0.53	1.3	5.24	0.93	1.6	0.93	0.3	52	28	6
110	2	2750	50	230	0.94	1	0.51	1.3	1.97	0.73	1.15	0.73	0.38	51	36	8

$P_N$	= Rated power	$I_s/I_N$	= Ratio of startup current – rated current
$n_p$	= Number of poles	$M_s/M_N$	= Ratio of startup torque – rated torque
$n_N$	= Rated speed of rotor	$M_B/M_N$	= Ratio of pull-out torque – rated torque
$f_N$	= Rated frequency	$M_P/M_N$	= Ratio of pull-up torque – rated torque
$U_N$	= Rated voltage	$M_N$	= Rated torque of rotor
$I_N$	= Rated current	$R_M$	= Branch resistance
$\cos\varphi$	= Power factor	$U_{SH \sim}$	= Heater voltage for DC units
$\eta$	= Efficiency	$C_R$	= Capacitor size
$J_R$	= Rotor moment of inertia		

## Belt tension diagrams

### Belt tension depending on drum width

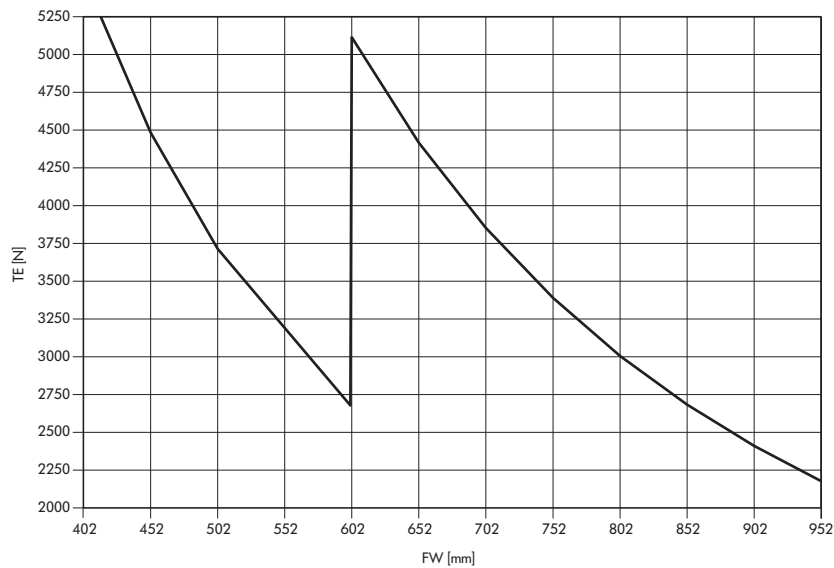

### Belt tension depending on rated speed of shell

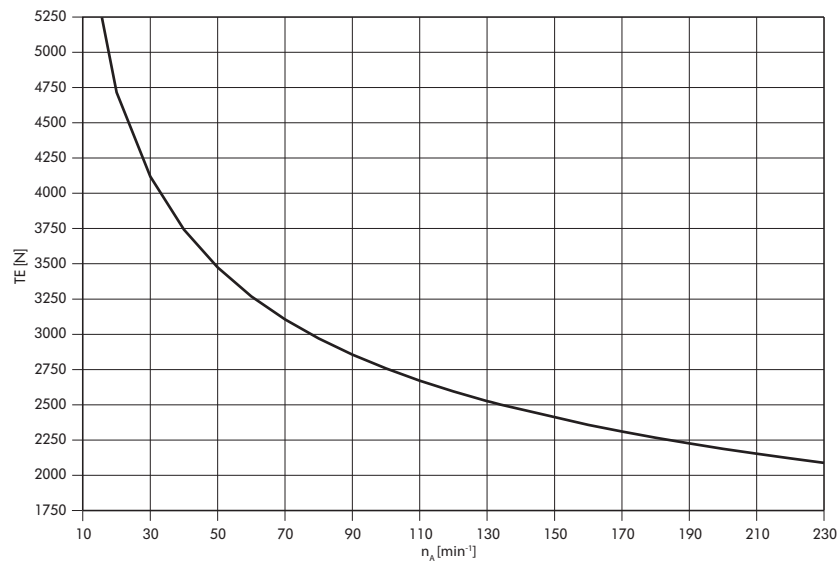

**Note:** The correct value for the maximum permissible belt tension is determined from the speed of the drum motor. When selecting the motor, also check whether the maximum permissible TE value fits the desired drum width (FW).

- TE = Belt tension
- $n_A$  = Shell rated speed
- FW = Drum width

# DRUM MOTOR

## DL SERIES

### DL 0080

#### Dimensions

#### Drum motor

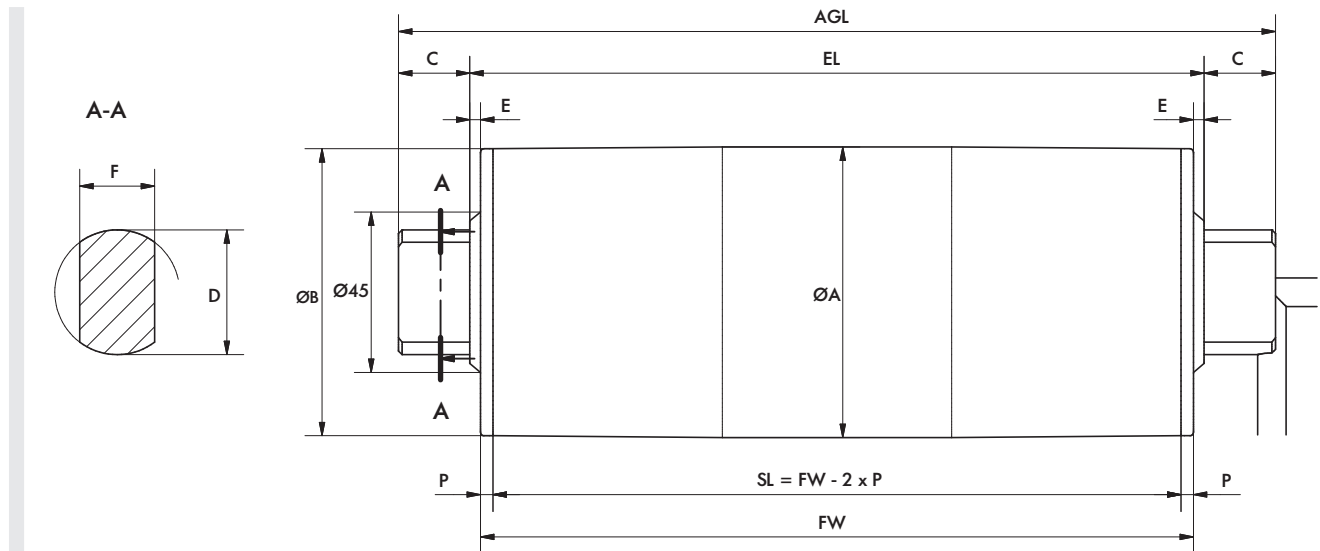

Type	A [mm]	B [mm]	C [mm]	D [mm]	S [mm]	F [mm]	P [mm]	SL [mm]	EL [mm]	AGL [mm]
<b>DL 0080 crowned</b> Shell length SL 260 – 602 mm	81.5	80.0	20	35	3	21	5	FW – 10	FW + 6	FW + 46
<b>DL 0080 crowned</b> Mild steel shell, shell length SL 603 – 952 mm	82.7	81.0	20	35	3	21	5	FW – 10	FW + 6	FW + 46
<b>DL 0080 crowned</b> Stainless steel shell, shell length SL 603 – 952 mm	83.0	80.0	20	35	3	21	5	FW – 10	FW + 6	FW + 46
<b>DL 0080 cylindrical</b> Shell length SL 260 – 602 mm	80.5	80.5	20	35	3	21	5	FW – 10	FW + 6	FW + 46
<b>DL 0080 cylindrical</b> Mild steel shell, shell length SL 603 – 952 mm	82.7	82.7	20	35	3	21	5	FW – 10	FW + 6	FW + 46
<b>DL 0080 cylindrical</b> Stainless steel shell, shell length SL 603 – 952 mm	83	83	20	35	3	21	5	FW – 10	FW + 6	FW + 46



**DRUM MOTOR  
DL SERIES  
DL 0080**



**DL series**

**DM series**

**DP series**

**Application notes**



## Technical data

	<b>Asynchronous squirrel cage motor, IEC 34 (VDE 0530)</b>
<b>Insulation class of motor windings</b>	Class F, IEC 34 (VDE 0530)
<b>Voltage</b>	230/400 V $\pm 5\%$ (IEC 34/38)
<b>Frequency</b>	50 Hz
<b>Shaft seal, internal</b>	NBR
<b>Shaft seal, external</b>	Deflection seal, NBR
<b>Protection rate</b>	IP66 (with grease nipple)
<b>Thermal controller</b>	Bi-metal switch
<b>Operating mode</b>	S1
<b>Ambient temperature, 3-phase motor</b>	+5 to +40 °C Low temperature ranges on request
<b>Ambient temperature, 1-phase motor</b>	+5 to +40 °C

## Design variants and accessories

<b>Lagging</b>	Lagging for friction drive belts
<b>Oils</b>	Food-grade oils (EU, FDA)
<b>Certificate</b>	cULus safety certificates
<b>Accessories</b>	Idler pulleys; conveyor rollers; mounting brackets; cables; inverters
<b>Options</b>	Static balancing

# DRUM MOTOR

## DL SERIES

### DL 0113

#### Material variants

Component	Version	Aluminum	Mild steel	Stainless steel	Brass/nickel	Technopolymer
Shell	Crowned		●	●		
	Cylindrical		●	●		
End housing	Standard	●		●		
Shaft cap	Standard	●				
	With cable protection	●				
	Regreasable			●		
Gear boxes	Planetary gear box					●
Electrical connector	Straight connector			●	●	
	Elbow connector			●		
	Terminal box	●		●		
Motor winding	Asynchronous motor					
External seal	NBR					

# DRUM MOTOR DL SERIES DL 0113

## Motor variants

### Mechanical data for 3-phase asynchronous motor

$P_N$ [W]	$n_p$	gs	i	v [m/s]	$n_A$ [min <sup>-1</sup> ]	$M_A$ [Nm]	$F_N$ [N]	$FW_{MIN}$ [mm]	$SL_{MIN}$ [mm]
40	8	3	63.00	0.068	11.4	28.6	505	282	260
40	8	3	49.29	0.087	14.6	22.4	395	282	260
40	8	3	38.51	0.111	18.7	17.5	309	282	260
110	4	3	63.00	0.129	21.7	41.6	734	262	240
110	4	3	49.29	0.164	27.7	32.5	574	262	240
110	4	3	44.09	0.184	31.0	29.1	514	262	240
110	4	3	38.51	0.210	35.4	25.4	449	262	240
110	4	3	30.77	0.263	44.4	20.3	359	262	240
110	4	3	26.84	0.302	50.9	17.7	313	262	240
110	4	3	23.96	0.338	57.0	15.8	279	262	240
110	4	2	15.00	0.540	91.0	10.4	184	262	240
110	4	2	11.57	0.700	118.0	8.0	142	262	240
110	4	2	10.27	0.788	132.9	7.1	126	262	240
110	4	2	8.88	0.912	153.8	6.2	109	262	240
110	4	2	7.86	1.031	173.7	5.5	96	262	240
160	4	3	44.09	0.182	30.6	42.7	754	282	260
180	4	3	38.51	0.209	35.2	41.9	470	297	275
180	4	3	30.77	0.261	44.0	33.5	591	297	275
180	4	3	26.84	0.300	50.5	29.2	516	297	275
180	4	3	23.96	0.335	56.6	26.1	461	297	275
180	4	2	15.00	0.536	90.3	17.2	303	297	275
180	4	2	11.57	0.695	117.1	13.3	234	297	275
180	4	2	10.27	0.782	131.9	11.8	208	297	275
180	4	2	8.88	0.905	152.6	10.2	180	297	275
180	4	2	7.86	1.023	172.5	9.0	159	297	275

# DRUM MOTOR

## DL SERIES

### DL 0113

$P_N$ [W]	$n_p$	gs	i	v [m/s]	$n_A$ [min <sup>-1</sup> ]	$M_A$ [Nm]	$F_N$ [N]	$FW_{MIN}$ [mm]	$SL_{MIN}$ [mm]
330	2	3	44.09	0.377	63.5	42.7	754	297	275
330	2	3	38.51	0.431	72.7	37.3	659	297	275
330	2	3	30.77	0.540	91.0	29.8	526	297	275
330	2	3	26.84	0.619	104.3	26.0	459	297	275
330	2	3	23.96	0.693	116.9	23.2	410	297	275
330	2	2	15.00	1.107	186.7	15.3	270	297	275

$P_N$	= Rated power	$n_A$	= Shell rated speed
$n_p$	= Number of poles	$M_A$	= Drum motor rated torque
gs	= Gear stages	$F_N$	= Drum motor rated belt pull
i	= Speed ratio	$FW_{MIN}$	= Minimum drum width
v	= Speed	$SL_{MIN}$	= Minimum shell length

#### Electrical data for 3-phase asynchronous motor

$P_N$ [W]	$n_p$	$n_N$ [min <sup>-1</sup> ]	$f_N$ [Hz]	$U_N$ [V]	$I_N$ [A]	cos $\varphi$	$\eta$ [%]	$J_R$ [kgcm <sup>2</sup> ]	$I_s/I_N$	$M_s/M_N$	$M_B/M_N$	$M_P/M_N$	$M_N$ [Nm]	$R_M$ [ $\Omega$ ]	$U_{SH\Delta}$ [V]	$U_{SHY}$ [V]
40	8	720	50	230	0.64	0.58	0.27	3.9	1.53	1.59	1.59	1.49	0.53	187.5	35	–
40	8	720	50	400	0.37	0.58	0.27	3.9	1.53	1.59	1.59	1.49	0.53	187.5	–	60
110	4	1365	50	230	0.8	0.73	0.47	2.3	3.65	3.38	3.39	3.38	0.77	84	25	–
110	6	865	50	400	0.62	0.62	0.41	4	2.03	3.14	3.35	3.14	1.21	92	–	53
110	4	1365	50	400	0.45	0.75	0.47	2.3	3.64	3.41	3.42	3.41	0.77	84	–	43
160	4	1350	50	230	0.98	0.76	0.54	3.3	4.02	3.22	3.33	3.22	1.13	59.2	22	–
160	4	1350	50	400	0.57	0.75	0.54	3.3	3.98	3.25	3.35	3.25	1.13	59.2	–	38
180	4	1355	50	230	1	0.77	0.59	4	4.37	3.54	3.74	3.54	1.27	45.5	18	–
180	4	1355	50	400	0.62	0.76	0.55	4	4.42	3.6	3.79	3.6	1.27	45.5	–	32
330	2	2800	50	230	1.74	0.76	0.68	3.3	4.5	3.57	3.57	2.62	1.13	21.5	14	–
330	2	2800	50	400	0.93	0.76	0.68	3.3	4.5	3.57	3.57	2.62	1.13	21.5	–	23

$P_N$	= Rated power	$I_s/I_N$	= Ratio of startup current – rated current
$n_p$	= Number of poles	$M_s/M_N$	= Ratio of startup torque – rated torque
$n_N$	= Rated speed of rotor	$M_B/M_N$	= Ratio of pull-out torque – rated torque
$f_N$	= Rated frequency	$M_P/M_N$	= Ratio of pull-up torque – rated torque
$U_N$	= Rated voltage	$M_N$	= Rated torque of rotor
$I_N$	= Rated current	$R_M$	= Branch resistance
cos $\varphi$	= Power factor	$U_{SH\Delta}$	= Heater voltage in delta connection
$\eta$	= Efficiency	$U_{SHY}$	= Heater voltage in star connection
$J_R$	= Rotor moment of inertia		

# DRUM MOTOR DL SERIES DL 0113

## Mechanical data for 1-phase asynchronous motor

$P_N$ [W]	$n_p$	gs	i	v [m/s]	$n_A$ [min <sup>-1</sup> ]	$M_A$ [Nm]	$F_N$ [N]	$FW_{MIN}$ [mm]	$SL_{MIN}$ [mm]
60	4	3	63.00	0.122	20.6	23.8	420	262	240
60	4	3	49.29	0.156	26.4	18.6	328	262	240
60	4	3	44.09	0.175	29.5	16.6	294	262	240
60	4	3	38.51	0.200	33.8	14.5	256	262	240
60	4	3	30.77	0.251	42.3	11.6	205	262	240
60	4	3	26.84	0.287	48.4	10.1	179	262	240
60	4	3	23.96	0.322	54.3	9.0	160	262	240
60	4	2	15.00	0.514	86.7	6.0	105	262	240
110	4	3	63.00	0.122	20.6	43.8	772	282	260
110	4	3	49.29	0.156	26.4	34.2	604	282	260
110	4	3	44.09	0.175	29.5	30.6	541	282	260
110	4	3	38.51	0.200	33.8	26.7	472	282	260
110	4	3	30.77	0.251	42.3	21.4	377	282	260
110	4	3	26.84	0.287	48.4	18.6	329	282	260
110	4	3	23.96	0.322	54.3	16.6	294	282	260
110	4	2	15.00	0.514	86.7	11.0	194	282	260
110	4	2	11.57	0.666	112.3	8.5	149	282	260

$P_N$  = Rated power  
 $n_p$  = Number of poles  
 gs = Gear stages  
 i = Speed ratio  
 v = Speed

$n_A$  = Shell rated speed  
 $M_A$  = Drum motor rated torque  
 $F_N$  = Drum motor rated belt pull  
 $FW_{MIN}$  = Minimum drum width  
 $SL_{MIN}$  = Minimum shell length

# DRUM MOTOR

## DL SERIES

### DL 0113

#### Electrical data for 1-phase asynchronous motor

$P_N$ [W]	$n_p$	$n_N$ [min <sup>-1</sup> ]	$f_N$ [Hz]	$U_N$ [V]	$I_N$ [A]	$\cos\varphi$	$\eta$ [%]	$J_R$ [kgcm <sup>2</sup> ]	$I_s/I_N$	$M_s/M_N$	$M_B/M_N$	$M_P/M_N$	$M_N$ [Nm]	$R_M$ [Ω]	$U_{SH \sim}$ [V DC]	$C_R$ [μF]
60	4	1300	50	230	0.75	0.98	0.36	2.3	2.58	1.29	2.6	1.29	0.44	63.5	35	4
110	4	1300	50	230	1.13	0.88	0.48	3.3	2.93	1.06	2.31	1.06	0.81	32.5	24	6

$P_N$	= Rated power	$I_s/I_N$	= Ratio of startup current – rated current
$n_p$	= Number of poles	$M_s/M_N$	= Ratio of startup torque – rated torque
$n_N$	= Rated speed of rotor	$M_B/M_N$	= Ratio of pull-out torque – rated torque
$f_N$	= Rated frequency	$M_P/M_N$	= Ratio of pull-up torque – rated torque
$U_N$	= Rated voltage	$M_N$	= Rated torque of rotor
$I_N$	= Rated current	$R_M$	= Branch resistance
$\cos\varphi$	= Power factor	$U_{SH \sim}$	= Heater voltage for DC units
$\eta$	= Efficiency	$C_R$	= Capacitor size
$J_R$	= Rotor moment of inertia		



## Belt tension diagrams

### Belt tension depending on drum width

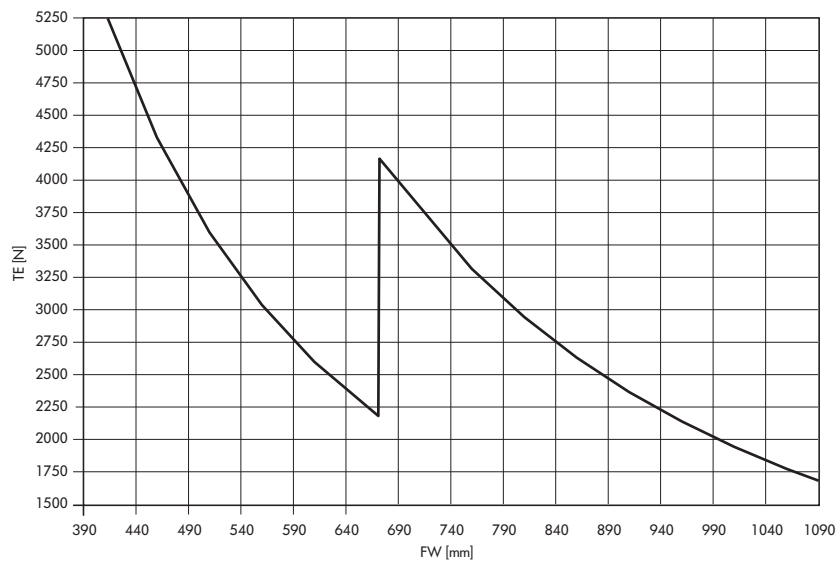

### Belt tension depending on rated speed of shell

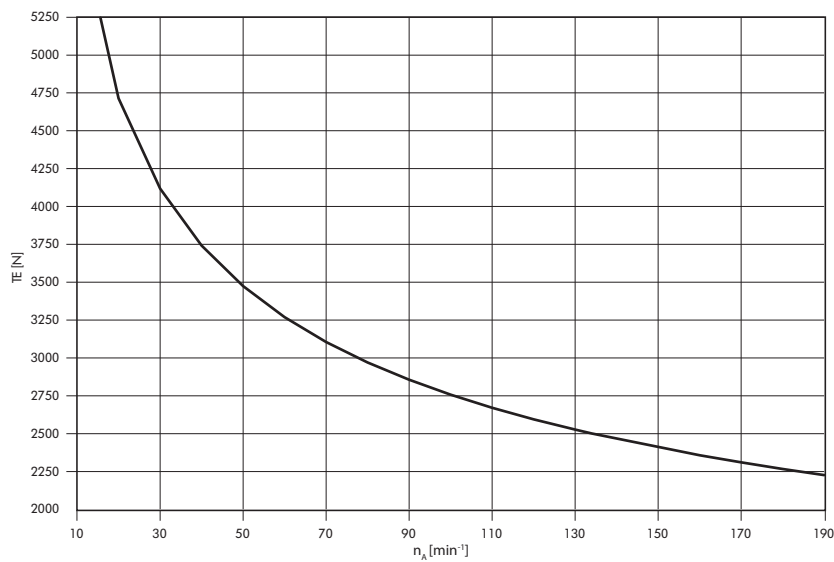

**Note:** The correct value for the maximum permissible belt tension is determined from the maximum permissible TE value for the speed of the drum motor. For motors with shell length FW > 400 mm, check whether the maximum permissible TE value for the jacket length is lower. In this case, use the lower value as maximum permissible TE value.

- TE = Belt tension
- $n_A$  = Shell rated speed
- FW = Drum width

# DRUM MOTOR

## DL SERIES

### DL 0113

#### Dimensions

#### Drum motor

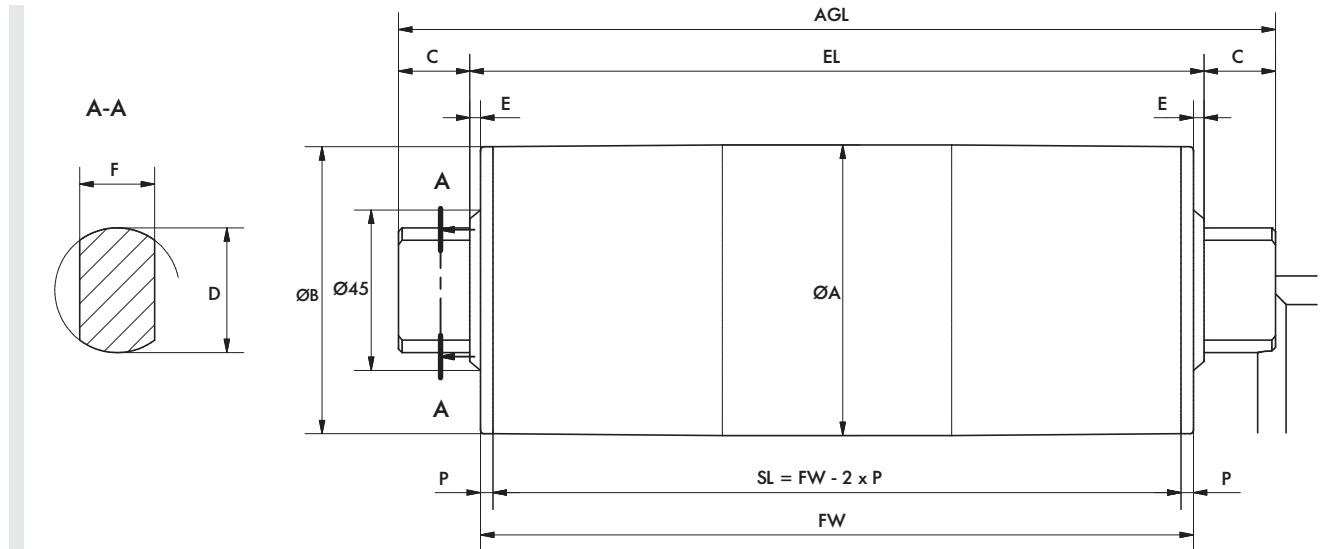

Type	A [mm]	B [mm]	C [mm]	D [mm]	S [mm]	F [mm]	P [mm]	SL [mm]	EL [mm]	AGL [mm]
DL 0113 crowned	113.3	112.4	20	35	3	21	11	FW - 22	FW + 6	FW + 46
DL 0113 cylindrical	113.0	113.0	20	35	3	21	11	FW - 22	FW + 6	FW + 46

**DRUM MOTOR  
DL SERIES  
DL 0113**



**DL series**

**DM series**

**DP series**

**Application notes**

# DL SERIES LAGGING AND COATING LAGGING

For friction drive belt applications



## Hygienic and loadable

A lagging provides an advantage for drum motors, particularly for wet applications and in food processing, with its typical hygienic requirements. A lagging increases the friction between drum motor and conveyor belt, thereby preventing slippage. On top of that, it is resistant to external influences such as oil, fuels, and other chemicals that may be used for cleaning. Depending on the application, different profiles are available: For high volumes of liquid, a longitudinal grooved lagging redirects moisture between belt and motor, a center V-groove ensures precise belt tracking. Laggings are available in cold and hot vulcanization, whereby the latter meets particularly strict hygiene requirements.

**Note:** It is important to incorporate a calculation of belt pull and speed that is adjusted to the greater outer diameter of the drum motor.

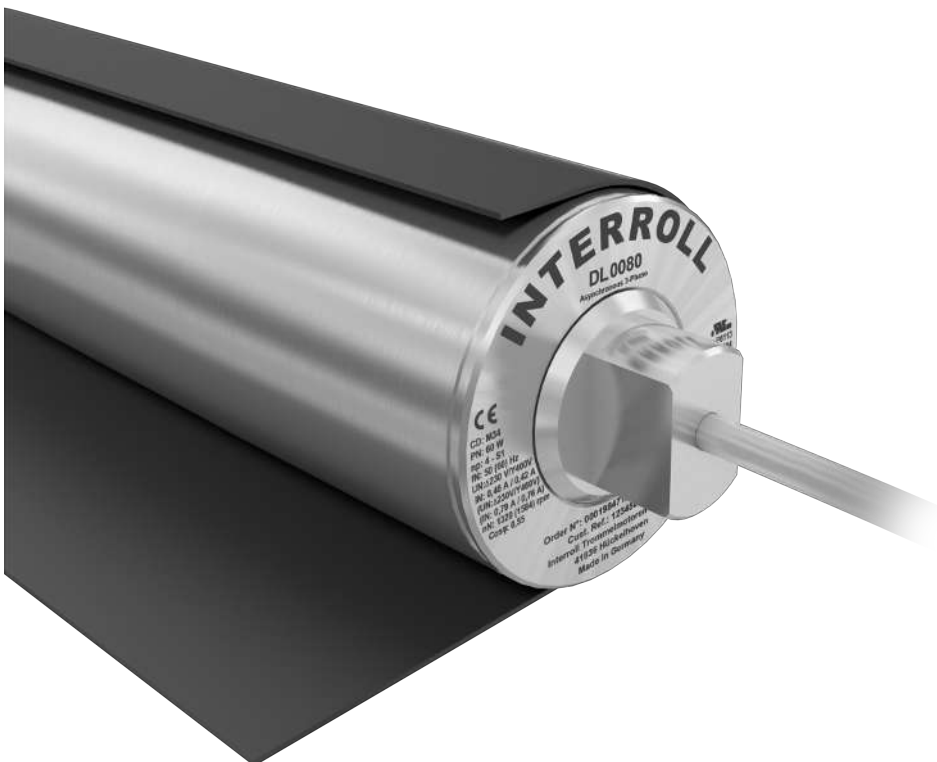

# DL SERIES LAGGING AND COATING LAGGING

For friction drive belt applications

## Technical data

<b>Material</b>	Hot or cold-vulcanized NBR, other materials upon request.
<b>Temperature range</b>	-40 to +120 °C
<b>Shore hardness</b>	65 and 70 ± 5 Shore A

## Versions

### Cold vulcanization

Lagging profile	Color	Features	Shore hardness	Thickness [mm]
Smooth	Black	Oil- and grease-resistant	65 ± 5 Shore A	3; 4
	White	FDA food approved	70 ± 5 Shore A	
Longitudinal grooves	White	FDA food approved	70 ± 5 Shore A	8

### Hot vulcanization

Lagging profile	Color	Features	Shore hardness	Thickness [mm]
Smooth	Black	Oil- and grease-resistant	65 ± 5 Shore A	2; 3; 4; 5; 6; 8; 10; 12; 14; 16
	White/blue	FDA food approved EC1935/2004 approved	70 ± 5 Shore A	
Longitudinal grooves	Black	Oil- and grease-resistant	65 ± 5 Shore A	6; 8; 10; 12; 14; 16
	White/blue	FDA food approved EC1935/2004 approved	70 ± 5 Shore A	

# DL SERIES LAGGING AND COATING LAGGING

For friction drive belt applications

## Dimensions

### Smooth

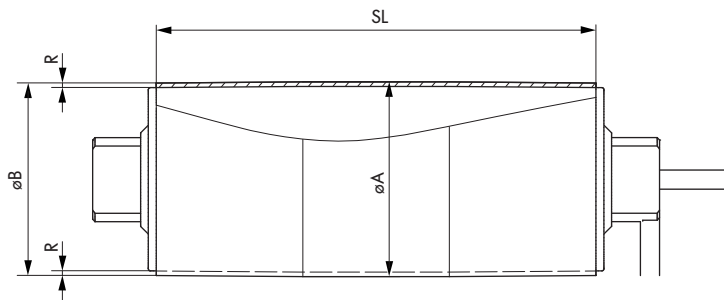

The standard cambers of the lagging are available in the following table.

Drum motor	Ø Tube [mm]	Cold vulcanization			Hot vulcanization		
		Min./max. R [mm]	Ø A [mm]	Ø B [mm]	Min./max. R [mm]	Ø A [mm]	Ø B [mm]
DL 0080	81.5	3	87.5	86.0	2	85.5	84.0
		4	89.5	88.0	6	93.5	92.0
DL 0113	113.3	3	119.3	117.8	2	117.5	115.8
		4	121.3	119.8	6	125.3	123.8

# DL SERIES CABLE OVERVIEW AND CONNECTION DIAGRAMS CABLE OVERVIEW

## Cable overview

### Cable connections

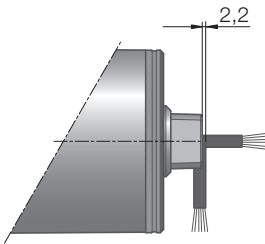

Fig.: Shaft cap, standard, aluminum

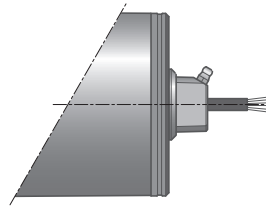

Fig.: Straight cable connector with regreasable shaft cap, stainless steel

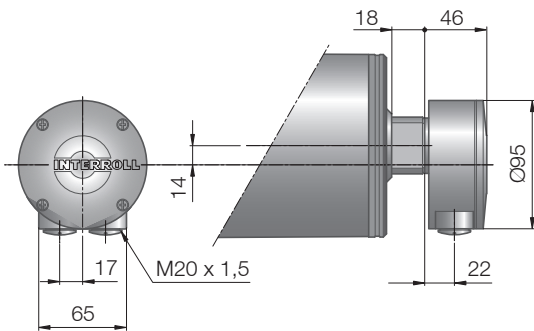

Fig.: Terminal box, aluminum

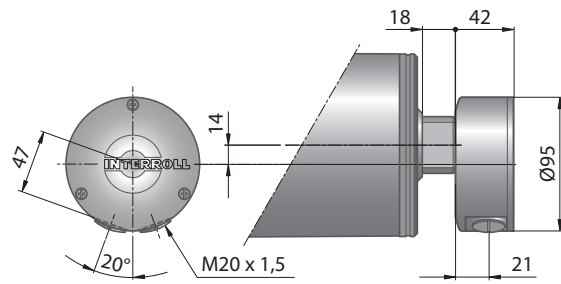

Fig.: Terminal box, stainless steel

# DL SERIES

## CABLE OVERVIEW AND CONNECTION DIAGRAMS

### CABLE OVERVIEW

#### Cable types of DL series

The product pages feature a selection of straight cable connectors and elbow connectors for the following cables (including optional terminal boxes); they are suitable for most standard applications. Available cable lengths are 1 m, 3 m, and 5 m.

To operate the motor via a frequency inverter, please use a shielded cable in order to reduce EMC emissions.

PUR cables or externally shielded cables may not be suitable for some applications in the food processing sector. An optional blue cable protection can be ordered for those applications. It protects the cable against UV light and cleaning agents. Please select a matching cable connector on the product pages when ordering the blue cable protection.

Article number	1000583	1000584	1000595	1000569	1000577	1107481
Main cores	9	6	6	7	6	7
Cross section	0.75 mm <sup>2</sup>	0.75 mm <sup>2</sup>	0.75 mm <sup>2</sup>	0.75 mm <sup>2</sup>	0.75 mm <sup>2</sup>	0.5 mm <sup>2</sup>
Numeric code and color code (main cores)	Numeric code + color code	Color code	Color code	Numeric code + color code	Color code	Numeric code + color code
Insulation conductors (main cores)	PVC	PVC	PP	PVC	PP	ETFE
Data cores (number)	–	–	–	–	–	2
Insulation conductors (data cores)	–	–	–	–	–	ETFE
Numeric code and color code (data cores)	–	–	–	–	–	Color code
Insulation of outer sheath	PVC	PVC	PUR	PVC	PUR	PVC
Halogen-free	No	No	Yes	No	Yes	No
Color of outer sheath	Black	Black	Gray	Black	Gray	Gray
Shielded	–	–	–	–	Copper	Copper-tinned
Outside diameter	7.3 mm	7.15 mm	7.15 mm	7.15 mm	7.15 mm	7.7 ± 0.2 mm
Operating voltage	460/800 V	460/800 V	450/750 V	300/500 V	460/800 V	600 V
Operating voltage according to UL	300/500 V	300/500 V	340/600 V	300/500 V	300/500 V	600 V
Temperature range	–40 to +105 °C –40 to +80 °C according to UL	–40 to +105 °C –40 to +80 °C according to UL	–40 to +90 °C –40 to +80 °C according to UL	–40 to +105 °C –40 to +80 °C according to UL	–40 to +105 °C –40 to +80 °C according to UL	–40 to +105 °C according to UL
Approval	cULus	cULus	cULus	cULus	cULus	cULus



# DL SERIES

## CABLE OVERVIEW AND CONNECTION DIAGRAMS

### CONNECTION DIAGRAMS

### Connection diagrams

#### Abbreviations

ye/gn	= yellow/green	or	= orange
bn	= brown	vi	= violet
bk	= black	rd	= red
gy	= gray	wh	= white
bu	= blue	FC	= Frequency inverter for permanent magnet synchronous motors
TC	= Thermal controller (bi-metal switch)	NC	= Not connected
BR	= Electromagnetic brakes		

#### Rotation

**Note:** The rotational direction of the drum motor is shown on the connection diagrams. The rotation indicated is correct when looking at the motor from the connection side.

#### Cable connections 3-phase asynchronous motor

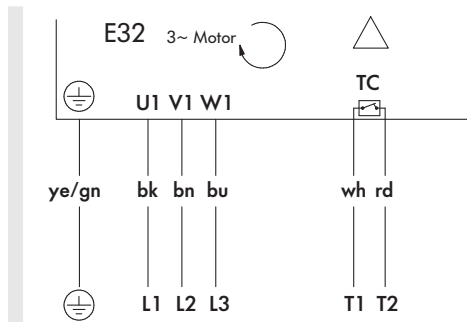

Fig.: 3-phase, 6-core cable, winding for 1 voltage, delta connection

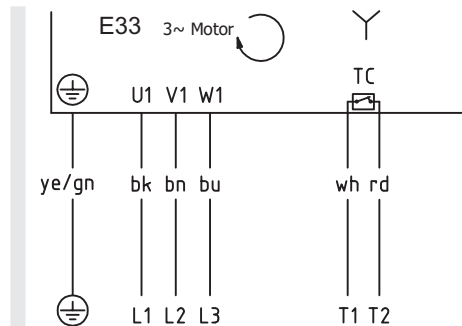

Fig.: 3-phase, 6-core cable, winding for 1 voltage, star connection

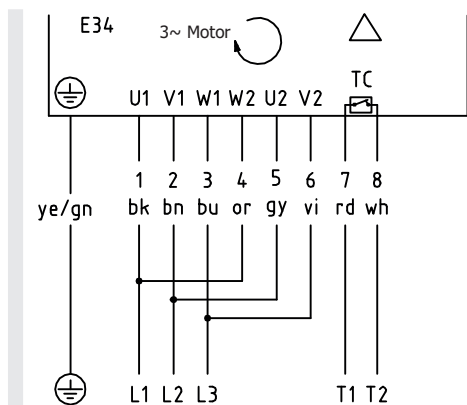

Fig.: 3-phase, 9-core cable, winding for 2 voltages, delta connection

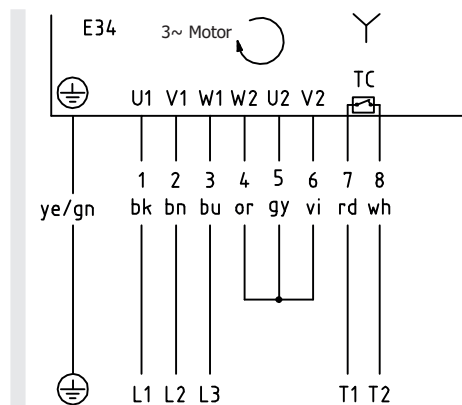

Fig.: 3-phase, 9-core cable, winding for 2 voltages, star connection

# DL SERIES

## CABLE OVERVIEW AND CONNECTION DIAGRAMS

### CONNECTION DIAGRAMS

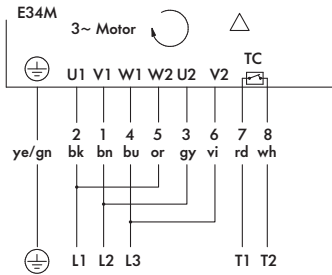

Fig.: 3-phase, 7+2 core cable, winding for 2 voltages, delta connection

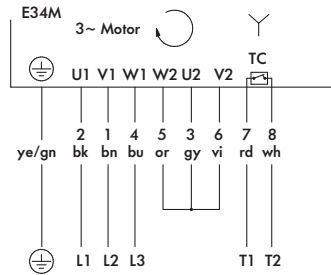

Fig.: 3-phase, 7+2-core cable, winding for 2 voltages, star connection

#### Cable connections 1-phase asynchronous motor

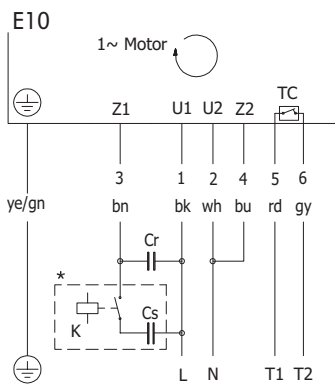

Fig.: 1-phase, 7-core cable

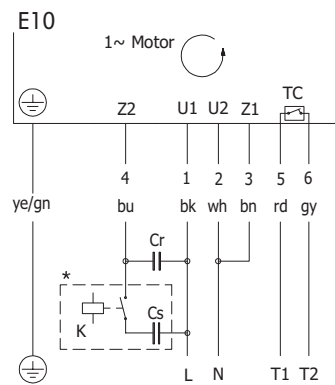

Fig.: 1-phase, 7-core cable

#### Terminal box 3-phase asynchronous motor

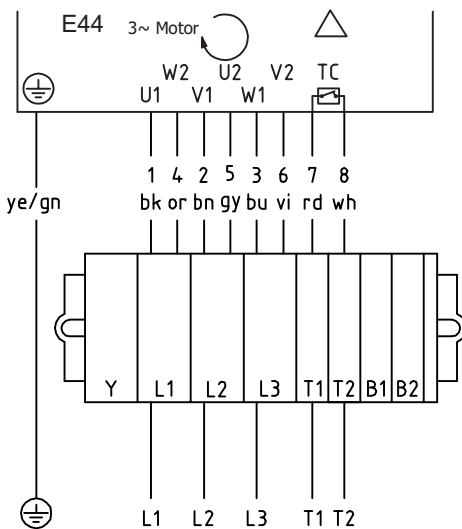

Fig.: 3-phase, 9-core cable, winding for 2 voltages, delta connection

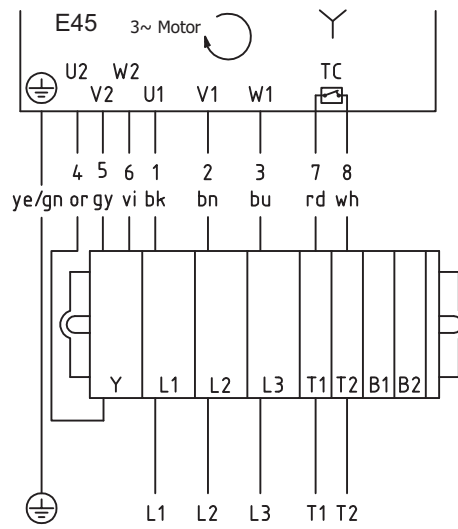

Fig.: 3-phase, 9-core cable, winding for 2 voltages, star connection

# DL SERIES CABLE OVERVIEW AND CONNECTION DIAGRAMS CONNECTION DIAGRAMS

## Terminal box 1-phase asynchronous motor

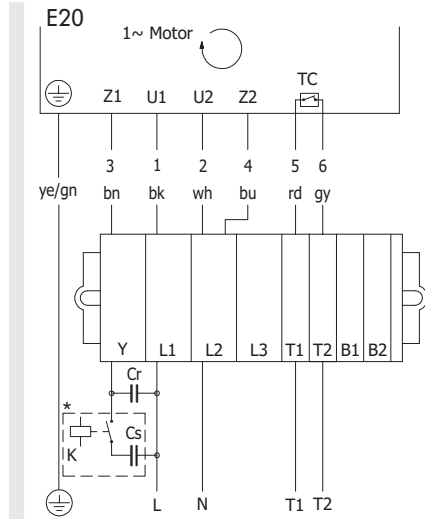

Fig.: 1-phase, 7-core cable

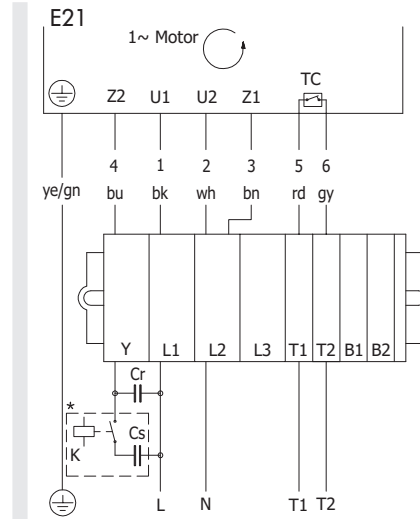

Fig.: 1-phase, 7-core cable

For more information about the starting relay, see page 190

# DL SERIES OPTIONS AND ACCESSORIES ANTI-VIBRATION BRACKETS

## Anti-vibration brackets



### Product description

Anti-vibration bracket with rubber insulation part for reduction of noise and vibration. The bracket is designed so that the drum motor shaft is secured should the rubber become damaged.

With 2 brackets fitted, max. torque of drum motor must be limited to 40 Nm (354 lbf).

### Dimensions

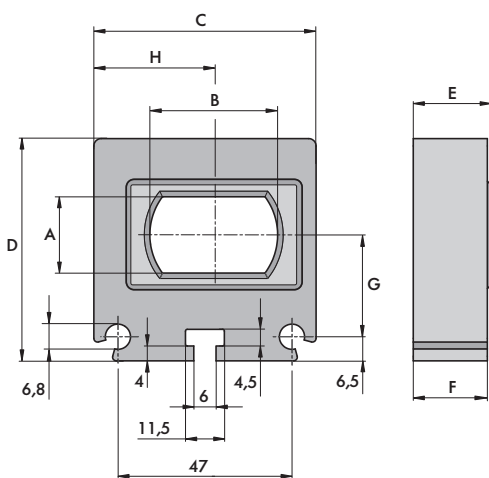

Fig.: Anti-vibration brackets

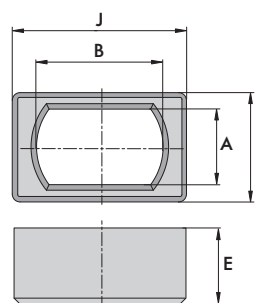

Fig.: Rubber

A	B	C	D	S	F	G	H	I	J
[mm]	[mm]	[mm]	[mm]	[mm]	[mm]	[mm]	[mm]	[mm]	[mm]
20.5	34.5	60.0	60.0	21.0	20.0	27.6	32.5	30.0	47.75

### Product selection

Article	Art. No.
Anti-vibration brackets	61103929
Rubber	1000455

# DL SERIES

## OPTIONS AND ACCESSORIES

### LIGHT DUTY FLANGED BRACKET FOR DRUM MOTOR

#### Light duty flanged bracket for drum motor



#### Product description

Set of brackets for mounting a drum motor

#### Dimensions

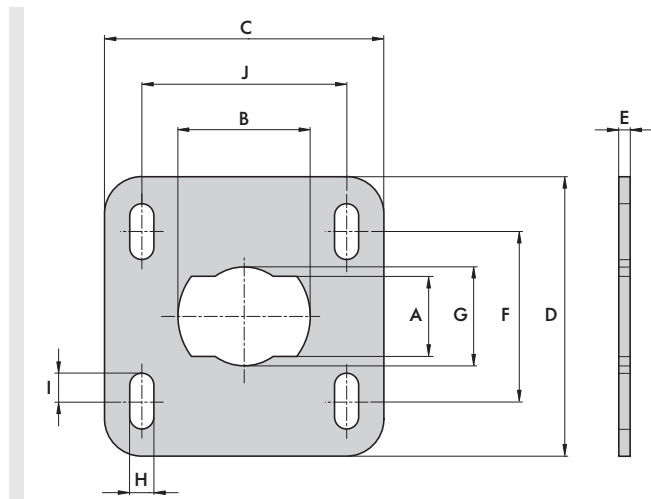

A	B	C	D	S	F	G	H	I	J
[mm]	[mm]	[mm]	[mm]	[mm]	[mm]	[mm]	[mm]	[mm]	[mm]
21.5	35.5	75.0	75.0	3.0	45.5	26.5	6.5	15.0	55.0

#### Product selection

Article	Shaft [mm]	Material	Art. No.
DL 0080 / 0113	21 x 35	Stainless steel	61103896

# DL SERIES OPTIONS AND ACCESSORIES LIGHT DUTY FLANGED BRACKET FOR IDLER PULLEY

## Light duty flanged bracket for idler pulley

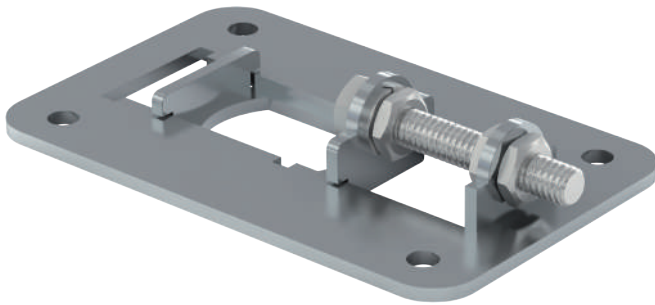

### Product description

Set of brackets for mounting an idler pulley

### Dimensions

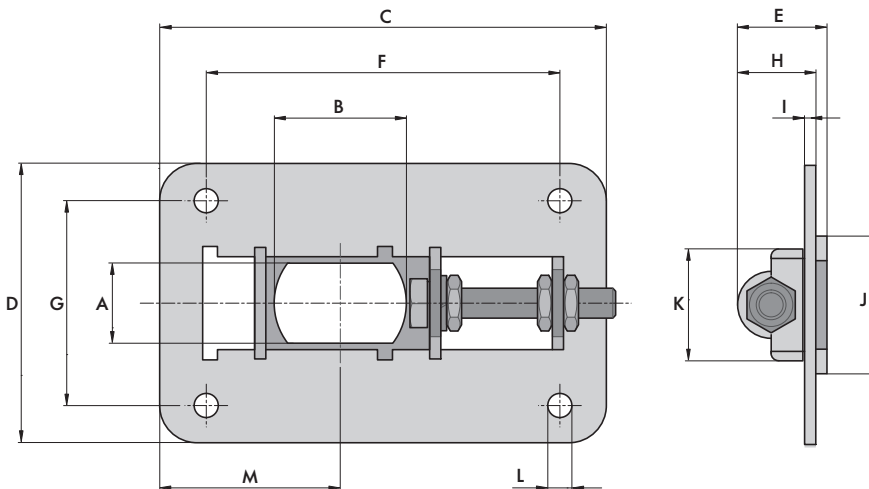

A	B	C	D	S	F	G	H	I	J	K	L	M <sub>min</sub>	M <sub>max</sub>
[mm]	[mm]	[mm]	[mm]	[mm]	[mm]	[mm]	[mm]	[mm]	[mm]	[mm]	[mm]	[mm]	[mm]
21.5	35.5	120.0	75.0	24.0	95.0	55.0	21.0	3.0	37.0	30.0	6.5	35.0	79.0

### Product selection

Article	Shaft [mm]	Material	Art. No.
DL 0080 / 0113	21 x 35	Stainless steel	61103898

# DL SERIES OPTIONS AND ACCESSORIES LIGHT DUTY FLANGED BRACKET FOR IDLER PULLEY

---

DL series

DM series

DP series

Application notes

# DL SERIES OPTIONS AND ACCESSORIES IDLER PULLEY WITH INTEGRATED BEARINGS

---



Interroll deflection rollers can be used on the driven side of conveyor belts. The deflection roller with integrated bearings has a fixed shaft and the same dimensions as a drum motor.





# DL SERIES

## OPTIONS AND ACCESSORIES

### IDLER PULLEY WITH INTEGRATED BEARINGS

#### Technical data

Protection rate	IP66
Max. belt tension	See equivalent drum motor
Max. belt speed	See equivalent drum motor
Drum width	See equivalent drum motor
Internal shaft sealing system	NBR
External shaft sealing system	NBR

#### Design versions

For idler pulleys you can choose the following design versions:

Component	Option	Material			
		Aluminum	Mild steel	Stainless steel	PTFE
Shell	Crowned		●	●	
	Cylindrical		●	●	
End housing		●		●	
Shaft cap				●	
External seal	NBR				●

#### Versions

- Laggings for friction drive belts, page 28

# DL SERIES OPTIONS AND ACCESSORIES IDLER PULLEY WITH INTEGRATED BEARINGS

## Dimensions

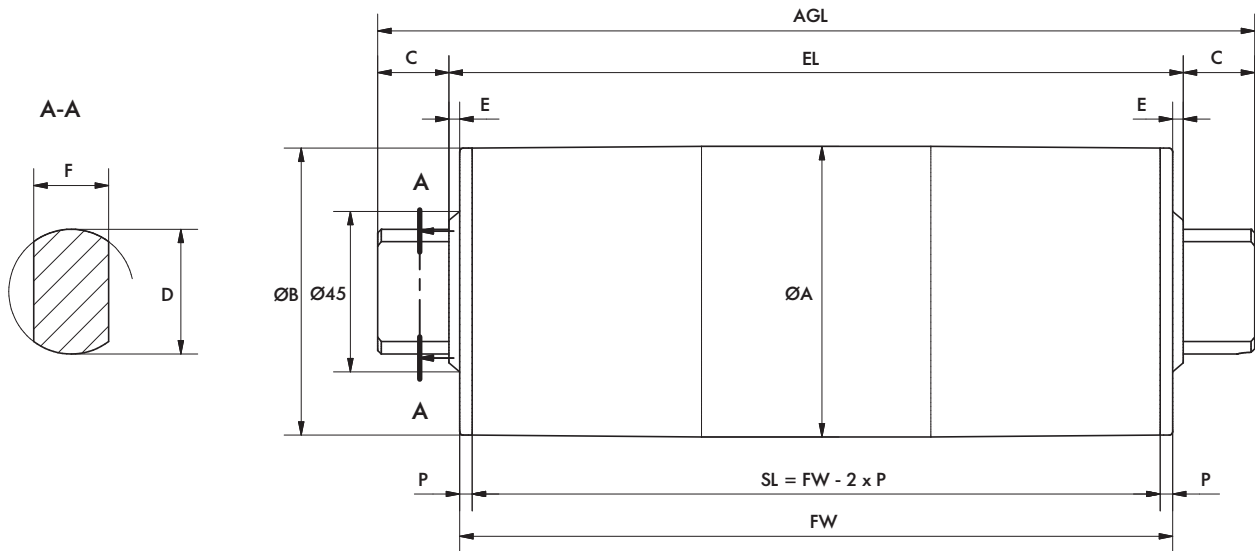

Type	A [mm]	B [mm]	C [mm]	D [mm]	S [mm]	F [mm]	P [mm]	SL [mm]	EL [mm]	AGL [mm]
<b>IL 0080 crowned</b> Shell length SL 260 – 602 mm	81.5	80.0	20	35	3	21	5	FW – 10	FW + 6	FW + 46
<b>IL 0080 crowned</b> Mild steel shell, shell length SL 603 – 952 mm	82.7	81.0	20	35	3	21	5	FW – 10	FW + 6	FW + 46
<b>IL 0080 crowned</b> Stainless steel shell, shell length SL 603 – 952 mm	83.0	80.0	20	35	3	21	5	FW – 10	FW + 6	FW + 46
<b>IL 0080 cylindrical</b> Shell length SL 260 – 602 mm	80.5	80.5	20	35	3	21	5	FW – 10	FW + 6	FW + 46
<b>IL 0080 cylindrical</b> Mild steel shell, shell length SL 603 – 952 mm	83.0	83.0	20	35	3	21	5	FW – 10	FW + 6	FW + 46
<b>IL 0080 cylindrical</b> Stainless steel shell, shell length SL 603 – 952 mm	82.7	82.7	20	35	3	21	5	FW – 10	FW + 6	FW + 46
<b>IL 0113 crowned</b>	113.3	112.4	20	35	3	21	11	FW – 22	FW + 6	FW + 46
<b>IL 0113 cylindrical</b>	113.0	113.0	20	35	3	21	11	FW – 22	FW + 6	FW + 46

**DL SERIES  
OPTIONS AND ACCESSORIES  
IDLER PULLEY WITH INTEGRATED BEARINGS**

---

**DL series**

**DM series**

**DP series**

**Application notes**

# DRUM MOTOR

## DM SERIES

### DM 0080



Practice-oriented, scalable and thought out in detail: The new drum motor DM 0080 makes it easy to build a completely individual conveyor system and is dimensioned for the higher requirements of permissible belt tension now demanded from industry and belt manufacturers alike.

With a broader speed spectrum, the DM 0080 covers all possible applications. The clever plug-and-play connection significantly simplifies the installation. Each motor is approved, tested, and modularized so that it can be produced and delivered around the world in the shortest amount of time.

The modular design of the DM 0080 allows a free combination of individual module groups, such as shaft, end housing, shell, steel or technopolymer gear, asynchronous or synchronous motor winding, to perfectly meet the requirements of an application. In addition, various options, such as encoder, brake, backstop, rubber laggings, etc., as well as different accessories are available.

With the platform concept of the DM 0080, it is possible to cover all internal logistics applications in the food processing sector, as well as in industry, distribution and airports.

The DM 0080 synchronous drum motor is also offered as oil-free variant. It is ideal for highly dynamic applications, conveyor systems in food processing, SmartBelt conveyors and many belt conveyors with servo driver.



## Technical data

	Asynchronous squirrel cage motor	AC synchronous permanent magnet motor
<b>Insulation class of motor windings</b>	Class F, IEC 34 (VDE 0530)	Class F, IEC 34 (VDE 0530)
<b>Voltage</b>	230/400 V $\pm 5\%$ (IEC 34/38) Most of the common international voltages and frequencies are available upon request	230 or 400 V
<b>Frequency</b>	50 Hz	200 Hz
<b>Shaft seal, internal</b>	NBR	NBR
<b>Protection rate Motor*</b>	IP69K	IP69K
<b>Thermal controller</b>	Bi-metal switch	Bi-metal switch
<b>Operating mode</b>	S1	S1
<b>Ambient temperature, 3-phase motor</b>	+2 to +40 °C Low temperature ranges on request	+2 to +40 °C Low temperature ranges on request
<b>Ambient temperature, 3-phase motor for applications with form-fit belts or no belt</b>	+2 to +25 °C	+2 to +40 °C

\* The protection rate of the cable connector may deviate.

## Design variants and accessories

<b>Laggings</b>	Lagging for friction drive belts Lagging for modular plastic belts Lagging for positive drive solid homogeneous belts
<b>Sprockets</b>	Sprockets
<b>Options</b>	Backstop Electromagnetic holding brake and rectifier* Encoder* Balancing Plug connection*
<b>Oils</b>	Food-grade oils (EU, FDA, NSF H1) Synchronous motors also available as oil-free variants
<b>Certificate</b>	cULus safety certificates
<b>Accessories</b>	Idler pulleys; conveyor rollers; mounting brackets; cables; inverters

A combination of encoder and safety holding brake is not possible. In addition, the use of a backstop with a synchronous motor is technically not meaningful.

\* Depending on the option, the motor extends by 50 – 70 mm.

# DRUM MOTOR

## DM SERIES

### DM 0080

#### Material variants

The following components can be selected for the drum motor and the electrical connection. The combination of components depends on the material used.

Component	Version	Aluminum	Mild steel	Stainless steel	Brass/nickel	Technopolymer
<b>Shell</b>	Crowned		●	●		
	Cylindrical		●	●		
	Cylindrical + key for sprockets		●	●		
<b>End housing</b>	Standard	●		●		
<b>Shaft</b>	Standard			●		
	Cross-drilled thread			●		
<b>Gear boxes</b>	Planetary gear box		●			●
<b>Electrical connector</b>	Straight connector			●	●	●
	Straight hygienic connector			●		
	Elbow connector			●		●
	Terminal box	●		●		●
	Straight plug connection			●		
	90° plug connection			●		
	90° hygienic connector			●		
<b>Motor winding</b>	Asynchronous motor					
	Synchronous motor					
<b>External seal</b>	PTFE					

# DRUM MOTOR DM SERIES DM 0080

## Motor variants

### Mechanical data for synchronous motors with steel gear

$P_N$ [W]	$n_p$	$g_s$	$i$	$v$ [m/s]	$n_A$ [min <sup>-1</sup> ]	$M_A$ [Nm]	$F_N$ [N]	$M_{MAX}/M_A$	$FW_{MIN}$ [mm]	$SL_{MIN}$ [mm]
145	8	3	164.23	0.08	18.3	65.0	1594	1.4	211	204
145	8	3	119.83	0.11	25.0	47.4	1163	2.1	211	204
145	8	3	103.89	0.12	28.9	41.1	1009	2.5	211	204
145	8	3	85.34	0.15	35.2	33.8	828	3.0	211	204
145	8	2	62.7	0.20	47.8	26.0	637	2.2	192	185
145	8	2	53.63	0.24	55.9	22.2	545	2.5	192	185
145	8	2	42.28	0.30	71.0	17.5	430	3.0	192	185
145	8	2	38.5	0.33	77.9	15.9	391	3.0	192	185
145	8	2	31.35	0.41	95.7	13.0	319	3.0	192	185
145	8	2	26.94	0.48	111.4	11.2	274	3.0	192	185
145	8	2	20.27	0.63	148.0	8.4	206	3.0	192	185
145	8	2	14.44	0.89	207.8	6.0	147	3.0	192	185
145	8	2	11.23	1.14	267.1	4.6	114	3.0	192	185
145	8	1	8.25	1.55	363.6	3.6	88	3.0	192	185
145	8	1	4.71	2.72	636.9	2.1	51	3.0	192	185
298	8	2	53.63	0.24	55.9	45.9	1125	1.2	222	215
298	8	2	42.28	0.30	71.0	36.1	887	1.5	222	215
298	8	2	38.5	0.33	77.9	32.9	808	1.6	222	215
298	8	2	31.35	0.41	95.7	26.8	658	3.0	222	215
298	8	2	26.94	0.48	111.4	23.0	565	3.0	222	215
298	8	2	20.27	0.63	148.0	17.3	425	3.0	222	215
298	8	2	14.44	0.89	207.8	12.3	303	3.0	222	215
298	8	2	11.23	1.14	267.1	9.6	236	3.0	222	215
298	8	1	8.25	1.55	363.6	7.4	183	3.0	222	215
298	8	1	4.71	2.72	636.9	4.3	104	3.0	222	215

DL series

DM series

DP series

Application notes

# DRUM MOTOR

## DM SERIES

### DM 0080



$P_N$ [W]	$n_p$	gs	i	v [m/s]	$n_A$ [min <sup>-1</sup> ]	$M_A$ [Nm]	$F_N$ [N]	$M_{MAX}/M_A$	$FW_{MIN}$ [mm]	$SL_{MIN}$ [mm]
425	8	2	38.5	0.33	77.9	46.8	1148	1.2	252	245
425	8	2	31.35	0.41	95.7	38.1	935	3.0	252	245
425	8	2	26.94	0.48	111.4	32.7	803	3.0	252	245
425	8	2	20.27	0.63	148.0	24.6	604	3.0	252	245
425	8	2	14.44	0.89	207.8	17.5	431	3.0	252	245
425	8	2	11.23	1.14	267.1	13.6	335	3.0	252	245
425	8	1	8.25	1.55	363.6	10.6	260	3.0	252	245
425	8	1	4.71	2.72	636.9	6.0	148	3.0	252	245
550	8	2	31.35	0.41	95.7	49.4	1212	2.0	282	275
550	8	2	26.94	0.47	111.4	42.4	1041	2.3	282	275
550	8	2	20.27	0.63	148.0	31.9	783	2.9	282	275
550	8	2	14.44	0.89	207.8	22.7	558	3.0	282	275
550	8	2	11.23	1.14	267.1	17.7	434	3.0	282	275
550	8	1	8.25	1.55	363.6	13.7	337	1.9	282	275
550	8	1	4.71	2.72	636.9	7.8	192	3.0	282	275

$P_N$	= Rated power	$M_A$	= Drum motor rated torque
$n_p$	= Number of poles	$F_N$	= Drum motor rated belt pull
gs	= Gear stages	$M_{MAX}/M_A$	= Ratio of max. acceleration torque to rated torque
i	= Speed ratio	$FW_{MIN}$	= Minimum drum width
v	= Speed	$SL_{MIN}$	= Minimum shell length
$n_A$	= Shell rated speed		

#### Electrical data for synchronous motors

$P_N$ [W]	$n_p$	$U_N$ [V]	$I_N$ [A]	$I_0$ [A]	$I_{MAX}$ [A]	$f_N$ [Hz]	$\eta$	$n_N$ [1/min]	$J_R$ [kgcm <sup>2</sup> ]	$M_N$ [Nm]	$M_0$ [Nm]	$M_{MAX}$ [Nm]	$R_M$ [Ω]	$L_{SD}$ [mH]	$L_{SQ}$ [mH]	$k_e$ [V/krpm]	$T_e$ [ms]	$k_{TN}$ [Nm/A]	$U_{SH}$ [V]
145	8	230	0.81	0.81	2.43	200	0.85	3000	0.14	0.46	0.46	1.38	21.6	45.6	53.7	41.57	4.97	0.57	25.00
145	8	400	0.47	0.47	1.41	200	0.83	3000	0.14	0.46	0.46	1.38	62.5	130.7	138.0	72.23	4.41	0.98	36.00
298	8	230	1.30	1.30	3.90	200	0.86	3000	0.28	0.95	0.95	2.85	10.2	27.8	29.3	47.46	5.75	0.73	19.00
298	8	400	0.78	0.78	2.34	200	0.87	3000	0.28	0.95	0.95	2.85	29.1	81.9	94.1	83.09	6.48	1.22	32.00
425	8	230	2.30	2.30	6.90	200	0.87	3000	0.42	1.35	1.35	4.05	5.66	16.3	19.4	45.81	6.86	0.59	19.00
425	8	400	1.32	1.32	3.96	200	0.86	3000	0.42	1.35	1.35	4.05	17.6	49.8	59.0	80.80	6.70	1.02	33.00
550	8	230	2.94	2.94	8.83	200	0.90	3000	0.60	1.75	1.75	5.25	3.89	10.2	11.8	38.45	6.06	0.59	5.73
550	8	400	1.70	1.70	5.10	200	0.90	3000	0.60	1.75	1.75	5.25	9.20	24.1	27.6	66.60	6.00	1.03	23.46

$P_N$	= Rated power	$M_N$	= Rated torque of rotor
$n_p$	= Number of poles	$M_0$	= Standstill torque
$U_N$	= Rated voltage	$M_{MAX}$	= Maximum torque



# DRUM MOTOR DM SERIES DM 0080

$I_N$	= Rated current	$R_M$	= Phase to phase resistance
$I_0$	= Standstill current	$L_{SD}$	= d-axis inductance
$I_{MAX}$	= Maximum current	$L_{SQ}$	= q-axis inductance
$f_N$	= Rated frequency	$k_e$	= EMF (mutual induction voltage constant)
$\eta$	= Efficiency	$T_e$	= Electrical time constant
$n_N$	= Rated torque of rotor	$k_{TN}$	= Torque constant
$J_R$	= Rotor moment of inertia	$U_{SH}$	= Heating voltage

## Mechanical data for synchronous motors with oil-free steel gear

$P_N$ [W]	$n_p$	gs	i	v [m/s]	$n_A$ [min <sup>-1</sup> ]	$M_A$ [Nm]	$F_N$ [N]	$M_{MAX}/M_A$	$FW_{MIN}$ [mm]	$SL_{MIN}$ [mm]
80	8	2	62.7	0.20	47.8	14.1	346	3.0	192	185
80	8	2	53.63	0.24	55.9	12.1	296	3.0	192	185
80	8	2	42.28	0.30	71.0	9.5	233	3.0	192	185
80	8	2	38.5	0.33	77.9	8.7	213	3.0	192	185
80	8	2	31.35	0.41	95.7	7.1	173	3.0	192	185
80	8	2	26.94	0.47	111.4	6.1	149	3.0	192	185
80	8	2	20.97	0.63	148.0	4.6	112	3.0	192	185
80	8	2	14.44	0.89	207.8	3.2	80	3.0	192	185
80	8	2	11.23	1.14	267.1	2.5	62	3.0	192	185
80	8	1	8.25	1.55	363.6	2.0	48	3.0	192	185
80	8	1	4.71	2.72	636.9	1.1	27	3.0	192	185
110	8	2	53.63	0.24	55.9	16.9	415	3.0	222	215
110	8	2	42.28	0.30	71.0	13.3	327	3.0	222	215
110	8	2	38.5	0.33	77.9	12.1	298	3.0	222	215
110	8	2	31.35	0.41	95.7	9.9	242	3.0	222	215
110	8	2	26.94	0.47	111.4	8.5	208	3.0	222	215
110	8	2	20.27	0.63	148.0	6.4	157	3.0	222	215
110	8	2	14.44	0.89	207.8	4.5	112	3.0	222	215
110	8	2	11.23	1.14	267.1	3.5	87	3.0	222	215
110	8	1	8.25	1.55	363.6	2.7	67	3.0	222	215
110	8	1	4.71	2.72	636.9	1.6	38	3.0	222	215

# DRUM MOTOR

## DM SERIES

### DM 0080



$P_N$ [W]	$n_p$	gs	i	v [m/s]	$n_A$ [min <sup>-1</sup> ]	$M_A$ [Nm]	$F_N$ [N]	$M_{MAX}/M_A$	$FW_{MIN}$ [mm]	$SL_{MIN}$ [mm]
180	8	2	38.5	0.33	77.9	19.8	485	2.7	252	245
180	8	2	31.35	0.41	95.7	16.1	395	3.0	252	245
180	8	2	26.94	0.47	111.4	13.8	339	3.0	252	245
180	8	2	20.27	0.63	148.0	10.4	255	3.0	252	245
180	8	2	14.44	0.89	207.8	7.4	182	3.0	252	245
180	8	2	11.23	1.14	267.1	5.8	141	3.0	252	245
180	8	1	8.25	1.55	363.6	4.5	110	3.0	252	245
180	8	1	4.71	2.72	636.9	2.6	63	3.0	252	245
235	8	2	38.5	0.33	77.9	27.7	680	1.9	282	275
235	8	2	31.35	0.41	95.7	22.6	554	3.0	282	275
235	8	2	26.94	0.47	111.4	19.4	476	3.0	282	275
235	8	2	20.27	0.63	148.0	14.6	358	3.0	282	275
235	8	2	14.44	0.89	207.8	10.4	255	3.0	282	275
235	8	2	11.23	1.14	267.1	8.1	198	3.0	282	275
235	8	1	8.25	1.55	363.6	6.3	154	3.0	282	275
235	8	1	4.71	2.72	636.9	3.6	88	3.0	282	275

$P_N$  = Rated power  
 $n_p$  = Number of poles  
 gs = Gear stages  
 i = Speed ratio  
 v = Speed  
 $n_A$  = Shell rated speed

$M_A$  = Drum motor rated torque  
 $F_N$  = Drum motor rated belt pull  
 $M_{MAX}/M_A$  = Ratio of max. acceleration torque to rated torque  
 $FW_{MIN}$  = Minimum drum width  
 $SL_{MIN}$  = Minimum shell length

# DRUM MOTOR DM SERIES DM 0080

## Electrical data for oil-free synchronous motors

$P_N$ [W]	$n_p$	$U_N$ [V]	$I_N$ [A]	$I_0$ [A]	$I_{MAX}$ [A]	$f_N$ [Hz]	$\eta$	$n_N$ [1/min]	$J_R$ [kgcm <sup>2</sup> ]	$M_N$ [Nm]	$M_0$ [Nm]	$M_{MAX}$ [Nm]	$R_M$ [Ω]	$L_{SD}$ [mH]	$L_{SQ}$ [mH]	$k_e$ [V/krpm]	$T_e$ [ms]	$k_{TN}$ [Nm/A]	$U_{SH}$ [VDC]
80	8	230	0.45	0.45	1.34	200	0.85	3000	0.14	0.25	0.25	0.76	21.62	45.6	53.7	41.57	4.97	0.57	25
80	8	400	0.26	0.26	0.78	200	0.83	3000	0.14	0.25	0.25	0.76	62.54	130.7	138.0	72.23	4.41	0.98	36
110	8	230	0.48	0.48	1.44	200	0.86	3000	0.28	0.35	0.35	1.05	10.20	27.8	29.3	47.46	5.75	0.73	19
110	8	400	0.29	0.29	0.86	200	0.87	3000	0.28	0.35	0.35	1.05	29.06	81.9	94.1	83.09	6.48	1.22	32
180	8	230	1.97	1.97	2.91	200	0.87	3000	0.42	0.57	0.57	1.72	5.66	16.3	19.4	45.81	6.86	0.59	19
180	8	400	0.56	0.56	1.69	200	0.86	3000	0.42	0.57	0.57	1.72	17.60	49.8	59.0	80.80	6.70	1.02	33
235	8	230	1.30	1.30	3.90	200	0.92	3000	0.60	0.75	0.75	2.25	3.89	10.2	11.8	38.45	6.06	0.58	2.53
235	8	400	0.75	0.75	2.25	200	0.92	3000	0.60	0.75	0.75	2.25	9.20	24.1	27.6	66.60	6.00	1.00	3.45

$P_N$	= Rated power	$M_N$	= Rated torque of rotor
$n_p$	= Number of poles	$M_0$	= Standstill torque
$U_N$	= Rated voltage	$M_{MAX}$	= Maximum torque
$I_N$	= Rated current	$R_M$	= Phase to phase resistance
$I_0$	= Standstill current	$L_{SD}$	= d-axis inductance
$I_{MAX}$	= Maximum current	$L_{SQ}$	= q-axis inductance
$f_N$	= Rated frequency	$k_e$	= EMF (mutual induction voltage constant)
$\eta$	= Efficiency	$T_e$	= Electrical time constant
$n_N$	= Rated torque of rotor	$k_{TN}$	= Torque constant
$J_R$	= Rotor moment of inertia	$U_{SH}$	= Heating voltage

# DRUM MOTOR

## DM SERIES

### DM 0080

#### Mechanical data for 3-phase asynchronous motor with steel gear

$P_N$ [W]	$n_p$	gs	i	v [m/s]	$n_A$ [min <sup>-1</sup> ]	$M_A$ [Nm]	$F_N$ [N]	$FW_{MIN}$ [mm]	$SL_{MIN}$ [mm]
40	4	3	164.23	0.03	7.8	42.4	1040	219	212
40	4	3	119.83	0.05	10.7	30.9	759	219	212
40	4	3	103.89	0.05	12.3	26.8	658	219	212
40	4	3	85.34	0.06	15.0	22.0	541	219	212
40	4	2	62.70	0.09	20.4	16.9	416	200	193
40	4	2	53.63	0.10	23.8	14.5	356	200	193
40	4	2	42.28	0.13	30.2	11.4	281	200	193
40	4	2	38.50	0.14	33.2	10.4	256	200	193
40	4	2	31.35	0.17	40.8	8.5	208	200	193
40	4	2	26.94	0.20	47.4	7.3	179	200	193
40	4	2	20.27	0.27	63.0	5.5	135	200	193
75	2	3	164.23	0.07	16.2	38.1	936	219	212
75	2	3	119.83	0.10	22.2	27.8	683	219	212
75	2	3	103.89	0.11	25.6	24.1	592	219	212
75	2	3	85.34	0.13	31.2	19.8	486	219	212
75	2	2	62.70	0.18	42.4	15.2	374	200	193
75	2	2	53.63	0.21	49.6	13.0	320	200	193
75	2	2	42.28	0.27	62.9	10.3	252	200	193
75	2	2	38.50	0.30	69.1	9.4	230	200	193
75	2	2	31.35	0.36	84.8	7.6	187	200	193
75	2	2	26.94	0.42	98.7	6.5	161	200	193
75	2	2	20.27	0.56	131.2	4.9	121	200	193
75	2	2	14.44	0.79	184.1	3.5	86	200	193
75	2	2	11.23	1.01	236.8	2.7	67	200	193

# DRUM MOTOR DM SERIES DM 0080

$P_N$ [W]	$n_p$	gs	i	v [m/s]	$n_A$ [min <sup>-1</sup> ]	$M_A$ [Nm]	$F_N$ [N]	$FW_{MIN}$ [mm]	$SL_{MIN}$ [mm]
80	4	3	119.83	0.05	10.9	59.8	1467	269	262
80	4	3	103.89	0.05	12.6	51.8	1272	269	262
80	4	3	85.34	0.07	15.3	42.6	1045	269	262
80	4	2	62.70	0.09	20.9	32.7	804	250	243
80	4	2	53.63	0.10	24.4	28.0	687	250	243
80	4	2	42.28	0.13	30.9	22.1	542	250	243
80	4	2	38.50	0.15	34.0	20.1	494	250	243
80	4	2	31.35	0.18	41.7	16.4	402	250	243
80	4	2	26.94	0.21	48.6	14.1	345	250	243
80	4	2	20.27	0.28	64.5	10.6	260	250	243
80	4	2	14.44	0.39	90.6	7.5	185	250	243
80	4	2	11.23	0.50	116.5	5.9	144	250	243
80	4	1	8.25	0.68	158.5	4.5	112	250	243
80	4	1	4.71	1.18	277.7	2.6	64	250	243
140	2	3	119.83	0.10	23.0	50.5	1239	269	262
140	2	3	103.89	0.11	26.5	43.8	1074	269	262
140	2	3	85.34	0.14	32.3	36.0	883	269	262
140	2	2	62.70	0.19	43.9	27.7	679	250	243
140	2	2	53.63	0.22	51.3	23.7	580	250	243
140	2	2	42.28	0.28	65.1	18.6	458	250	243
140	2	2	38.50	0.31	71.5	17.0	417	250	243
140	2	2	31.35	0.38	87.8	13.8	339	250	243
140	2	2	26.94	0.44	102.2	11.9	292	250	243
140	2	2	20.27	0.58	135.8	8.9	219	250	243
140	2	2	14.44	0.81	190.7	6.4	156	250	243
140	2	2	11.23	1.05	245.1	5.0	122	250	243
140	2	1	8.25	1.42	333.7	3.8	94	250	243
140	2	1	4.71	2.49	584.5	2.2	54	250	243

$P_N$  = Rated power  
 $n_p$  = Number of poles  
 gs = Gear stages  
 i = Speed ratio  
 v = Speed

$n_A$  = Shell rated speed  
 $M_A$  = Drum motor rated torque  
 $F_N$  = Drum motor rated belt pull  
 $FW_{MIN}$  = Minimum drum width  
 $SL_{MIN}$  = Minimum shell length

DL series

DM series

DP series

Application notes

# DRUM MOTOR

## DM SERIES

### DM 0080

#### Mechanical data for 3-phase asynchronous motor with technopolymer gear

$P_N$ [W]	$n_p$	gs	i	v [m/s]	$n_A$ [min <sup>-1</sup> ]	$M_A$ [Nm]	$F_N$ [N]	$FW_{MIN}$ [mm]	$SL_{MIN}$ [mm]
40	4	3	78.55	0.07	16.3	20.3	498	239	232
40	4	3	71.56	0.08	17.9	18.5	454	239	232
40	4	3	63.51	0.09	20.1	16.4	403	239	232
40	4	3	52.92	0.10	24.1	13.7	336	239	232
40	4	3	48.79	0.11	26.2	12.6	309	239	232
40	4	3	43.3	0.13	29.5	11.2	275	239	232
40	4	2	19.2	0.28	66.6	5.2	128	239	232
40	4	2	16	0.34	79.9	4.3	106	239	232
40	4	2	13.09	0.42	97.6	3.5	87	239	232
75	2	3	78.55	0.14	33.9	18.2	448	239	232
75	2	3	71.56	0.16	37.2	16.6	408	239	232
75	2	3	63.51	0.18	41.9	14.7	362	239	232
75	2	3	52.92	0.21	50.2	12.3	302	239	232
75	2	3	48.79	0.23	54.5	11.3	278	239	232
75	2	3	43.3	0.26	61.4	10.1	247	239	232
75	2	2	19.2	0.59	138.5	4.7	114	239	232
75	2	2	16	0.71	166.2	3.9	95	239	232
75	2	2	13.09	0.87	203.1	3.2	78	239	232

$P_N$	= Rated power	$n_A$	= Shell rated speed
$n_p$	= Number of poles	$M_A$	= Drum motor rated torque
gs	= Gear stages	$F_N$	= Drum motor rated belt pull
i	= Speed ratio	$FW_{MIN}$	= Minimum drum width
v	= Speed	$SL_{MIN}$	= Minimum shell length

# DRUM MOTOR DM SERIES DM 0080

## Electrical data for 3-phase asynchronous motor

$P_N$ [W]	$n_p$	$n_N$ [min <sup>-1</sup> ]	$f_N$ [Hz]	$U_N$ [V]	$I_N$ [A]	$\cos\varphi$	$\eta$	$J_R$ [kgcm <sup>2</sup> ]	$I_s/I_N$	$M_s/M_N$	$M_B/M_N$	$M_P/M_N$	$M_N$ [Nm]	$R_M$ [Ω]	$U_{SH\Delta}$ [V]	$U_{SHY}$ [V]
40	4	1319	50	230	0.34	0.71	0.42	0.67	1.93	1.31	1.51	1.31	0.29	294.5	35.4	–
40	4	1319	50	400	0.20	0.71	0.42	0.67	1.93	1.31	1.51	1.31	0.29	294.5	–	61.4
75	2	2730	50	230	0.39	0.83	0.58	0.67	3.04	1.48	1.70	1.48	0.26	164.4	25.9	–
75	2	2730	50	400	0.22	0.83	0.58	0.67	3.04	1.48	1.70	1.48	0.26	164.4	–	44.8
80	4	1331	50	230	0.58	0.67	0.51	1.25	2.20	1.46	1.65	1.46	0.57	132.5	26.4	–
80	4	1331	50	400	0.34	0.67	0.51	1.25	2.20	1.46	1.65	1.46	0.57	132.5	–	45.8
140	2	2796	50	230	0.65	0.79	0.67	1.25	3.86	1.88	2.03	1.88	0.48	72.7	19.0	–
140	2	2796	50	400	0.38	0.79	0.67	1.25	3.86	1.88	2.03	1.88	0.48	72.7	–	32.9

$P_N$	= Rated power	$I_s/I_N$	= Ratio of startup current – rated current
$n_p$	= Number of poles	$M_s/M_N$	= Ratio of startup torque – rated torque
$n_N$	= Rated speed of rotor	$M_B/M_N$	= Ratio of pull-out torque – rated torque
$f_N$	= Rated frequency	$M_P/M_N$	= Ratio of pull-up torque – rated torque
$U_N$	= Rated voltage	$M_N$	= Rated torque of rotor
$I_N$	= Rated current	$R_M$	= Branch resistance
$\cos\varphi$	= Power factor	$U_{SH\Delta}$	= Heater voltage in delta connection
$\eta$	= Efficiency	$U_{SHY}$	= Heater voltage in star connection
$J_R$	= Rotor moment of inertia		

# DRUM MOTOR

## DM SERIES

### DM 0080

#### Mechanical data for 1-phase asynchronous motor with steel gear

$P_N$ [W]	$n_p$	gs	i	v [m/s]	$n_A$ [1/min]	$M_A$ [Nm]	$F_N$ [N]	$FW_{MIN}$ [mm]	$SL_{MIN}$ [mm]
25	4	3	119.83	0.05	11.0	18.5	455	269	262
25	4	3	103.89	0.05	12.7	16.1	395	269	262
25	4	3	85.34	0.07	15.5	13.2	324	269	262
25	4	2	62.7	0.09	21.1	10.2	249	250	243
25	4	2	53.63	0.11	24.6	8.7	213	250	243
25	4	2	42.28	0.13	31.2	6.8	168	250	243
25	4	2	38.5	0.15	34.3	6.2	153	250	243
25	4	2	31.35	0.18	42.1	5.1	125	250	243
25	4	2	26.94	0.21	49.0	4.4	107	250	243
25	4	2	20.27	0.28	65.1	3.3	81	250	243
75	2	3	119.83	0.10	22.9	26.8	658	269	262
75	2	3	103.89	0.11	26.5	23.2	570	269	262
75	2	3	85.34	0.14	32.2	19.1	468	269	262
75	2	2	62.7	0.19	43.9	14.7	360	250	243
75	2	2	53.63	0.22	51.3	12.5	308	250	243
75	2	2	42.28	0.28	65.0	9.9	243	250	243
75	2	2	38.5	0.31	71.4	9.0	221	250	243
75	2	2	31.35	0.37	87.7	7.3	180	250	243
75	2	2	26.94	0.44	102.1	6.3	155	250	243
75	2	2	20.27	0.58	135.7	4.7	116	250	243
75	2	2	14.44	0.81	190.4	3.4	83	250	243
75	2	2	11.23	1.04	244.9	2.6	64	250	243



# DRUM MOTOR DM SERIES DM 0080

$P_N$ [W]	$n_p$	gs	i	v [m/s]	$n_A$ [1/min]	$M_A$ [Nm]	$F_N$ [N]	$FW_{MIN}$ [mm]	$SL_{MIN}$ [mm]
85	2	3	119.83	0.10	22.9	30.9	759	269	262
85	2	3	103.89	0.11	26.5	26.8	658	269	262
85	2	3	85.34	0.14	32.2	22.0	540	269	262
85	2	2	62.7	0.19	43.9	16.9	415	250	243
85	2	2	53.63	0.22	51.3	14.5	355	250	243
85	2	2	42.28	0.28	65.0	11.4	280	250	243
85	2	2	38.5	0.31	71.4	10.4	255	250	243
85	2	2	31.35	0.37	87.7	8.5	208	250	243
85	2	2	26.94	0.44	102.1	7.3	178	250	243
85	2	2	20.27	0.58	135.7	5.5	134	250	243
85	2	2	14.44	0.81	190.4	3.9	96	250	243
85	2	2	11.23	1.04	244.9	3.0	74	250	243
110	2	3	119.83	0.10	23.0	39.2	961	269	262
110	2	3	103.89	0.11	26.5	34.0	833	269	262
110	2	3	85.34	0.14	32.2	27.9	684	269	262
110	2	2	62.7	0.19	43.9	21.4	526	250	243
110	2	2	53.63	0.22	51.3	18.3	450	250	243
110	2	2	42.28	0.28	65.0	14.5	355	250	243
110	2	2	38.5	0.31	71.4	13.2	323	250	243
110	2	2	31.35	0.37	87.7	10.7	263	250	243
110	2	2	26.94	0.44	102.1	9.2	226	250	243
110	2	2	20.27	0.58	135.7	6.9	170	250	243
110	2	2	14.44	0.81	190.5	4.9	121	250	243
110	2	2	11.23	1.05	244.9	3.8	94	250	243

$P_N$  = Rated power  
 $n_p$  = Number of poles  
 gs = Gear stages  
 i = Speed ratio  
 v = Speed  
 $n_A$  = Shell rated speed

$M_A$  = Drum motor rated torque  
 $F_N$  = Drum motor rated belt pull  
 $M_{MAX}/M_A$  = Ratio of max. acceleration torque to rated torque  
 $FW_{MIN}$  = Minimum drum width  
 $SL_{MIN}$  = Minimum shell length

# DRUM MOTOR

## DM SERIES

### DM 0080

#### Mechanical data for 1-phase asynchronous motor with technopolymer gear

$P_N$ [W]	$n_p$	gs	i	v [m/s]	$n_A$ [1/min]	$M_A$ [Nm]	$F_N$ [N]	$FW_{MIN}$ [mm]	$SL_{MIN}$ [mm]
25	4	3	115.2	0.05	11.5	17.8	436	287	280
25	4	3	96	0.06	13.8	14.8	364	287	280
25	4	3	78.55	0.07	16.8	12.1	297	287	280
25	4	3	71.56	0.08	18.4	11	271	287	280
75	2	3	96	0.12	28.6	21.4	525	287	280
75	2	3	78.55	0.15	35	17.5	430	287	280
75	2	3	71.56	0.16	38.4	16	391	287	280
75	2	3	63.51	0.19	43.3	14.2	347	287	280
85	2	3	78.55	0.15	35	20.2	496	287	280
85	2	3	71.56	0.16	38.4	18.4	452	287	280
85	2	3	63.51	0.19	43.3	16.3	401	287	280
110	2	3	63.51	0.19	43.3	20.7	508	287	280
110	2	3	52.92	0.22	52	17.2	423	287	280
110	2	3	48.79	0.24	56.4	15.9	390	287	280
110	2	3	43.3	0.27	63.5	14.1	346	287	280
110	2	2	19.2	0.61	143.2	6.6	162	287	280
110	2	2	16	0.73	171.9	5.5	135	287	280
110	2	2	13.09	0.90	210.1	4.5	110	287	280

$P_N$  = Rated power  
 $n_p$  = Number of poles  
 gs = Gear stages  
 i = Speed ratio  
 v = Speed  
 $n_A$  = Shell rated speed

$M_A$  = Drum motor rated torque  
 $F_N$  = Drum motor rated belt pull  
 $M_{MAX}/M_A$  = Ratio of max. acceleration torque to rated torque  
 $FW_{MIN}$  = Minimum drum width  
 $SL_{MIN}$  = Minimum shell length

# DRUM MOTOR DM SERIES DM 0080

## Electrical data for 1-phase asynchronous motor

$P_N$ [W]	$n_p$	$n_N$ [min <sup>-1</sup> ]	$f_N$ [Hz]	$U_N$ [V]	$I_N$ [A]	$\cos\varphi$	$\eta$	$J_R$ [kgcm <sup>2</sup> ]	$I_s/I_N$	$M_s/M_N$	$M_B/M_N$	$M_P/M_N$	$M_N$ [Nm]	$R_M$ [Ω]	$U_{SH \sim}$ [V DC]	$C_R$ [μF]
25	4	1320	50	230	0.39	1	0.28	1.3	2.19	1.11	1.37	1.11	0.18	150	44	3
50	2	2750	50	230	0.54	1	0.4	0.9	3.08	0.94	1.71	0.94	0.17	82	33	3
75	2	2750	50	230	0.68	1	0.48	1	3.19	0.74	1.37	0.74	0.26	66	34	4
85	2	2750	50	230	0.73	0.98	0.53	1.3	5.24	0.93	1.6	0.93	0.3	52	28	6
110	2	2750	50	230	0.94	1	0.51	1.3	1.97	0.73	1.15	0.73	0.38	51	36	8

$P_N$	= Rated power	$I_s/I_N$	= Ratio of startup current – rated current
$n_p$	= Number of poles	$M_s/M_N$	= Ratio of startup torque – rated torque
$n_N$	= Rated speed of rotor	$M_B/M_N$	= Ratio of pull-out torque – rated torque
$f_N$	= Rated frequency	$M_P/M_N$	= Ratio of pull-up torque – rated torque
$U_N$	= Rated voltage	$M_N$	= Rated torque of rotor
$I_N$	= Rated current	$R_M$	= Branch resistance
$\cos\varphi$	= Power factor	$U_{SH \sim}$	= Heater voltage for DC units
$\eta$	= Efficiency	$C_R$	= Capacitor size
$J_R$	= Rotor moment of inertia		

# DRUM MOTOR

## DM SERIES

### DM 0080

#### Belt tension diagrams

##### Belt tension depending on drum width

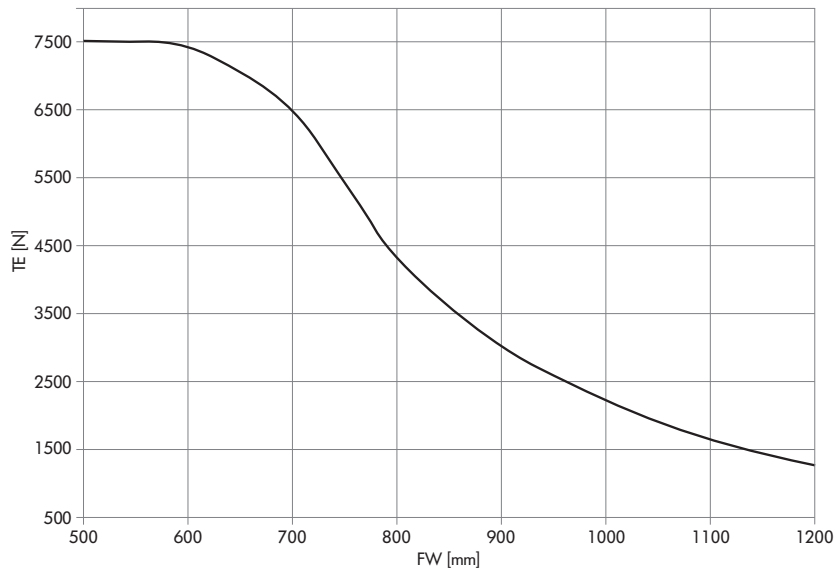

##### Belt tension depending on rated speed of shell

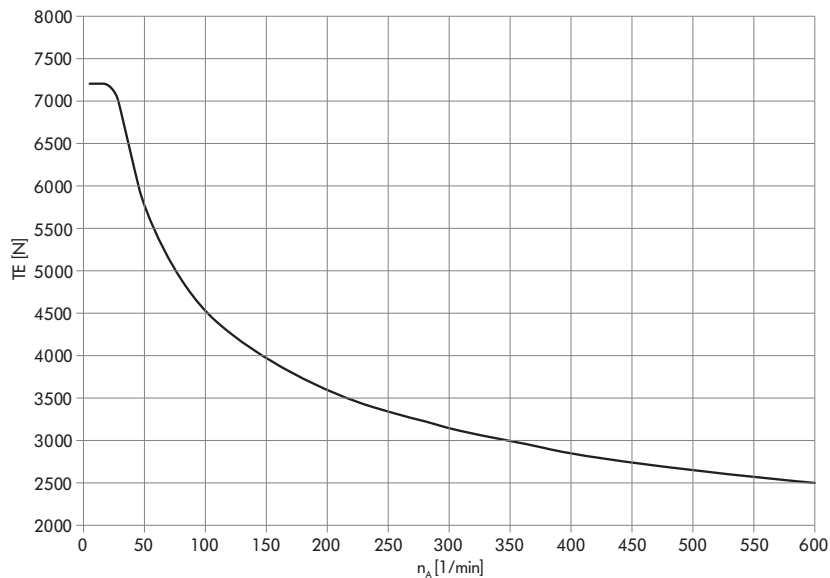

**Note:** The correct value for the maximum permissible belt tension is determined from the speed of the drum motor. When selecting the motor, also check whether the maximum permissible TE value fits the desired drum width (FW). The belt tension diagrams apply only to standard shafts.

- TE = Belt tension
- $n_A$  = Shell rated speed
- FW = Drum width

# DRUM MOTOR DM SERIES DM 0080

## Dimensions

### Drum motor

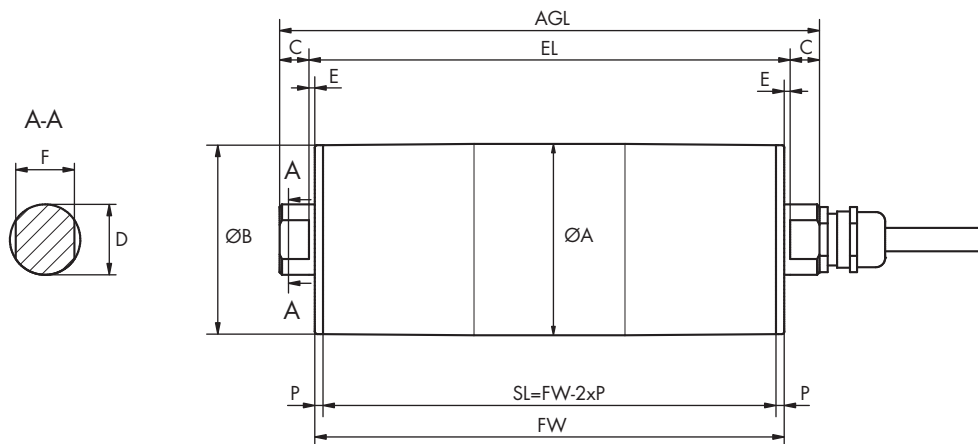

Type		A [mm]	B [mm]	C [mm]	D [mm]	S [mm]	F [mm]	P [mm]	SL [mm]	EL [mm]	AGL [mm]
<b>DM 0080 crowned</b>	Standard	81.5	80.5	12.5	30	2.5	25	3.5	FW - 7	FW + 5	FW + 30
	Optional	81.5	80.5	12.5	25	2.5	20	3.5	FW - 7	FW + 5	FW + 30
	Optional	81.5	80.5	12.5	17	2.5	13.5	3.5	FW - 7	FW + 5	FW + 30
<b>DM 0080 cylindrical</b>	Standard	81	81	12.5	30	2.5	25	3.5	FW - 7	FW + 5	FW + 30
	Optional	81	81	12.5	25	2.5	20	3.5	FW - 7	FW + 5	FW + 30
	Optional	81	81	12.5	17	2.5	13.5	3.5	FW - 7	FW + 5	FW + 30
<b>DM 0080 cylindrical + key</b>	Standard	81.7	81.7	12.5	30	2.5	25	3.5	FW - 7	FW + 5	FW + 30
	Optional	81.7	81.7	12.5	25	2.5	20	3.5	FW - 7	FW + 5	FW + 30
	Optional	81.7	81.7	12.5	17	2.5	13.5	3.5	FW - 7	FW + 5	FW + 30

# DRUM MOTOR

## DM SERIES

### DM 0113



Practice-oriented, scalable and thought out in detail: The new drum motor DM 0113 makes it easy to build a completely individual conveyor system and is dimensioned for the higher requirements of permissible belt tension now demanded from industry and belt manufacturers alike.

With a broader speed spectrum, the DM 0113 covers all possible applications. The clever plug-and-play connection significantly simplifies the installation. Each motor is approved, tested, and modularized so that it can be produced and delivered around the world in the shortest amount of time.

The modular design of the DM 0113 allows a free combination of individual module groups, such as shaft, end housing, shell or steel gear, asynchronous or synchronous motor winding, to perfectly meet the requirements of an application. In addition, various options, such as encoder, brake, backstop, rubber laggings, etc., as well as different accessories are available.

With the platform concept of the DM 0113, it is possible to cover all internal logistics applications in the food processing sector, as well as in industry, distribution and airports.



## Technical data

	Asynchronous squirrel cage motor	AC synchronous permanent magnet motor
<b>Insulation class of motor windings</b>	Class F, IEC 34 (VDE 0530)	Class F, IEC 34 (VDE 0530)
<b>Voltage</b>	230/400 V $\pm 5\%$ (IEC 34/38) Most of the common international voltages and frequencies are available upon request	230 or 400 V
<b>Frequency</b>	50 Hz	200 Hz
<b>Shaft seal, internal</b>	NBR	NBR
<b>Protection rate Motor*</b>	IP69K	IP69K
<b>Thermal controller</b>	Bi-metal switch	Bi-metal switch
<b>Operating mode</b>	S1	S1
<b>Ambient temperature, 3-phase motor</b>	+2 to +40 °C Low temperature ranges on request	+2 to +40 °C Low temperature ranges on request
<b>Ambient temperature, 3-phase motor for applications with form-fit belts or no belt</b>	+2 to +25 °C	+2 to +40 °C

\* The protection rate of the cable connector may deviate.

## Design variants and accessories

<b>Lagging</b>	Lagging for friction drive belts Lagging for modular plastic belts Lagging for positive drive solid homogeneous belts
<b>Sprockets</b>	Sprockets
<b>Options</b>	Backstop Electromagnetic holding brake and rectifier* Encoder* Balancing Plug connection*
<b>Oils</b>	Food-grade oils (EU, FDA, NSF H1)
<b>Certificate</b>	cULus safety certificates
<b>Accessories</b>	Idler pulleys; conveyor rollers; mounting brackets; cables; inverters

A combination of encoder and safety holding brake is not possible. In addition, the use of a backstop with a synchronous motor is technically not meaningful.

\* Depending on the option, the motor extends by 50 – 70 mm.

# DRUM MOTOR

## DM SERIES

### DM 0113

#### Material variants

The following components can be selected for the drum motor and the electrical connection. The combination of components depends on the material used.

Component	Version	Aluminum	Mild steel	Stainless steel	Brass/nickel	Technopolymer
<b>Shell</b>	Crowned		●	●		
	Cylindrical		●	●		
	Cylindrical + key for sprockets		●	●		
<b>End housing</b>	Standard	●		●		
<b>Shaft</b>	Standard			●		
	Cross-drilled thread			●		
<b>Gear boxes</b>	Planetary gear box		●			
<b>Electrical connector</b>	Straight connector			●	●	●
	Straight hygienic connector			●		
	Elbow connector			●		●
	Terminal box	●		●		●
	Straight plug connection			●		
	90° plug connection			●		
	90° hygienic connector			●		
<b>Motor winding</b>	Asynchronous motor					
	Synchronous motor					
<b>External seal</b>	PTFE					



# DRUM MOTOR DM SERIES DM 0113

## Motor variants

### Mechanical data for synchronous motors with steel gear

$P_N$ [W]	$n_p$	gs	i	v [m/s]	$n_A$ [min <sup>-1</sup> ]	$M_A$ [Nm]	$F_N$ [N]	$M_{MAX}/M_A$	$FW_{MIN}$ [mm]	$SL_{MIN}$ [mm]
300	8	3	120	0.15	25.0	98.8	1,740	1.6	228	221
300	8	3	100	0.18	30.0	82.3	1,450	2	228	221
300	8	3	80	0.22	37.5	65.8	1,160	2.5	228	221
300	8	2	63	0.28	47.6	54.6	962	3	208	201
300	8	2	45	0.40	66.7	39.0	687	3	208	201
300	8	2	36	0.49	83.3	31.2	550	3	208	201
300	8	2	30	0.59	100.0	26.0	458	3	208	201
300	8	2	24	0.74	125.0	20.8	366	3	208	201
300	8	2	20	0.89	150.0	17.3	305	3	208	201
300	8	2	16	1.11	187.5	13.9	244	3	208	201
300	8	2	12	1.48	250.0	10.4	183	3	208	201
300	8	1	9	1.98	333.3	8.2	145	3	208	201
300	8	1	6	2.97	500.0	5.5	96	3	208	201
700	8	2	63	0.28	47.6	126.8	2,234	1.3	258	251
700	8	2	45	0.40	66.7	90.6	1,596	1.8	258	251
700	8	2	36	0.49	83.3	72.5	1,277	1.4	258	251
700	8	2	30	0.59	100.0	60.4	1,064	1.7	258	251
700	8	2	24	0.74	125.0	48.3	851	2	258	251
700	8	2	20	0.89	150.0	40.3	709	2.5	258	251
700	8	2	16	1.11	187.5	32.2	567	3	258	251
700	8	2	12	1.48	250.0	24.2	426	3	258	251
700	8	1	9	1.98	333.3	19.1	336	3	258	251
700	8	1	6	2.97	500.0	12.7	224	3	258	251

DL series

DM series

DP series

Application notes

# DRUM MOTOR

## DM SERIES

### DM 0113



$P_N$ [W]	$n_p$	gs	i	v [m/s]	$n_A$ [min <sup>-1</sup> ]	$M_A$ [Nm]	$F_N$ [N]	$M_{MAX}/M_A$	$FW_{MIN}$ [mm]	$SL_{MIN}$ [mm]
1100	8	2	36	0.49	83.3	113.7	2,004	1.4	288	281
1100	8	2	30	0.59	100.0	94.8	1,670	1.6	288	281
1100	8	2	24	0.74	125.0	75.8	1,336	2	288	281
1100	8	2	20	0.89	150.0	63.2	1,113	2.5	288	281
1100	8	2	16	1.11	187.5	50.5	891	3	288	281
1100	8	2	12	1.48	250.0	37.9	668	3	288	281
1100	8	1	9	1.98	333.3	29.9	527	3	288	281
1100	8	1	6	2.97	500.0	20.0	352	3	288	281

$P_N$	= Rated power	$M_A$	= Drum motor rated torque
$n_p$	= Number of poles	$F_N$	= Drum motor rated belt pull
gs	= Gear stages	$M_{MAX}/M_A$	= Ratio of max. acceleration torque to rated torque
i	= Speed ratio	$FW_{MIN}$	= Minimum drum width
v	= Speed	$SL_{MIN}$	= Minimum shell length
$n_A$	= Shell rated speed		

#### Electrical data for synchronous motors

$P_N$ [W]	$n_p$	$U_N$ [V]	$I_N$ [A]	$I_0$ [A]	$I_{MAX}$ [A]	$f_N$ [Hz]	$\eta$	$n_N$ [1/min]	$J_R$ [kgcm <sup>2</sup> ]	$M_N$ [Nm]	$M_0$ [Nm]	$M_{MAX}$ [Nm]	$R_M$ [Ω]	$L_{SD}$ [mH]	$L_{SQ}$ [mH]	$k_e$ [V/krpm]	$T_e$ [ms]	$k_{TN}$ [Nm/A]	$U_{SH}$ [V]
300	8	230	1.25	1.25	3.76	200	0.85	3000	1.8	0.96	0.96	2.88	11.47	5.5	10.2	50.34	3.57	0.76	10.78
300	8	400	0.72	0.72	2.17	200	0.85	3000	1.8	0.96	0.96	2.88	34.40	16.5	30.7	87.20	3.57	1.32	18.68
700	8	230	2.67	2.67	8.00	200	0.89	3000	5.4	2.23	2.23	6.69	2.63	2.5	4.4	55.48	6.73	0.84	5.27
700	8	400	1.54	1.54	4.62	200	0.89	3000	5.4	2.23	2.23	6.69	7.90	7.4	13.3	96.10	6.73	1.45	9.12
1100	8	230	3.97	3.97	11.90	200	0.92	3000	7.2	3.50	3.50	10.49	1.88	1.9	3.2	56.52	6.78	0.88	5.61
1100	8	400	2.29	2.29	6.87	200	0.92	3000	7.2	3.50	3.50	10.49	5.66	5.8	9.6	97.90	6.78	1.53	9.72

$P_N$	= Rated power	$M_N$	= Rated torque of rotor
$n_p$	= Number of poles	$M_0$	= Standstill torque
$U_N$	= Rated voltage	$M_{MAX}$	= Maximum torque
$I_N$	= Rated current	$R_M$	= Phase to phase resistance
$I_0$	= Standstill current	$L_{SD}$	= d-axis inductance
$I_{MAX}$	= Maximum current	$L_{SQ}$	= q-axis inductance
$f_N$	= Rated frequency	$k_e$	= EMF (mutual induction voltage constant)
$\eta$	= Efficiency	$T_e$	= Electrical time constant
$n_N$	= Rated torque of rotor	$k_{TN}$	= Torque constant
$J_R$	= Rotor moment of inertia	$U_{SH}$	= Heating voltage

# DRUM MOTOR DM SERIES DM 0113

## Mechanical data for synchronous motors with oil-free steel gear

$P_N$ [W]	$n_p$	$g_s$	$i$	$v$ [m/s]	$n_A$ [min <sup>-1</sup> ]	$M_A$ [Nm]	$F_N$ [N]	$M_{MAX}/M_A$	$FW_{MIN}$ [mm]	$SL_{MIN}$ [mm]
190	8	3	120	0.15	25.0	62.2	1,096	1.6	228	221
190	8	3	100	0.18	30.0	51.9	914	2	228	221
190	8	3	80	0.22	37.5	41.5	731	2.5	228	221
190	8	2	63	0.28	47.6	34.4	606	3	208	201
190	8	2	45	0.40	66.7	24.6	433	3	208	201
190	8	2	36	0.49	83.3	19.6	346	3	208	201
190	8	2	30	0.59	100.0	16.4	289	3	208	201
190	8	2	24	0.74	125.0	13.1	231	3	208	201
190	8	2	20	0.89	150.0	10.9	192	3	208	201
190	8	2	16	1.11	187.5	8.7	154	3	208	201
190	8	2	12	1.48	250.0	6.5	115	3	208	201
190	8	1	9	1.98	333.3	5.2	91	3	208	201
190	8	1	6	2.97	500.0	3.4	61	3	208	201
440	8	2	63	0.28	47.6	79.6	1,403	1.3	258	251
440	8	2	45	0.40	66.7	56.9	1,002	1.8	258	251
440	8	2	36	0.49	83.3	45.5	802	2.2	258	251
440	8	2	30	0.59	100.0	37.9	668	2.6	258	251
440	8	2	24	0.74	125.0	30.3	534	3	258	251
440	8	2	20	0.89	150.0	25.3	445	3	258	251
440	8	2	16	1.11	187.5	20.2	356	3	258	251
440	8	2	12	1.48	250.0	15.2	267	3	258	251
440	8	1	9	1.98	333.3	12.0	211	3	258	251
440	8	1	6	2.97	500.0	8.0	141	3	258	251

DL series

DM series

DP series

Application notes

# DRUM MOTOR

## DM SERIES

### DM 0113



$P_N$ [W]	$n_p$	gs	i	v [m/s]	$n_A$ [min <sup>-1</sup> ]	$M_A$ [Nm]	$F_N$ [N]	$M_{MAX}/M_A$	$FW_{MIN}$ [mm]	$SL_{MIN}$ [mm]
700	8	2	36	0.49	83.3	72.5	1,277	2.2	288	281
700	8	2	30	0.59	100.0	60.4	1,064	2.6	288	281
700	8	2	24	0.74	125.0	48.3	851	3	288	281
700	8	2	20	0.89	150.0	40.3	709	3	288	281
700	8	2	16	1.11	187.5	32.2	567	3	288	281
700	8	2	12	1.48	250.0	24.2	426	3	288	281
700	8	1	9	1.98	333.3	19.1	336	3	288	281
700	8	1	6	2.97	500.0	12.7	224	3	288	281

$P_N$	= Rated power	$M_A$	= Drum motor rated torque
$n_p$	= Number of poles	$F_N$	= Drum motor rated belt pull
gs	= Gear stages	$M_{MAX}/M_A$	= Ratio of max. acceleration torque to rated torque
i	= Speed ratio	$FW_{MIN}$	= Minimum drum width
v	= Speed	$SL_{MIN}$	= Minimum shell length
$n_A$	= Shell rated speed		

#### Electrical data for oil-free synchronous motors

$P_N$ [W]	$n_p$	$U_N$ [V]	$I_N$ [A]	$I_0$ [A]	$I_{MAX}$ [A]	$f_N$ [Hz]	$\eta$	$n_N$ [1/min]	$J_R$ [kgcm <sup>2</sup> ]	$M_N$ [Nm]	$M_0$ [Nm]	$M_{MAX}$ [Nm]	$R_M$ [Ω]	$L_{SD}$ [mH]	$L_{SQ}$ [mH]	$k_e$ [V/krpm]	$T_e$ [ms]	$k_{TN}$ [Nm/A]	$U_{SH}$ [V]
190	8	230	0.80	0.80	2.39	200	0.88	3000	1.8	0.60	0.60	1.81	11.47	5.5	10.2	50.34	3.57	0.76	6.85
190	8	400	0.46	0.46	1.38	200	0.88	3000	1.8	0.60	0.60	1.81	34.40	16.5	30.7	87.20	3.57	1.31	11.87
440	8	230	1.77	1.77	5.30	200	0.87	3000	5.4	1.40	1.40	4.20	2.49	2.5	4.4	55.48	7.13	0.79	3.29
440	8	400	1.02	1.02	3.06	200	0.87	3000	5.4	1.40	1.40	4.20	7.46	7.4	13.3	96.10	7.13	1.37	5.71
700	8	230	2.55	2.55	7.64	200	0.94	3000	7.2	2.23	2.23	6.69	1.88	1.9	3.2	56.52	6.78	0.88	3.60
700	8	400	1.47	1.47	4.41	200	0.94	3000	7.2	2.23	2.23	6.69	5.66	5.8	9.6	97.90	6.78	1.52	6.24

$P_N$	= Rated power	$M_N$	= Rated torque of rotor
$n_p$	= Number of poles	$M_0$	= Standstill torque
$U_N$	= Rated voltage	$M_{MAX}$	= Maximum torque
$I_N$	= Rated current	$R_M$	= Phase to phase resistance
$I_0$	= Standstill current	$L_{SD}$	= d-axis inductance
$I_{MAX}$	= Maximum current	$L_{SQ}$	= q-axis inductance
$f_N$	= Rated frequency	$k_e$	= EMF (mutual induction voltage constant)
$\eta$	= Efficiency	$T_e$	= Electrical time constant
$n_N$	= Rated torque of rotor	$k_{TN}$	= Torque constant
$J_R$	= Rotor moment of inertia	$U_{SH}$	= Heating voltage

# DRUM MOTOR DM SERIES DM 0113

## Mechanical data for 3-phase asynchronous motor with steel gear

$P_N$ [W]	$n_p$	gs	i	v [m/s]	$n_A$ [min <sup>-1</sup> ]	$M_A$ [Nm]	$F_N$ [N]	$FW_{MIN}$ [mm]	$SL_{MIN}$ [mm]
160	4	3	168	0.05	8.3	157.0	2767	277	270
160	4	3	150	0.06	9.3	140.2	2470	277	270
160	4	3	120	0.07	11.6	112.1	1976	277	270
160	4	2	73.8	0.11	18.9	72.6	1279	257	250
160	4	2	63	0.13	22.2	62.0	1092	257	250
160	4	2	45	0.18	31.0	44.3	780	257	250
160	4	2	36	0.23	38.8	35.4	624	257	250
160	4	2	30	0.28	46.6	29.5	520	257	250
160	4	2	27	0.31	51.7	26.6	468	257	250
160	4	2	24	0.35	58.2	23.6	416	257	250
160	4	2	20	0.41	69.9	19.7	347	257	250
160	4	2	16	0.52	87.3	15.7	277	257	250
160	4	2	12	0.69	116.4	11.8	208	257	250
160	4	1	9	0.92	155.2	9.3	164	257	250
225	2	2	73.8	0.22	37.4	52.0	915	257	250
225	2	2	63	0.26	43.8	44.3	781	257	250
225	2	2	45	0.36	61.3	31.7	558	257	250
225	2	2	36	0.46	76.6	25.3	447	257	250
225	2	2	30	0.55	91.9	21.1	372	257	250
225	2	2	27	0.61	102.1	19.0	335	257	250
225	2	2	24	0.68	114.9	16.9	298	257	250
225	2	2	20	0.82	137.9	14.1	248	257	250
225	2	2	16	1.02	172.4	11.3	198	257	250
225	2	2	12	1.37	229.8	8.4	149	257	250
225	2	1	9	1.82	306.4	6.7	118	257	250
300	4	2	63	0.13	21.8	118.8	2094	307	300
300	4	2	45	0.18	30.5	84.9	1496	307	300
300	4	2	36	0.23	38.1	67.9	1197	307	300
300	4	2	30	0.27	45.7	56.6	997	307	300
300	4	2	27	0.30	50.8	50.9	897	307	300
300	4	2	24	0.34	57.1	45.3	798	307	300
300	4	2	20	0.41	68.6	37.7	665	307	300
300	4	2	16	0.51	85.7	30.2	532	307	300

DL series

DM series

DP series

Application notes

# DRUM MOTOR

## DM SERIES

### DM 0113



$P_N$ [W]	$n_p$	gs	i	v [m/s]	$n_A$ [min <sup>-1</sup> ]	$M_A$ [Nm]	$F_N$ [N]	$FW_{MIN}$ [mm]	$SL_{MIN}$ [mm]
370	2	2	73.8	0.22	37.7	84.6	1491	307	300
370	2	2	63	0.26	44.1	72.2	1272	307	300
370	2	2	49.2	0.34	56.5	56.4	994	307	300
370	2	2	45	0.37	61.8	51.6	909	307	300
370	2	2	42	0.39	66.2	48.1	848	307	300
370	2	2	36	0.46	77.2	41.3	727	307	300
370	2	2	32.8	0.50	84.7	37.6	662	307	300
370	2	2	30	0.55	92.6	34.4	606	307	300
370	2	2	27	0.61	102.9	30.9	545	307	300
370	2	2	24	0.69	115.8	27.5	485	297	290
370	2	2	20	0.83	139.0	22.9	404	307	300
370	2	2	18	0.92	154.4	20.6	364	307	300
370	2	2	16	1.03	173.7	18.3	323	307	300
370	2	1	9	1.83	308.8	10.9	191	307	300
550	2	2	42	0.40	67.0	70.9	1249	317	310
550	2	2	36	0.46	78.1	60.8	1071	317	310
550	2	2	32.8	0.51	85.8	55.4	975	317	310
550	2	2	30	0.56	93.8	50.6	892	317	310
550	2	2	27	0.62	104.2	45.6	803	317	310
550	2	2	24	0.70	117.2	40.5	714	317	310
550	2	2	20	0.84	140.7	33.8	595	317	310
550	2	2	16	1.04	175.8	27.0	476	317	310
550	2	2	12	1.39	234.4	20.3	357	317	310
550	2	1	9	1.86	312.6	16.0	282	317	310

$P_N$  = Rated power  
 $n_p$  = Number of poles  
 gs = Gear stages  
 i = Speed ratio  
 v = Speed

$n_A$  = Shell rated speed  
 $M_A$  = Drum motor rated torque  
 $F_N$  = Drum motor rated belt pull  
 $FW_{MIN}$  = Minimum drum width  
 $SL_{MIN}$  = Minimum shell length

# DRUM MOTOR DM SERIES DM 0113

## Electrical data for 3-phase asynchronous motor

$P_N$ [W]	$n_p$	$n_N$ [min <sup>-1</sup> ]	$f_N$ [Hz]	$U_N$ [V]	$I_N$ [A]	$I_0$ [A]	$\cos\varphi$	$\eta$ [%]	$J_R$ [kgm <sup>2</sup> ]	$I_s/I_N$	$M_s/M_N$	$M_B/M_N$	$M_P/M_N$	$M_N$ [Nm]	$R_M$ [Ω]	$U_{SH\Delta}$ [V]	$U_{SHY}$ [V]
160	4	1397	50	400	0.54	0.47	0.70	60.5	3.8	3.05	1.92	2.13	1.92	1.09	63.7		36.4
160	4	1397	50	230	0.94	0.82	0.70	60.5	3.8	3.05	1.92	2.13	1.92	1.09	64.0	21.0	
225	2	2758	50	400	0.56	0.33	0.86	67.8	2.5	4.32	2.57	2.62	2.57	0.78	39.3		28.1
225	2	2758	50	230	0.96	0.56	0.86	67.8	2.5	4.32	2.57	2.62	2.57	0.78	39.3	16.2	
300	4	1371	50	400	0.81	0.56	0.76	69.7	6.8	3.28	1.80	1.95	1.80	2.09	33.5		31.0
300	4	1371	50	230	1.40	0.96	0.76	69.7	6.8	3.28	1.80	1.95	1.80	2.09	33.5	17.9	
370	2	2779	50	400	0.82	0.4	0.87	74.2	4.40	5.47	2.91	2.91	2.88	1.27	19.85		21.29
370	2	2779	50	230	1.42	0.7	0.87	74.2	4.40	5.47	2.91	2.91	2.88	1.27	19.85	12.3	
550	2	2813	50	400	1.23	0.7	0.85	76.5	5.44	5.77	3.27	3.27	3.15	1.87	11.60		18.13
550	2	2813	50	230	2.13	1.2	0.85	76.5	5.44	5.77	3.27	3.27	3.15	1.87	11.60	10.5	

$P_N$	= Rated power	$I_s/I_N$	= Ratio of startup current – rated current
$n_p$	= Number of poles	$M_s/M_N$	= Ratio of startup torque – rated torque
$n_N$	= Rated speed of rotor	$M_B/M_N$	= Ratio of pull-out torque – rated torque
$f_N$	= Rated frequency	$M_P/M_N$	= Ratio of pull-up torque – rated torque
$U_N$	= Rated voltage	$M_N$	= Rated torque of rotor
$I_N$	= Rated current	$R_M$	= Branch resistance
$\cos\varphi$	= Power factor	$U_{SH\Delta}$	= Heater voltage in delta connection
$\eta$	= Efficiency	$U_{SHY}$	= Heater voltage in star connection
$J_R$	= Rotor moment of inertia		

# DRUM MOTOR

## DM SERIES

### DM 0113

#### Mechanical data for 1-phase asynchronous motor with steel gear

$P_N$ [W]	$n_p$	gs	i	v [m/s]	$n_A$ [1/min]	$M_A$ [Nm]	$F_N$ [N]	$FW_{MIN}$ [mm]	$SL_{MIN}$ [mm]
250	4	2	45	0.18	30.2	71.5	1265	307	300
250	4	2	36	0.22	37.8	57.2	1012	307	300
250	4	2	30	0.27	45.3	47.7	843	307	300
250	4	2	27	0.3	50.4	42.9	759	307	300
250	4	2	24	0.34	56.7	38.1	675	307	300
250	4	2	20	0.4	68	31.8	562	307	300
250	4	2	16	0.5	85	25.4	450	307	300
250	4	2	12	0.67	113.3	19.1	337	307	300

$P_N$	= Rated power	$M_A$	= Drum motor rated torque
$n_p$	= Number of poles	$F_N$	= Drum motor rated belt pull
gs	= Gear stages	$M_{MAX}/M_A$	= Ratio of max. acceleration torque to rated torque
i	= Speed ratio	$FW_{MIN}$	= Minimum drum width
v	= Speed	$SL_{MIN}$	= Minimum shell length
$n_A$	= Shell rated speed		

#### Electrical data for 1-phase asynchronous motor

$P_N$ [W]	$n_p$	$n_N$ [min <sup>-1</sup> ]	$f_N$ [Hz]	$U_N$ [V]	$I_N$ [A]	cosφ	η [%]	$J_R$ [kgcm <sup>2</sup> ]	$I_S/I_N$	$M_S/M_N$	$M_B/M_N$	$M_P/M_N$	$M_N$ [Nm]	$R_M$ [Ω]	$U_{SH-}$ [V DC]	$C_R$ [μF]
250	4	1360	50	230	2.4	0.97	0.5	7.2	1.25	1.1	1.1	1.1	1.76	12.7	44.3	12

$P_N$	= Rated power	$I_S/I_N$	= Ratio of startup current – rated current
$n_p$	= Number of poles	$M_S/M_N$	= Ratio of startup torque – rated torque
$n_N$	= Rated speed of rotor	$M_B/M_N$	= Ratio of pull-out torque – rated torque
$f_N$	= Rated frequency	$M_P/M_N$	= Ratio of pull-up torque – rated torque
$U_N$	= Rated voltage	$M_N$	= Rated torque of rotor
$I_N$	= Rated current	$R_M$	= Branch resistance
cosφ	= Power factor	$U_{SH-}$	= Heater voltage for DC units
η	= Efficiency	$C_R$	= Capacitor size
$J_R$	= Rotor moment of inertia		



## Belt tension diagrams

### Belt tension depending on drum width

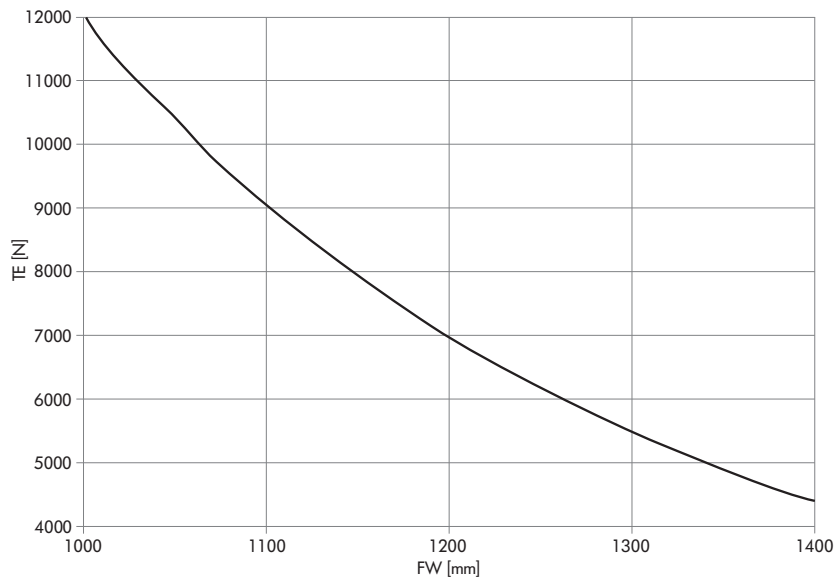

### Belt tension depending on rated speed of shell

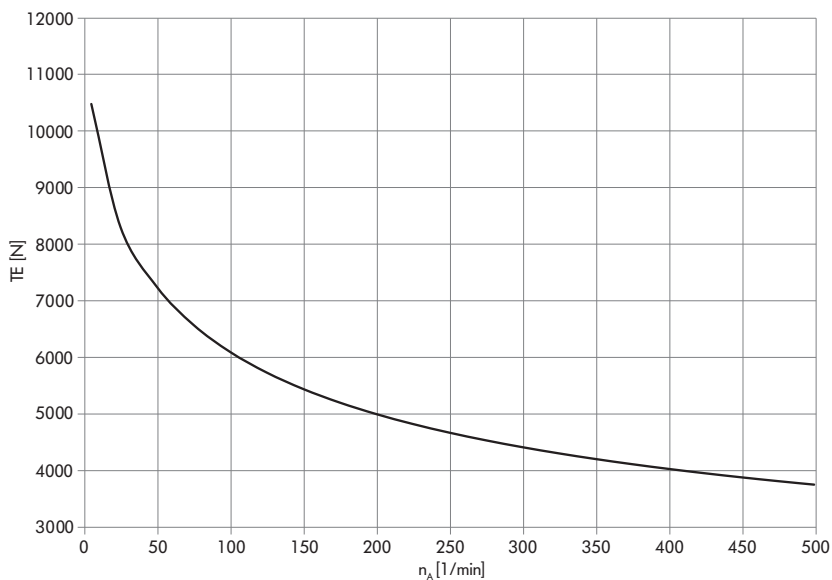

**Note:** The correct value for the maximum permissible belt tension is determined from the speed of the drum motor. When selecting the motor, also check whether the maximum permissible TE value fits the desired drum width (FW). The belt tension diagrams apply only to standard shafts.

- TE = Belt tension
- $n_A$  = Shell rated speed
- FW = Drum width

# DRUM MOTOR

## DM SERIES

### DM 0113

#### Dimensions

#### Drum motor

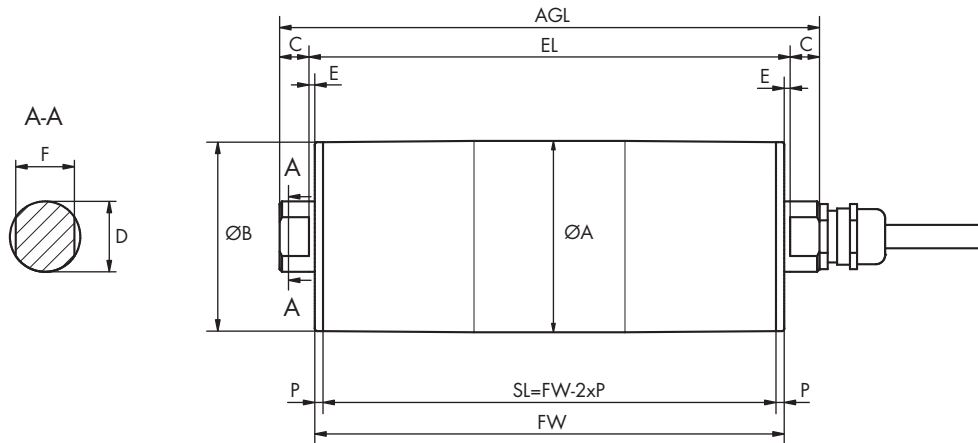

Type		A [mm]	B [mm]	C [mm]	D [mm]	S [mm]	F [mm]	P [mm]	SL [mm]	EL [mm]	AGL [mm]
<b>DM 0113 crowned</b>	Standard	113.5	112	25	30	6.5	25	3.5	FW - 7	FW + 13	FW + 63
	Optional	113.5	112	25	25	6.5	20	3.5	FW - 7	FW + 13	FW + 63
<b>DM 0113 cylindrical</b>	Standard	112	112	25	30	6.5	25	3.5	FW - 7	FW + 13	FW + 63
	Optional	112	112	25	25	6.5	20	3.5	FW - 7	FW + 13	FW + 63
<b>DM 0113 cylindrical + key</b>	Standard	113	113	25	30	6.5	25	3.5	FW - 7	FW + 13	FW + 63
	Optional	113	113	25	25	6.5	20	3.5	FW - 7	FW + 13	FW + 63

**DRUM MOTOR  
DM SERIES  
DM 0113**



DL series

**DM series**

DP series

Application notes

# DRUM MOTOR

## DM SERIES

### DM 0138



Practice-oriented, scalable and thought out in detail: The new drum motor DM 0138 makes it easy to build a completely individual conveyor system and is dimensioned for the higher requirements of permissible belt tension now demanded from industry and belt manufacturers alike.

With a broader speed spectrum, the DM 0138 covers all possible applications. The clever plug-and-play connection significantly simplifies the installation. Each motor is approved, tested, and modularized so that it can be produced and delivered around the world in the shortest amount of time.

The modular design of the DM 0138 allows a free combination of individual module groups, such as shaft, end housing, shell or steel gear, to perfectly meet the requirements of an application. In addition, various options, such as encoder, brake, backstop, rubber laggings, etc., as well as different accessories are available.

With the platform concept of the DM 0138, it is possible to cover all internal logistics applications in the food processing sector, as well as in industry, distribution and airports.



## Technical data

	Asynchronous squirrel cage motor	AC synchronous permanent magnet motor
<b>Insulation class of motor windings</b>	Class F, IEC 34 (VDE 0530)	Class F, IEC 34 (VDE 0530)
<b>Voltage</b>	230/400 V $\pm 5\%$ (IEC 34/38) Most of the common international voltages and frequencies are available upon request	230 or 400 V
<b>Frequency</b>	50 Hz	200 Hz
<b>Shaft seal, internal</b>	NBR	NBR
<b>Protection rate Motor*</b>	IP69K	IP69K
<b>Thermal controller</b>	Bi-metal switch	Bi-metal switch
<b>Operating mode</b>	S1	S1
<b>Ambient temperature, 3-phase motor</b>	+2 to +40 °C Low temperature ranges on request	+2 to +40 °C Low temperature ranges on request
<b>Ambient temperature, 3-phase motor for applications with form-fit belts or no belt</b>	+2 to +25 °C	+2 to +40 °C

\* The protection rate of the cable connector may deviate.

## Design variants and accessories

<b>Lagging</b>	Lagging for friction drive belts Lagging for modular plastic belts Lagging for positive drive solid homogeneous belts
<b>Sprockets</b>	Sprockets
<b>Options</b>	Backstop Electromagnetic holding brake and rectifier* Encoder* Balancing Plug connection*
<b>Oils</b>	Food-grade oils (EU, FDA, NSF H1)
<b>Certificate</b>	cULus safety certificates
<b>Accessories</b>	Idler pulleys; conveyor rollers; mounting brackets; cables; inverters

A combination of encoder and safety holding brake is not possible. In addition, the use of a backstop with a synchronous motor is technically not meaningful.

\* Depending on the option, the motor extends by 50 – 70 mm.

# DRUM MOTOR

## DM SERIES

### DM 0138

#### Material variants

The following components can be selected for the drum motor and the electrical connection. The combination of components depends on the material used.

Component	Version	Aluminum	Mild steel	Stainless steel	Brass/nickel	Technopolymer
<b>Shell</b>	Crowned		●	●		
	Cylindrical		●	●		
	Cylindrical + key for sprockets		●	●		
<b>End housing</b>	Standard	●		●		
<b>Shaft</b>	Standard			●		
	Cross-drilled thread			●		
<b>Gear boxes</b>	Planetary gear box		●			
<b>Electrical connector</b>	Straight connector			●	●	●
	Straight hygienic connector			●		
	Elbow connector			●		●
	Terminal box	●		●		●
	Straight plug connection			●		
	90° plug connection			●		
	90° hygienic connector			●		
<b>Motor winding</b>	Asynchronous motor					
	Synchronous motor					
<b>External seal</b>	PTFE					

## Motor variants

### Mechanical data for synchronous motors with steel gear

$P_N$ [W]	$n_p$	gs	i	v [m/s]	$n_A$ [min <sup>-1</sup> ]	$M_A$ [Nm]	$F_N$ [N]	$M_{MAX}/M_A$	$FW_{MIN}$ [mm]	$SL_{MIN}$ [mm]
1800	8	2	30	0.72	100.0	155.1	2,248	1.35	357	350
1800	8	2	27	0.80	111.1	139.6	2,024	1.55	357	350
1800	8	2	24	0.90	125.0	124.1	1,799	1.65	357	350
1800	8	2	20	1.08	150.0	103.4	1,499	2.3	357	350
1800	8	2	16	1.35	187.5	82.7	1,199	2.8	357	350
1800	8	2	12	1.81	250.0	62.1	899	3	357	350
1800	8	1	9	2.41	333.3	49.0	710	3	357	350

$P_N$	= Rated power	$M_A$	= Drum motor rated torque
$n_p$	= Number of poles	$F_N$	= Drum motor rated belt pull
gs	= Gear stages	$M_{MAX}/M_A$	= Ratio of max. acceleration torque to rated torque
i	= Speed ratio	$FW_{MIN}$	= Minimum drum width
v	= Speed	$SL_{MIN}$	= Minimum shell length
$n_A$	= Shell rated speed		

### Electrical data for synchronous motors

$P_N$ [W]	$n_p$	$U_N$ [V]	$I_N$ [A]	$I_0$ [A]	$I_{MAX}$ [A]	$f_N$ [Hz]	$\eta$	$n_N$ [1/min]	$J_R$ [kgcm <sup>2</sup> ]	$M_N$ [Nm]	$M_0$ [Nm]	$M_{MAX}$ [Nm]	$R_M$ [Ω]	$L_{SD}$ [mH]	$L_{SQ}$ [mH]	$k_e$ [V/krpm]	$T_e$ [ms]	$k_{TN}$ [Nm/A]	$U_{SH}$ [V]
1800	8	230	5.94	5.94	17.82	200	0.92	3000	14.4	5.73	3.18	17.19	2.17	3.87	5.63	63.60	7.72	0.96	4.34
1800	8	400	3.43	3.43	10.29	200	0.92	3000	14.4	5.73	3.18	17.19	2.17	11.60	16.90	110.20	7.79	1.67	22.33

$P_N$	= Rated power	$M_N$	= Rated torque of rotor
$n_p$	= Number of poles	$M_0$	= Standstill torque
$U_N$	= Rated voltage	$M_{MAX}$	= Maximum torque
$I_N$	= Rated current	$R_M$	= Phase to phase resistance
$I_0$	= Standstill current	$L_{SD}$	= d-axis inductance
$I_{MAX}$	= Maximum current	$L_{SQ}$	= q-axis inductance
$f_N$	= Rated frequency	$k_e$	= EMF (mutual induction voltage constant)
$\eta$	= Efficiency	$T_e$	= Electrical time constant
$n_N$	= Rated torque of rotor	$k_{TN}$	= Torque constant
$J_R$	= Rotor moment of inertia	$U_{SH}$	= Heating voltage

# DRUM MOTOR

## DM SERIES

### DM 0138

#### Mechanical data for synchronous motors with oil-free steel gear

$P_N$ [W]	$n_p$	gs	i	v [m/s]	$n_A$ [min <sup>-1</sup> ]	$M_A$ [Nm]	$F_N$ [N]	$M_{MAX}/M_A$	$FW_{MIN}$ [mm]	$SL_{MIN}$ [mm]
1000	8	2	49.2	0.44	61.0	141.2	2,046	1.6	357	350
1000	8	2	45	0.48	66.7	129.1	1,872	1.8	357	350
1000	8	2	42	0.52	71.4	120.5	1,747	1.9	357	350
1000	8	2	36	0.60	83.3	103.3	1,497	2.2	357	350
1000	8	2	30	0.72	100.0	86.1	1,248	2.7	357	350
1000	8	2	27	0.80	111.1	77.5	1,123	3	357	350
1000	8	2	24	0.90	125.0	68.9	998	3	357	350
1000	8	2	20	1.08	150.0	57.4	832	3	357	350
1000	8	2	16	1.35	187.5	45.9	665	3	357	350
1000	8	2	12	1.81	250.0	34.4	499	3	357	350
1000	8	1	9	2.41	333.3	27.2	394	3	357	350

$P_N$	= Rated power	$M_A$	= Drum motor rated torque
$n_p$	= Number of poles	$F_N$	= Drum motor rated belt pull
gs	= Gear stages	$M_{MAX}/M_A$	= Ratio of max. acceleration torque to rated torque
i	= Speed ratio	$FW_{MIN}$	= Minimum drum width
v	= Speed	$SL_{MIN}$	= Minimum shell length
$n_A$	= Shell rated speed		

#### Electrical data for oil-free synchronous motors

$P_N$ [W]	$n_p$	$U_N$ [V]	$I_N$ [A]	$I_0$ [A]	$I_{MAX}$ [A]	$f_N$ [Hz]	$\eta$	$n_N$ [1/min]	$J_R$ [kgcm <sup>2</sup> ]	$M_N$ [Nm]	$M_0$ [Nm]	$M_{MAX}$ [Nm]	$R_M$ [ $\Omega$ ]	$L_{SD}$ [mH]	$L_{SQ}$ [mH]	$k_e$ [V/krpm]	$T_e$ [ms]	$k_{TN}$ [Nm/A]	$U_{SH}$ [V]
1000	8	230	3.36	3.36	10.08	200	0.93	3000	14.4	3.18	3.18	9.54	1.46	3.87	5.63	63.60	7.72	0.95	2.45
1000	8	400	1.94	1.94	5.82	200	0.93	3000	14.4	3.18	3.18	9.54	4.34	11.60	16.90	110.20	7.73	1.64	12.72

$P_N$	= Rated power	$M_N$	= Rated torque of rotor
$n_p$	= Number of poles	$M_0$	= Standstill torque
$U_N$	= Rated voltage	$M_{MAX}$	= Maximum torque
$I_N$	= Rated current	$R_M$	= Phase to phase resistance
$I_0$	= Standstill current	$L_{SD}$	= d-axis inductance
$I_{MAX}$	= Maximum current	$L_{SQ}$	= q-axis inductance
$f_N$	= Rated frequency	$k_e$	= EMF (mutual induction voltage constant)
$\eta$	= Efficiency	$T_e$	= Electrical time constant
$n_N$	= Rated torque of rotor	$k_{TN}$	= Torque constant
$J_R$	= Rotor moment of inertia	$U_{SH}$	= Heating voltage



# DRUM MOTOR DM SERIES DM 0138

## Mechanical data for 3-phase asynchronous motor with steel gear

$P_N$ [W]	$n_p$	gs	i	v [m/s]	$n_A$ [min <sup>-1</sup> ]	$M_A$ [Nm]	$F_N$ [N]	$FW_{MIN}$ [mm]	$SL_{MIN}$ [mm]
160	4	3	252	0.04	5.5	238	3454	307	300
160	4	3	150	0.07	9.2	142	2056	307	300
160	4	3	120	0.08	11.5	113	1645	307	300
160	4	3	100	0.1	13.9	95	1371	307	300
370	4	2	73.8	0.14	18.8	169	2452	307	300
370	4	2	63	0.16	22.0	144	2093	307	300
370	4	2	49.2	0.2	28.2	113	1635	307	300
370	4	2	42	0.24	33.1	96	1395	307	300
370	4	2	36	0.28	38.6	83	1196	307	300
370	4	2	30	0.33	46.3	69	997	307	300
370	4	2	27	0.37	51.4	62	897	307	300
370	4	2	24	0.42	57.9	55	797	307	300
370	4	2	20	0.5	69.5	46	664	307	300
370	4	2	16	0.63	86.8	37	532	307	300
370	4	2	12	0.84	115.8	28	399	307	300
370	4	1	9	1.11	154.3	22	315	307	300
550	2	2	73.8	0.28	38.7	123	1776	307	300
550	2	2	63	0.33	45.3	105	1516	307	300
550	2	2	49.2	0.42	58.0	82	1184	307	300
550	2	2	42	0.49	68.0	70	1011	307	300
550	2	2	36	0.57	79.3	60	866	307	300
550	2	2	30	0.69	95.2	50	722	307	300
550	2	2	27	0.76	105.7	45	650	307	300
550	2	2	24	0.86	119.0	40	578	307	300
550	2	2	20	1.03	142.8	33	481	307	300
550	2	2	16	1.29	178.4	27	385	307	300
550	2	2	12	1.72	237.9	20	289	307	300
550	2	1	9	2.29	317.2	16	228	307	300

DL series

DM series

DP series

Application notes

# DRUM MOTOR

## DM SERIES

### DM 0138



$P_N$ [W]	$n_p$	gs	i	v [m/s]	$n_A$ [min <sup>-1</sup> ]	$M_A$ [Nm]	$F_N$ [N]	$FW_{MIN}$ [mm]	$SL_{MIN}$ [mm]
750	4	2	42	0.24	33.3	194	2807	357	350
750	4	2	36	0.28	38.9	166	2406	357	350
750	4	2	30	0.34	46.7	138	2005	357	350
750	4	2	27	0.37	51.9	125	1805	357	350
750	4	2	20	0.51	70.0	92	1337	357	350
750	4	2	16	0.63	87.5	74	1069	357	350
750	4	2	12	0.84	116.7	55	802	357	350
750	4	1	9	1.12	155.6	44	633	357	350
1000	2	2	49.2	0.42	57.9	150	2169	357	350
1000	2	2	42	0.49	67.9	128	1851	357	350
1000	2	2	36	0.57	79.2	109	1587	357	350
1000	2	2	30	0.69	95.0	91	1322	357	350
1000	2	2	27	0.76	105.6	82	1190	357	350
1000	2	2	24	0.86	118.8	73	1058	357	350
1000	2	2	20	1.03	142.6	61	882	357	350
1000	2	2	16	1.29	178.2	49	705	357	350
1000	2	2	12	1.72	237.6	36	529	357	350
1000	2	1	9	2.29	316.8	29	418	357	350

$P_N$  = Rated power  
 $n_p$  = Number of poles  
 gs = Gear stages  
 i = Speed ratio  
 v = Speed

$n_A$  = Shell rated speed  
 $M_A$  = Drum motor rated torque  
 $F_N$  = Drum motor rated belt pull  
 $FW_{MIN}$  = Minimum drum width  
 $SL_{MIN}$  = Minimum shell length

# DRUM MOTOR DM SERIES DM 0138

## Electrical data for 3-phase asynchronous motor

$P_N$ [W]	$n_p$	$n_N$ [min <sup>-1</sup> ]	$f_N$ [Hz]	$U_N$ [V]	$I_N$ [A]	$\cos\varphi$	$\eta$ [%]	$J_R$ [kgcm <sup>2</sup> ]	$I_s/I_N$	$M_s/M_N$	$M_B/M_N$	$M_P/M_N$	$M_N$ [Nm]	$R_M$ [Ω]	$U_{SH\Delta}$ [V]	$U_{SHY}$ [V]
160	4	1390	50	400	0.46	0.76	0.67	3.98	3.5	1.86	2.13	1.86	1.1	60.2		30.7
160	4	1390	50	230	0.79	0.76	0.67	3.98	3.5	1.86	2.13	1.86	1.1	60.2	18.2	
370	4	1389	50	400	1.01	0.75	0.71	6.48	4.07	2.24	2.28	2.00	2.5	21.1		23.7
370	4	1389	50	230	1.74	0.75	0.71	6.48	4.07	2.24	2.28	2.00	2.5	21.1	13.7	
550	2	2855	50	400	1.28	0.77	0.80	4.21	5.49	2.82	3.26	2.82	1.8	11.8		17.4
550	2	2855	50	230	2.21	0.77	0.80	4.21	5.49	2.82	3.26	2.82	1.8	11.8	10.1	
750	4	1400	50	400	1.86	0.77	0.77	11.45	4.47	2.29	2.41	2.07	5.1	9.1		19.4
750	4	1400	50	230	3.22	0.77	0.77	11.45	4.47	2.29	2.41	2.07	5.1	9.1	11.2	
1000	2	2851	50	400	2.03	0.84	0.84	7.45	6.25	2.91	3.12	2.91	3.4	5.7		14.7
1000	2	2851	50	230	3.52	0.84	0.84	7.45	6.25	2.91	3.12	2.91	3.4	5.7	8.5	

$P_N$	= Rated power	$I_s/I_N$	= Ratio of startup current – rated current
$n_p$	= Number of poles	$M_s/M_N$	= Ratio of startup torque – rated torque
$n_N$	= Rated speed of rotor	$M_B/M_N$	= Ratio of pull-out torque – rated torque
$f_N$	= Rated frequency	$M_P/M_N$	= Ratio of pull-up torque – rated torque
$U_N$	= Rated voltage	$M_N$	= Rated torque of rotor
$I_N$	= Rated current	$R_M$	= Branch resistance
$\cos\varphi$	= Power factor	$U_{SH\Delta}$	= Heater voltage in delta connection
$\eta$	= Efficiency	$U_{SHY}$	= Heater voltage in star connection
$J_R$	= Rotor moment of inertia		

# DRUM MOTOR DM SERIES DM 0138

## Belt tension diagrams

### Belt tension depending on drum width

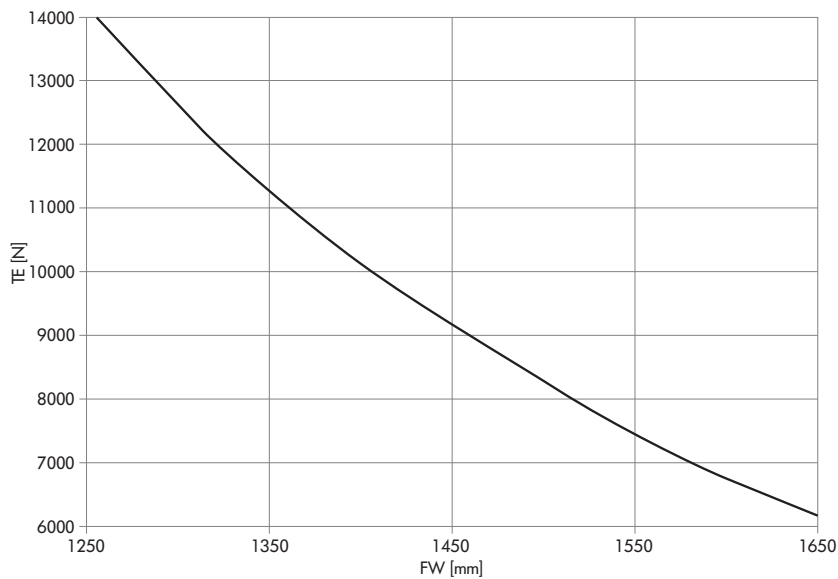

### Belt tension depending on rated speed of shell

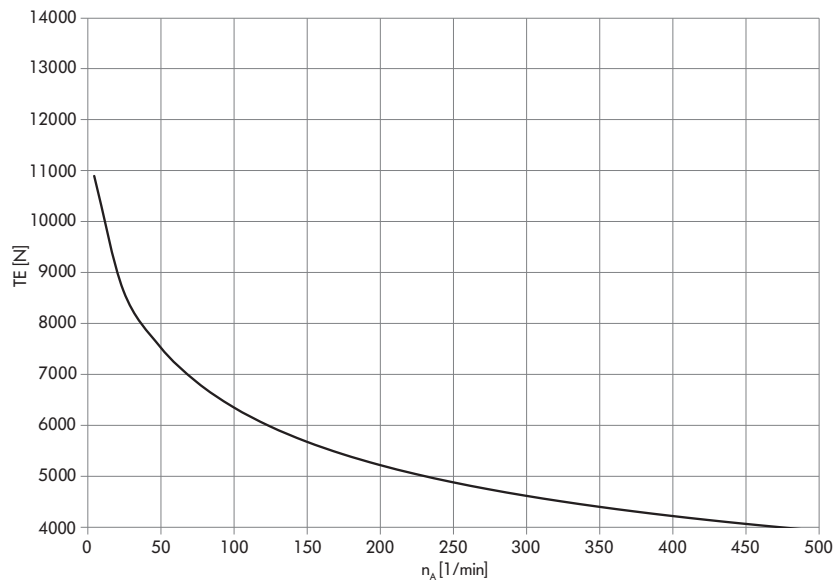

**Note:** The correct value for the maximum permissible belt tension is determined from the speed of the drum motor. When selecting the motor, also check whether the maximum permissible TE value fits the desired drum width (FW). The belt tension diagrams apply only to standard shafts.

- TE = Belt tension
- n<sub>A</sub> = Shell rated speed
- FW = Drum width

# DRUM MOTOR DM SERIES DM 0138

## Dimensions

### Drum motor

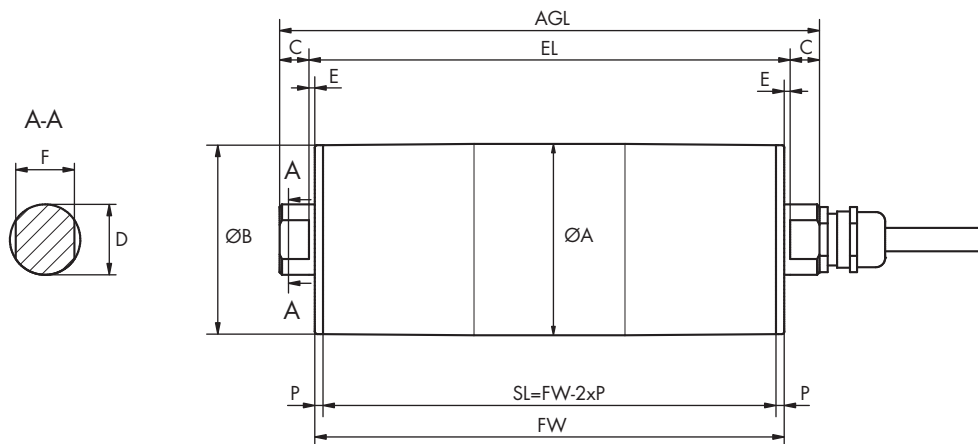

Type		A [mm]	B [mm]	C [mm]	D [mm]	S [mm]	F [mm]	P [mm]	SL [mm]	EL [mm]	AGL [mm]
<b>DM 0138 crowned</b>	Standard	138	136	25	30	11.5	25	3.5	FW - 7	FW + 23	FW + 73
	Optional	138	136	25	30	11.5	20	3.5	FW - 7	FW + 23	FW + 73
<b>DM 0138 cylindrical</b>	Standard	136	136	25	30	11.5	25	3.5	FW - 7	FW + 23	FW + 73
	Optional	136	136	25	30	11.5	20	3.5	FW - 7	FW + 23	FW + 73
<b>DM 0138 cylindrical + key</b>	Standard	137	137	25	30	11.5	25	3.5	FW - 7	FW + 23	FW + 73
	Optional	137	137	25	30	11.5	20	3.5	FW - 7	FW + 23	FW + 73

# DRUM MOTOR

## DM SERIES

### DM 0165



Practice-oriented, scalable and thought out in detail: The new drum motor DM 0165 makes it easy to build a completely individual conveyor system and is dimensioned for the higher requirements of permissible belt tension now demanded from industry and belt manufacturers alike.

With a broader speed spectrum, the DM 0165 covers all possible applications. The clever plug-and-play connection significantly simplifies the installation. Each motor is approved, tested, and modularized so that it can be produced and delivered around the world in the shortest amount of time.

The modular design of the DM 0165 allows a free combination of individual module groups, such as shaft, end housing, shell or steel gear, to perfectly meet the requirements of an application. In addition, various options, such as encoder, brake, backstop, rubber laggings, etc., as well as different accessories are available.

With the platform concept of the DM 0165, it is possible to cover all internal logistics applications in the food processing sector, as well as in industry, distribution and airports.



## Technical data

	Asynchronous squirrel cage motor
Insulation class of motor windings	Class F, IEC 34 (VDE 0530)
Voltage	230/400 V 3-phase $\pm 5\%$ (IEC 34/38) Most of the common international voltages and frequencies are available upon request
Frequency	50 Hz
Shaft seal, internal	NBR
Protection rate Motor*	IP69K
Thermal controller	Bi-metal switch
Operating mode	S1
Ambient temperature, 3-phase motor	+2 to +40 °C
Ambient temperature, 3-phase motor for applications with form-fit belts or no belt	+2 to +25 °C

\* The protection rate of the cable connector may deviate.

## Design variants and accessories

Lagging	Lagging for friction drive belts Lagging for modular plastic belts Lagging for positive drive solid homogeneous belts
Sprockets	Sprockets only on request
Options	Backstop Electromagnetic holding brake and rectifier* Encoder* Balancing Plug connection (only up to 1100 W)
Oils	Food-grade oils (EU, FDA, NSF H1)
Certificate	cULus safety certificates
Accessories	Idler pulleys; conveyor rollers; mounting brackets; cables; inverters

\* Depending on the option, the motor extends by 50 mm.

# DRUM MOTOR

## DM SERIES

### DM 0165

#### Material variants

The following components can be selected for the drum motor and the electrical connection. The combination of components depends on the material used.

Component	Version	Aluminum	Mild steel	Stainless steel	Brass/nickel	Technopolymer
<b>Shell</b>	Crowned		●	●		
	Cylindrical		●	●		
	Cylindrical + key for sprockets		●	●		
<b>End housing</b>	Standard	●		●		
<b>Shaft</b>	Standard			●		
	Cross-drilled thread			●		
<b>Gear boxes</b>	Spur gear box		●			
<b>Electrical connector</b>	Straight connector			●	●	●
	Straight hygienic connector			●		
	Elbow connector			●		●
	Terminal box	●		●		●
	Straight plug connection			●		
	90° plug connection			●		
	90° hygienic connector			●		
<b>Motor winding</b>	Asynchronous motor					
<b>External seal</b>	PTFE					



# DRUM MOTOR DM SERIES DM 0165

## Motor variants

### Mechanical data for 3-phase asynchronous motor

$P_N$ [W]	np	gs	i	v [m/s]	$n_A$ [min <sup>-1</sup> ]	$M_A$ [Nm]	$F_N$ [N]	$FW_{MIN}$ [mm]	$SL_{MIN}$ [mm]
370	12	3	46.56	0.084	9.8	339.6	4142	457	450
370	8	3	62.37	0.100	11.1	300.6	3666	407	400
370	8	3	46.56	0.127	14.8	224.4	2736	407	400
370	4	3	62.37	0.189	22.0	158.5	1933	407	400
370	4	3	46.56	0.254	29.5	118.3	1443	407	400
370	4	3	39.31	0.300	35.0	99.9	1218	407	400
370	4	3	31.56	0.374	43.6	80.2	978	407	400
370	4	3	24.60	0.480	55.9	62.5	762	407	400
370	4	2	19.64	0.601	70.0	50.9	621	407	400
370	4	2	14.66	0.806	93.8	38.0	464	407	400
370	4	2	12.38	0.954	111.1	32.1	391	407	400
550	6	3	62.37	0.116	13.5	365.2	4453	407	400
550	6	3	46.56	0.156	18.1	272.6	3324	407	400
750	6	3	46.56	0.156	18.1	371.6	4532	457	450
750	4	3	62.37	0.187	21.7	310.6	3787	407	400
750	4	3	46.56	0.250	29.1	231.8	2827	407	400
750	4	3	39.31	0.296	34.5	195.7	2387	407	400
750	4	3	31.56	0.369	42.9	157.1	1916	407	400
750	4	3	24.60	0.473	55.1	122.5	1494	407	400
750	4	2	19.64	0.593	69.0	99.8	1217	407	400
750	4	2	14.66	0.794	92.40	74.5	908	407	400
750	4	2	12.38	0.940	109.5	62.9	767	407	400

# DRUM MOTOR

## DM SERIES

### DM 0165



$P_N$ [W]	$n_p$	$gs$	$i$	$v$ [m/s]	$n_A$ [min <sup>-1</sup> ]	$M_A$ [Nm]	$F_N$ [N]	$FW_{MIN}$ [mm]	$SL_{MIN}$ [mm]
1100	4	3	46.56	0.243	28.4	348.8	4254	407	400
1100	4	3	39.31	0.288	33.6	294.5	3591	407	400
1100	4	3	31.56	0.359	41.8	236.4	2883	407	400
1100	4	3	24.60	0.461	53.7	184.3	2248	407	400
1100	4	2	19.64	0.577	67.2	150.1	1831	407	400
1100	4	2	14.66	0.773	90.1	112.1	1366	407	400
1100	4	2	12.38	0.916	106.7	94.6	1154	407	400
1100	2	3	46.56	0.525	61.1	161.7	1972	407	400
1100	2	3	39.31	0.621	72.4	136.5	1665	407	400
1100	2	3	24.60	0.993	115.7	85.4	1042	407	400
1100	2	2	19.64	1.244	144.9	69.6	849	407	400
1100	2	2	14.66	1.667	194.1	51.9	633	407	400
1100	2	2	12.38	1.974	229.9	43.9	535	407	400
1100	2	2	9.65	2.532	294.8	34.2	417	407	400
1500	4	3	31.56	0.379	44.1	305.3	3723	457	450
1500	4	3	24.60	0.486	56.6	238.0	2903	457	450
1500	4	2	19.64	0.609	70.9	193.9	2364	457	450
1500	4	2	14.66	0.816	95.0	144.7	1765	457	450
1500	4	2	12.38	0.967	112.6	122.20	1490	457	450
2200	2	3	46.56	0.524	61.0	324.3	3954	457	450
2200	2	3	39.31	0.620	72.2	273.8	3339	457	450
2200	2	3	31.56	0.773	90.0	219.8	2680	457	450
2200	2	3	24.60	0.991	115.4	171.3	2089	457	450
2200	2	2	19.64	1.242	144.6	139.6	1702	457	450
2200	2	2	14.66	1.664	193.8	104.2	1270	457	450
2200	2	2	12.38	1.971	229.5	87.9	1073	457	450
2200	2	2	9.65	2.527	294.3	68.6	836	457	450

$P_N$  = Rated power  
 $n_p$  = Number of poles  
 $gs$  = Gear stages  
 $i$  = Speed ratio  
 $v$  = Speed

$n_A$  = Shell rated speed  
 $M_A$  = Drum motor rated torque  
 $F_N$  = Drum motor rated belt pull  
 $FW_{MIN}$  = Minimum drum width  
 $SL_{MIN}$  = Minimum shell length

# DRUM MOTOR DM SERIES DM 0165

## Electrical data for 3-phase asynchronous motor

$P_N$ [W]	$n_p$	$n_N$ [min <sup>-1</sup> ]	$f_N$ [Hz]	$U_N$ [V]	$I_N$ [A]	$\cos\varphi$	$\eta$ [%]	$J_R$ [kgcm <sup>2</sup> ]	$I_S/I_N$	$M_S/M_N$	$M_B/M_N$	$M_P/M_N$	$M_N$ [Nm]	$R_M$ [Ω]	$U_{SH\Delta}$ [V]	$U_{SHY}$ [V]
370	4	1375	50	400	1.10	0.77	0.66	11.3	3.2	1.60	1.80	1.60	2.70	29.2		37
370	4	1375	50	230	1.90	0.77	0.66	11.3	3.2	1.60	1.80	1.60	2.70	29.2	21	
370	8	690	50	400	1.50	0.62	0.57	22.6	2.87	1.90	2.35	1.90	5.12	22.0		31
370	8	690	50	230	2.42	0.62	0.57	22.6	2.87	1.90	2.35	1.90	5.12	22.0	17	
370	12	456	50	400	1.60	0.63	0.53	35.1	2.0	1.20	1.50	1.20	7.75	19.4		29
370	12	456	50	230	2.77	0.63	0.53	35.1	2.0	1.20	1.50	1.20	7.75	19.4	17	
550	6	845	50	400	1.60	0.69	0.72	22.6	3.4	1.40	1.65	1.40	6.22	19.5		32
550	6	845	50	230	2.77	0.69	0.72	22.6	3.4	1.40	1.65	1.40	6.22	19.5	19	
750	4	1355	50	400	1.80	0.80	0.75	11.3	3.5	1.53	1.80	1.30	5.29	23.9		52
750	4	1355	50	230	3.12	0.80	0.75	11.3	3.5	1.53	1.80	1.30	5.29	23.9	30	
750	6	845	50	400	2.10	0.81	0.64	22.6	3.5	1.75	2.00	1.75	8.48	6.2		16
750	6	845	50	230	3.64	0.81	0.64	22.6	3.5	1.75	2.00	1.75	8.48	6.2	9	
1100	2	2845	50	400	2.40	0.86	0.77	7.6	5.2	3.15	3.42	2.10	3.69	2.9		9
1100	2	2845	50	230	4.16	0.86	0.77	7.6	5.2	3.15	3.42	2.10	3.69	2.9	5	
1100	4	1320	50	400	2.80	0.82	0.69	11.3	3.5	1.50	1.70	1.30	7.96	7.2		25
1100	4	1320	50	230	4.85	0.82	0.69	11.3	3.5	1.50	1.70	1.30	7.96	7.2	14	
1500	4	1393	50	400	3.50	0.87	0.71	19.8	3.8	1.55	2.10	1.55	10.28	5.2		24
1500	4	1393	50	230	6.06	0.87	0.71	19.8	3.8	1.55	2.10	1.55	10.28	5.2	14	
2200	2	2840	50	400	4.55	0.86	0.81	7.6	5.3	2.60	3.20	2.60	7.40	6.2		36
2200	2	2840	50	230	7.88	0.86	0.81	7.6	5.3	2.60	3.20	2.60	7.40	6.2	21	

$P_N$	= Rated power	$I_S/I_N$	= Ratio of startup current – rated current
$n_p$	= Number of poles	$M_S/M_N$	= Ratio of startup torque – rated torque
$n_N$	= Rated speed of rotor	$M_B/M_N$	= Ratio of pull-out torque – rated torque
$f_N$	= Rated frequency	$M_P/M_N$	= Ratio of pull-up torque – rated torque
$U_N$	= Rated voltage	$M_N$	= Rated torque of rotor
$I_N$	= Rated current	$R_M$	= Branch resistance
$\cos\varphi$	= Power factor	$U_{SH\Delta}$	= Heater voltage in delta connection
$\eta$	= Efficiency	$U_{SHY}$	= Heater voltage in star connection
$J_R$	= Rotor moment of inertia		

# DRUM MOTOR

## DM SERIES

### DM 0165

Mechanical data for 3-phase asynchronous motor (form-fit belts or without belt)

$P_N$ [W]	$n_p$	gs	i	v [m/s]	$n_A$ [min <sup>-1</sup> ]	$M_A$ [Nm]	$F_N$ [N]	$FW_{MIN}$ [mm]	$SL_{MIN}$ [mm]
306	12	3	46.56	0.083	9.8	280.8	3467	457	450
306	8	3	62.37	0.100	13.5	204.2	2521	407	400
455	6	3	62.37	0.115	13.5	301.9	3727	407	400
455	6	3	46.56	0.154	18.1	225.3	2782	407	400
620	6	3	46.56	0.158	18.6	299.9	3703	457	450
620	4	3	62.37	0.187	22.1	252.3	3114	407	400
620	4	3	46.56	0.251	29.6	188.3	2325	407	400
620	4	3	39.31	0.297	35.1	159.0	1963	407	400
620	4	3	31.56	0.370	43.7	127.6	1576	407	400
620	4	3	24.60	0.475	56.0	99.5	1228	407	400
620	4	2	19.64	0.595	70.2	81.0	1000	407	400
620	4	2	14.66	0.797	94.0	60.5	747	407	400
620	4	2	12.38	0.945	111.4	51.1	630	407	400
909	4	3	46.56	0.240	28.4	288.2	3558	407	400
909	4	3	39.31	0.285	33.6	243.3	3004	407	400
909	4	3	31.56	0.355	41.8	195.3	2411	407	400
909	4	3	24.60	0.455	53.7	152.3	1880	407	400
909	4	2	19.64	0.570	67.2	124.0	1531	407	400
909	4	2	14.66	0.764	90.1	92.6	1143	407	400
909	4	2	12.38	0.905	106.7	78.2	965	407	400
909	2	3	46.56	0.521	61.4	133.0	1642	407	400
909	2	3	39.31	0.617	72.8	112.3	1386	407	400
909	2	3	24.60	0.986	116.3	70.3	868	407	400
909	2	2	19.64	1.235	145.6	57.2	707	407	400
909	2	2	14.66	1.655	195.1	42.7	527	407	400
909	2	2	12.38	1.960	231.1	36.1	445	407	400
909	2	2	9.65	2.514	296.4	28.1	347	407	400
1240	4	3	31.56	0.374	44.1	252.5	3117	457	450
1240	4	3	24.60	0.480	56.6	196.8	2430	457	450
1240	4	2	19.64	0.602	70.9	160.3	1979	457	450
1240	4	2	14.66	0.806	95.0	119.7	1477	457	450
1240	4	2	12.38	0.955	112.6	101.0	1247	457	450

# DRUM MOTOR DM SERIES DM 0165

$P_N$ [W]	$n_p$	gs	i	v [m/s]	$n_A$ [min <sup>-1</sup> ]	$M_A$ [Nm]	$F_N$ [N]	$FW_{MIN}$ [mm]	$SL_{MIN}$ [mm]
1818	2	3	46.56	0.519	61.2	267.0	3296	457	450
1818	2	3	39.31	0.615	72.5	225.4	2783	457	450
1818	2	3	31.56	0.766	90.3	180.9	2234	457	450
1818	2	3	24.60	0.983	115.9	141.1	1741	457	450
1818	2	2	19.94	1.231	145.1	114.9	1418	457	450
1818	2	2	14.66	1.649	194.4	85.8	1059	457	450
1818	2	2	12.38	1.953	230.3	72.4	894	457	450
1818	2	2	9.65	2.505	295.3	56.5	697	457	450

$P_N$	= Rated power	$n_A$	= Shell rated speed
$n_p$	= Number of poles	$M_A$	= Drum motor rated torque
gs	= Gear stages	$F_N$	= Drum motor rated belt pull
i	= Speed ratio	$FW_{MIN}$	= Minimum drum width
v	= Speed	$SL_{MIN}$	= Minimum shell length

# DRUM MOTOR

## DM SERIES

### DM 0165

#### Electrical data for 3-phase asynchronous motor (form-fit belts or without belt)

$P_N$ [W]	$n_p$	$n_N$ [min <sup>-1</sup> ]	$f_N$ [Hz]	$U_N$ [V]	$I_N$ [A]	$\cos\varphi$	$\eta$ [%]	$J_R$ [kgcm <sup>2</sup> ]	$I_s/I_N$	$M_s/M_N$	$M_B/M_N$	$M_P/M_N$	$M_N$ [Nm]	$R_M$ [Ω]	$U_{SH\Delta}$ [V]	$U_{SHY}$ [V]
306	12	456	50	400	1.45	0.62	0.49	35.1	1.80	1.74	1.98	1.57	6.41	22.4		30.0
306	12	456	50	230	2.51	0.62	0.49	35.1	1.80	1.74	1.98	1.57	6.41	22.4	17.0	
306	8	690	50	400	1.15	0.62	0.62	22.6	2.90	1.24	1.40	1.16	3.48	28.0		30.0
306	8	690	50	230	1.97	0.62	0.62	22.6	2.90	1.24	1.40	1.16	3.48	28.0	17.0	
455	6	845	50	400	1.18	0.75	0.74	22.60	3.10	1.07	1.07	1.07	5.14	25.0		33.0
455	6	845	50	230	2.40	0.75	0.74	22.60	3.10	1.07	1.07	1.07	5.14	25.0	19.0	
620	6	865	50	400	1.91	0.78	0.60	22.60	3.20	1.17	1.20	1.16	6.85	6.2		14.0
620	6	865	50	230	3.30	0.78	0.60	22.60	3.20	1.17	1.20	1.16	6.85	6.2	8.0	
620	4	1378	50	400	1.48	0.80	0.76	11.30	3.60	1.26	1.49	1.07	4.30	14.4		36.0
620	4	1378	50	230	2.55	0.80	0.76	11.30	3.60	1.26	1.49	1.07	4.30	14.4	21.0	
909	4	1320	50	400	2.27	0.84	0.69	11.30	3.70	1.16	1.24	1.07	6.58	8.3		24.0
909	4	1320	50	230	3.92	0.84	0.69	11.30	3.70	1.16	1.24	1.07	6.58	8.3	14.0	
909	2	2860	50	400	1.91	0.86	0.80	7.30	4.60	2.48	2.64	1.74	3.04	6.2		15.0
909	2	2860	50	230	3.30	0.86	0.80	7.30	4.60	2.48	2.64	1.74	3.04	6.2	9.0	
1240	4	1393	50	400	2.86	0.80	0.78	19.80	3.50	1.18	1.21	1.07	8.50	6.2		21.0
1240	4	1393	59	230	4.94	0.80	0.78	19.80	3.50	1.18	1.21	1.07	8.50	6.2	12.0	
1818	2	2850	50	400	3.73	0.85	0.83	7.60	4.80	2.07	2.31	1.65	6.09	6.2		29.0
1818	2	2850	50	230	6.43	0.85	0.83	7.60	4.80	2.07	2.31	1.65	6.09	6.2	17.0	

$P_N$  = Rated power  
 $n_p$  = Number of poles  
 $n_N$  = Rated speed of rotor  
 $f_N$  = Rated frequency  
 $U_N$  = Rated voltage  
 $I_N$  = Rated current  
 $\cos\varphi$  = Power factor  
 $\eta$  = Efficiency  
 $J_R$  = Rotor moment of inertia

$I_s/I_N$  = Ratio of startup current – rated current  
 $M_s/M_N$  = Ratio of startup torque – rated torque  
 $M_B/M_N$  = Ratio of pull-out torque – rated torque  
 $M_P/M_N$  = Ratio of pull-up torque – rated torque  
 $M_N$  = Rated torque of rotor  
 $R_M$  = Branch resistance  
 $U_{SH\Delta}$  = Heater voltage in delta connection  
 $U_{SHY}$  = Heater voltage in star connection

## Belt tension diagrams

### Belt tension depending on drum width

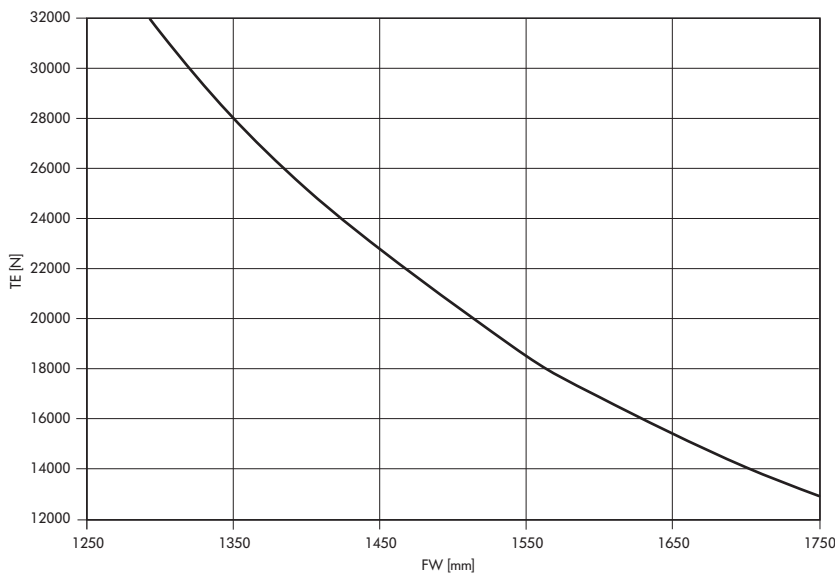

### Belt tension depending on rated speed of shell

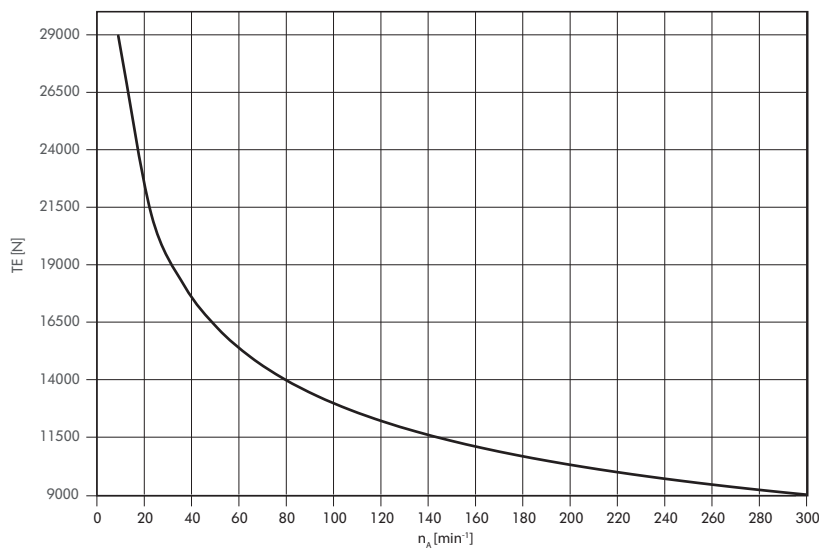

**Note:** The correct value for the maximum permissible belt tension is determined from the speed of the drum motor. When selecting the motor, also check whether the maximum permissible TE value fits the desired drum width (FW). The belt tension diagrams apply only to standard shafts.

- TE = Belt tension
- n<sub>A</sub> = Shell rated speed
- FW = Drum width

# DRUM MOTOR

## DM SERIES

### DM 0165

#### Dimensions

#### Drum motor

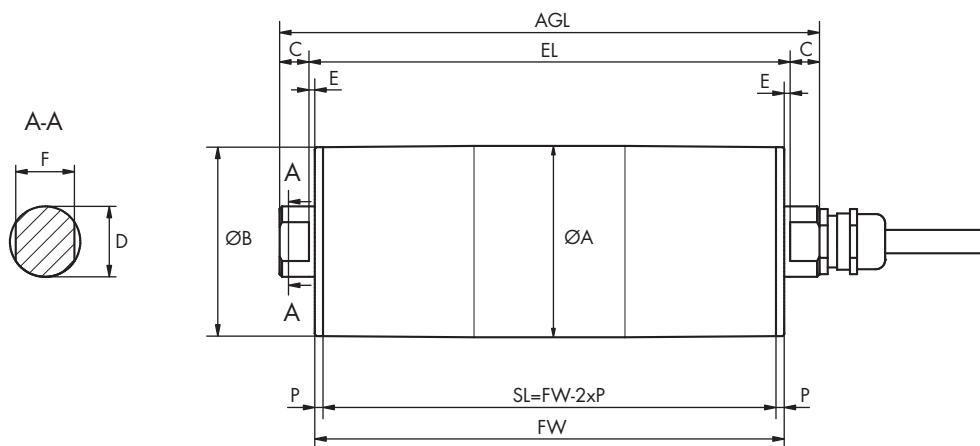

Type		A [mm]	B [mm]	C [mm]	D [mm]	S [mm]	F [mm]	P [mm]	SL [mm]	EL [mm]	AGL [mm]
<b>DM 0165 crowned</b>	Standard	164	162	25	30	16.5	25	3.5	FW - 7	FW + 33	FW + 83
	Optional	164	162	45	40	16.5	30	3.5	FW - 7	FW + 33	FW + 123
<b>DM 0165 cylindrical</b>	Standard	162	162	25	30	16.5	25	3.5	FW - 7	FW + 33	FW + 83
	Optional	162	162	45	40	16.5	30	3.5	FW - 7	FW + 33	FW + 123
<b>DM 0165 cylindrical + key</b>	Standard	162	162	25	30	16.5	25	3.5	FW - 7	FW + 33	FW + 83
	Optional	162	162	45	40	16.5	30	3.5	FW - 7	FW + 33	FW + 123



**DRUM MOTOR  
DM SERIES  
DM 0165**



DL series

**DM series**

DP series

Application notes

# DRUM MOTOR

## DM SERIES

### DM 0217



Practice-oriented, scalable and thought out in detail: The new drum motor DM 0217 makes it easy to build a completely individual conveyor system and is dimensioned for the higher requirements of permissible belt tension now demanded from industry and belt manufacturers alike.

With a broader speed spectrum, the DM 0217 covers all possible applications. The clever plug-and-play connection significantly simplifies the installation. Each motor is approved, tested, and modularized so that it can be produced and delivered around the world in the shortest amount of time.

The modular design of the DM 0217 allows a free combination of individual module groups, such as shaft, end housing, shell or steel gear, to perfectly meet the requirements of an application. In addition, various options, such as encoder, brake, backstop, rubber laggings, etc., as well as different accessories are available.

With the platform concept of the DM 0217, it is possible to cover all internal logistics applications in the food processing sector, as well as in industry, distribution and airports.



## Technical data

	Asynchronous squirrel cage motor
Insulation class of motor windings	Class F, IEC 34 (VDE 0530)
Voltage	230/400 V $\pm 5\%$ (IEC 34/38) Most of the common international voltages and frequencies are available upon request
Frequency	50 Hz
Shaft seal, internal	NBR
Protection rate Motor*	IP69K
Thermal controller	Bi-metal switch
Operating mode	S1
Ambient temperature, 3-phase motor	+2 to +40 °C Low temperature ranges on request.
Ambient temperature, 3-phase motor for applications with form-fit belts or no belt	+2 to +25 °C

\* The protection rate of the cable connector may deviate.

## Design variants and accessories

Lagging	Lagging for friction drive belts Lagging for modular plastic belts Lagging for positive drive solid homogeneous belts
Sprockets	Sprockets only on request
Options	Backstop Electromagnetic holding brake and rectifier* Encoder* Balancing Plug connection (up to max. 1100 W)
Oils	Food-grade oils (EU, FDA, NSF H1)
Certificate	cULus safety certificates
Accessories	Idler pulleys; conveyor rollers; mounting brackets; cables; inverters

\* Depending on the option, the motor extends by 50 mm.

# DRUM MOTOR

## DM SERIES

### DM 0217

#### Material variants

The following components can be selected for the drum motor and the electrical connection. The combination of components depends on the material used.

Component	Version	Aluminum	Mild steel	Stainless steel	Brass/nickel	Technopolymer
<b>Shell</b>	Crowned		●	●		
	Cylindrical		●	●		
	Cylindrical + key		●	●		
<b>End housing</b>	Standard	●		●		
<b>Shaft</b>	Standard			●		
	Cross-drilled thread			●		
<b>Gear boxes</b>	Spur gear box		●			
<b>Electrical connector</b>	Straight connector			●	●	●
	Straight hygienic connector			●		
	Elbow connector			●		●
	Terminal box	●		●		●
	90° hygienic connector			●		
<b>Motor winding</b>	Asynchronous motor					
<b>External seal</b>	PTFE					

#### Motor variants

##### Mechanical data for 3-phase asynchronous motor

$P_N$ [W]	$n_p$	gs	i	v [m/s]	$n_A$ [min <sup>-1</sup> ]	$M_A$ [Nm]	$F_N$ [N]	$FW_{MIN}$ [mm]	$SL_{MIN}$ [mm]
370	8	3	62.37	0.126	11.1	300.6	2764	410	400
550	6	3	62.37	0.154	13.5	365.2	3358	410	400
550	6	3	46.56	0.207	18.1	272.6	2506	410	400
750	4	3	62.37	0.247	21.7	310.6	2856	410	400
1100	8	2	31.11	0.254	22.3	451.8	4154	410	500
1100	4	3	46.56	0.323	28.4	348.8	3207	410	400
1100	4	3	39.31	0.382	33.62	294.5	2708	410	400
1100	4	3	31.56	0.476	41.8	263.4	2174	410	400
1100	4	3	24.60	0.611	53.7	184.3	1695	410	400
1100	4	2	19.64	0.766	67.2	150.1	1380	410	400

# DRUM MOTOR DM SERIES DM 0217

$P_N$ [W]	$n_p$	gs	i	v [m/s]	$n_A$ [min <sup>-1</sup> ]	$M_A$ [Nm]	$F_N$ [N]	$FW_{MIN}$ [mm]	$SL_{MIN}$ [mm]
1100	4	2	14.66	1.026	90.1	112.1	1030	410	400
1100	4	2	12.38	1.215	106.7	94.6	870	410	400
1100	2	3	24.60	1.317	115.7	85.4	786	410	400
1100	2	2	19.64	1.650	144.9	69.6	640	410	400
1100	2	2	14.66	2.211	194.1	51.9	478	410	400
1100	2	2	12.38	2.618	229.9	43.9	403	410	400
1100	2	2	9.65	3.357	294.8	34.2	314	410	400
1500	6	2	27.53	0.397	34.9	394.5	3628	510	500
1500	4	2	31.11	0.516	45.3	303.6	2791	510	550
1500	4	2	27.53	0.583	51.2	268.7	2470	510	500
1500	4	2	20.10	0.799	70.1	196.2	1804	510	500
1500	4	2	16.80	0.956	83.9	163.9	1507	510	500
2200	4	2	31.11	0.520	45.6	442.2	4066	510	500
2200	4	2	27.53	0.587	51.6	391.4	3599	510	500
2200	4	2	20.10	0.804	70.6	285.7	2627	510	500
2200	4	2	16.80	0.963	84.5	238.8	2196	510	500
2200	2	2	27.53	1.156	101.5	198.9	1829	510	500
2200	2	2	20.10	1.583	139.0	145.2	1335	510	500
2200	2	2	16.80	1.894	166.3	121.3	1116	510	500
3000	4	2	27.53	0.587	51.6	533.6	4907	510	500
3000	4	2	20.10	0.804	70.6	389.6	3583	510	500
3000	4	2	16.80	0.963	84.5	325.6	2994	510	500
3000	2	2	27.53	1.163	102.1	269.5	2478	510	500
3000	2	2	20.10	1.593	139.9	196.7	1809	510	500
3000	2	2	16.80	1.906	167.4	164.4	1512	510	500

$P_N$  = Rated power  
 $n_p$  = Number of poles  
 gs = Gear stages  
 i = Speed ratio  
 v = Speed

$n_A$  = Shell rated speed  
 $M_A$  = Drum motor rated torque  
 $F_N$  = Drum motor rated belt pull  
 $FW_{MIN}$  = Minimum drum width  
 $SL_{MIN}$  = Minimum shell length

DL series

DM series

DP series

Application notes

# DRUM MOTOR

## DM SERIES

### DM 0217

#### Electrical data for 3-phase asynchronous motor

$P_N$ [W]	$n_p$	$n_N$ [min <sup>-1</sup> ]	$f_N$ [Hz]	$U_N$ [V]	$I_N$ [A]	$\cos\varphi$	$\eta$ [%]	$J_R$ [kgcm <sup>2</sup> ]	$I_S/I_N$	$M_S/M_N$	$M_B/M_N$	$M_P/M_N$	$M_N$ [Nm]	$R_M$ [Ω]	$U_{SH\Delta}$ [V]	$U_{SHY}$ [V]
370	8	690	50	400	1.50	0.62	0.57	22.6	2.87	1.90	2.35	1.90	5.12	22.0		31
370	8	690	50	230	2.42	0.62	0.57	22.6	2.87	1.90	2.35	1.90	5.12	22.0	17	
550	6	845	50	400	1.60	0.69	0.72	22.6	3.4	1.40	1.65	1.40	6.22	19.5		32
550	6	845	50	230	2.77	0.69	0.72	22.6	3.4	1.40	1.65	1.40	6.22	19.5	19	
750	4	1355	50	400	1.80	0.80	0.75	11.3	3.5	1.53	1.80	1.30	5.29	23.9		52
750	4	1355	50	230	3.12	0.80	0.75	11.3	3.5	1.53	1.80	1.30	5.29	23.9	30	
1100	2	2845	50	400	2.40	0.86	0.77	7.6	5.2	3.15	3.42	2.10	3.69	2.9		9
1100	2	2845	50	230	4.16	0.86	0.77	7.6	5.2	3.15	3.42	2.10	3.69	2.9	5	
1100	4	1320	50	400	2.80	0.82	0.69	11.3	3.5	1.50	1.70	1.30	7.96	7.2		25
1100	4	1320	50	230	4.85	0.82	0.69	11.3	3.5	1.50	1.70	1.30	7.96	7.2	14	
1100	8	695	50	400	3.20	0.81	0.61	86.0	4.5	1.80	2.20	1.70	15.12	6.3		24
1100	8	695	50	230	5.54	0.81	0.61	86.0	4.5	1.80	2.20	1.70	15.12	6.3	14	
1500	6	960	50	400	4.00	0.82	0.66	86.0	4.8	2.10	2.50	1.90	14.92	4.3		21
1500	6	960	50	230	6.93	0.82	0.66	86.0	4.8	2.10	2.50	1.90	14.92	4.3	12	
1500	4	1410	50	400	3.70	0.87	0.67	49.6	5.5	2.20	2.50	1.80	10.16	3.6		17
1500	4	1410	50	230	6.41	0.87	0.67	49.6	5.5	2.20	2.50	1.80	10.16	3.6	10	
2200	4	1420	50	400	5.20	0.87	0.70	60.0	5.9	2.40	2.90	2.30	14.80	3.55		24
2200	4	1420	50	230	9.01	0.87	0.70	60.0	5.9	2.40	2.90	2.30	14.80	3.55	14	
2200	2	2794	50	400	5.10	0.88	0.71	26.0	6.4	2.60	3.02	2.30	7.52	2.95		20
2200	2	2794	50	230	8.83	0.88	0.71	26.0	6.4	2.60	3.02	2.30	7.52	2.95	11	
3000	4	1420	50	400	7.00	0.82	0.76	46.9	5.0	2.40	2.90	2.30	20.19	1.85		16
3000	4	1420	50	230	12.12	0.82	0.76	46.9	5.0	2.40	2.90	2.30	20.19	1.85	9	
3000	2	2812	50	400	6.65	0.82	0.80	37.1	6.5	2.60	3.40	2.40	10.19	1.55		13
3000	2	2812	50	230	11.52	0.82	0.80	37.1	6.5	2.60	3.40	2.40	10.19	1.55	7	

$P_N$  = Rated power  
 $n_p$  = Number of poles  
 $n_N$  = Rated speed of rotor  
 $f_N$  = Rated frequency  
 $U_N$  = Rated voltage  
 $I_N$  = Rated current  
 $\cos\varphi$  = Power factor  
 $\eta$  = Efficiency  
 $J_R$  = Rotor moment of inertia

$I_S/I_N$  = Ratio of startup current – rated current  
 $M_S/M_N$  = Ratio of startup torque – rated torque  
 $M_B/M_N$  = Ratio of pull-out torque – rated torque  
 $M_P/M_N$  = Ratio of pull-up torque – rated torque  
 $M_N$  = Rated torque of rotor  
 $R_M$  = Branch resistance  
 $U_{SH\Delta}$  = Heater voltage in delta connection  
 $U_{SHY}$  = Heater voltage in star connection

# DRUM MOTOR DM SERIES DM 0217

## Mechanical data for 3-phase asynchronous motor (form-fit belts or without belt)

$P_N$ [W]	$n_p$	gs	i	v [m/s]	$n_A$ [min <sup>-1</sup> ]	$M_A$ [Nm]	$F_N$ [N]	$FW_{MIN}$ [mm]	$SL_{MIN}$ [mm]
306	8	3	62.37	0.100	13.5	204.2	2521	407	400
455	6	3	62.37	0.115	13.5	301.9	3727	407	400
455	6	3	46.56	0.154	18.1	225.3	2782	407	400
620	4	3	62.37	0.187	22.1	252.3	3114	407	400
909	4	3	46.56	0.240	28.4	288.2	3558	407	400
909	4	3	39.31	0.285	33.6	243.3	3004	407	400
909	4	3	31.56	0.355	41.8	195.3	2411	407	400
909	4	3	24.60	0.455	53.7	152.3	1880	407	400
909	4	2	19.64	0.570	67.2	124.0	1531	407	400
909	4	2	14.66	0.764	90.1	92.6	1143	407	400
909	4	2	12.38	0.905	106.7	78.2	965	407	400
909	2	3	24.60	0.986	116.3	70.3	868	407	400
909	2	2	19.64	1.235	145.6	57.2	707	407	400
909	2	2	14.66	1.655	195.1	42.7	527	407	400
909	2	2	12.38	1.960	231.1	36.1	445	407	400
909	2	2	9.65	2.514	296.4	28.1	347	407	400

$P_N$	= Rated power	$n_A$	= Shell rated speed
$n_p$	= Number of poles	$M_A$	= Drum motor rated torque
gs	= Gear stages	$F_N$	= Drum motor rated belt pull
i	= Speed ratio	$FW_{MIN}$	= Minimum drum width
v	= Speed	$SL_{MIN}$	= Minimum shell length

# DRUM MOTOR

## DM SERIES

### DM 0217

Electrical data for 3-phase asynchronous motor (form-fit belts or without belt)

$P_N$ [W]	$n_p$	$n_N$ [min <sup>-1</sup> ]	$f_N$ [Hz]	$U_N$ [V]	$I_N$ [A]	$\cos\varphi$	$\eta$ [%]	$J_R$ [kgcm <sup>2</sup> ]	$I_S/I_N$	$M_S/M_N$	$M_B/M_N$	$M_P/M_N$	$M_N$ [Nm]	$R_M$ [Ω]	$U_{SH\Delta}$ [V]	$U_{SHY}$ [V]
306	8	840	50	230	1.97	0.62	0.62	22.6	2.9	1.24	1.40	1.16	3.48	28.0	17	
306	8	840	50	400	1.15	0.62	0.62	22.6	2.9	1.24	1.40	1.16	3.48	28.0		30
455	6	845	50	230	2.04	0.75	0.74	22.6	3.1	1.07	1.07	1.07	5.14	25.0	19	
455	6	845	50	400	1.18	0.75	0.74	22.6	3.1	1.07	1.07	1.07	5.14	25.0		33
620	4	1378	50	230	2.55	0.80	0.76	11.3	3.6	1.26	1.49	1.07	4.30	14.4	15	
620	4	1378	50	400	1.48	0.80	0.76	11.3	3.6	1.26	1.49	1.07	4.30	14.4		26
909	4	1320	50	230	3.92	0.84	0.69	11.3	3.7	1.16	1.24	1.07	6.58	8.3	14	
909	4	1320	50	400	2.27	0.84	0.69	11.3	3.7	1.16	1.24	1.07	6.58	8.3		24
909	2	2860	50	230	3.30	0.86	0.80	7.3	4.6	2.48	2.64	1.74	3.04	6.2	9	
909	2	2860	50	400	1.91	0.86	0.80	7.3	4.6	2.48	2.64	1.74	3.04	6.2		15

$P_N$  = Rated power  
 $n_p$  = Number of poles  
 $U_N$  = Rated voltage  
 $I_N$  = Rated current  
 $\cos\varphi$  = Power factor  
 $\eta$  = Efficiency  
 $J_R$  = Rotor moment of inertia  
 $I_S/I_N$  = Ratio of startup current –  
 rated current

$M_S/M_N$  = Ratio of startup torque – rated torque  
 $M_B/M_N$  = Ratio of pull-out torque – rated torque  
 $M_P/M_N$  = Ratio of pull-up torque – rated torque  
 $M_N$  = Rated torque of rotor  
 $R_M$  = Branch resistance  
 $U_{SH\Delta}$  = Heater voltage in delta connection  
 $U_{SHY}$  = Heater voltage in star connection



## Belt tension diagrams

### Belt tension depending on rated speed of shell

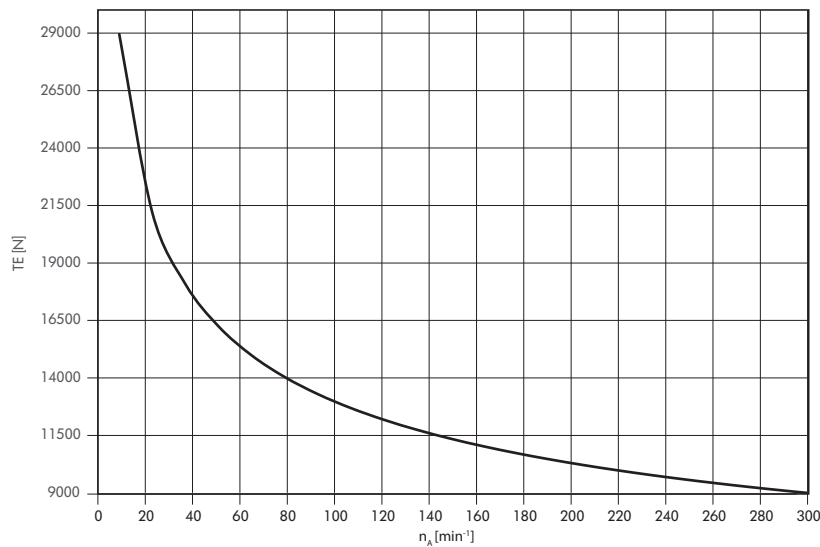

**Note:** The correct value for the maximum permissible belt tension is determined from the maximum permissible TE value for the rpm of the drum motor. The TE value for the shell length does not have to be taken into account for the standard motor DM 0217. The belt tension diagrams apply only to standard shafts.

- TE = Belt tension
- $n_A$  = Shell rated speed
- FW = Drum width

# DRUM MOTOR

## DM SERIES

### DM 0217

#### Dimensions

#### Drum motor

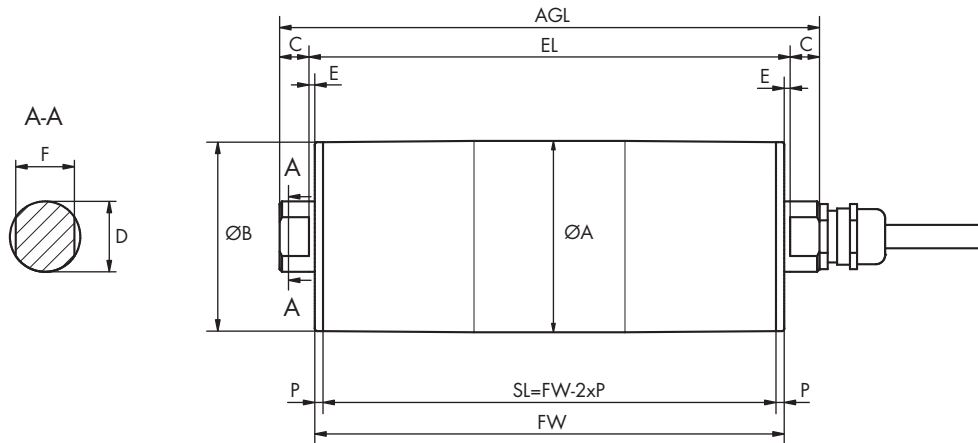

Type		A [mm]	B [mm]	C [mm]	D [mm]	S [mm]	F [mm]	P [mm]	SL [mm]	EL [mm]	AGL [mm]
<b>DM 0217 crowned</b>	Standard	217.5	215.5	45	30	16.5	25	5	FW - 10	FW + 33	FW + 123
	Optional	217.5	215.5	45	40	16.5	30	5	FW - 10	FW + 33	FW + 123
<b>DM 0217 cylindrical</b>	Standard	215.5	215.5	45	30	16.5	25	5	FW - 10	FW + 33	FW + 123
	Optional	215.5	215.5	45	40	16.5	30	5	FW - 10	FW + 33	FW + 123
<b>DM 0217 cylindrical + key</b>	Standard	215.5	215.5	45	30	16.5	25	5	FW - 10	FW + 33	FW + 123
	Optional	215.5	215.5	45	40	16.5	30	5	FW - 10	FW + 33	FW + 123

**DRUM MOTOR  
DM SERIES  
DM 0217**



DL series

**DM series**

DP series

Application notes

# DM SERIES LAGGING AND COATING LAGGING

For friction drive belt applications



## Hygienic and loadable

A lagging provides an advantage for drum motors, particularly for wet applications and in food processing, with its typical hygienic requirements. A lagging increases the friction between drum motor and conveyor belt, thereby preventing slippage. On top of that, it is resistant to external influences such as oil, fuels, and other chemicals that may be used for cleaning. Depending on the application, different profiles are available: For high volumes of liquid, a longitudinal grooved lagging redirects moisture between belt and motor, a center V-groove provides space for a tracking profile. Laggings are available in cold and hot vulcanization, whereby the latter meets particularly strict hygiene requirements.

**Note:** It is important to incorporate a calculation of belt pull and speed that is adjusted to the greater outer diameter of the drum motor.



# DM SERIES LAGGING AND COATING LAGGING

For friction drive belt applications

## Technical data

<b>Material</b>	Hot or cold-vulcanized NBR, other materials upon request.
<b>Temperature range</b>	-40 to +120 °C
<b>Shore hardness</b>	65 and 70 ± 5 Shore A

## Versions

### Cold vulcanization

Lagging profile	Color	Features	Shore hardness	Thickness [mm]
Smooth	Black	Oil- and grease-resistant	65 ± 5 Shore A	3; 4
	White	FDA food approved	70 ± 5 Shore A	
Longitudinal grooves	White	FDA food approved	70 ± 5 Shore A	8
Diamond patterned	Black	Oil- and grease-resistant	70 ± 5 Shore A	8

### Hot vulcanization

Lagging profile	Color	Features	Shore hardness	Thickness [mm]
Smooth	Black	Oil- and grease-resistant	65 ± 5 Shore A	2; 3; 4; 5; 6; 8; 10; 12; 14; 16
	White/blue	FDA food approved EC1935/2004 approved	70 ± 5 Shore A	
Longitudinal grooves	Black	Oil- and grease-resistant	65 ± 5 Shore A	6; 8; 10; 12; 14; 16
	White/blue	FDA food approved EC1935/2004 approved	70 ± 5 Shore A	
Diamond patterned	Black	Oil- and grease-resistant	65 ± 5 Shore A	6; 8; 10; 12; 14; 16
	White/blue	FDA food approved EC1935/2004 approved	70 ± 5 Shore A	
V-groove	Black	Oil- and grease-resistant	65 ± 5 Shore A	6; 8; 10; 12; 14; 16
	White/blue	FDA food approved EC1935/2004 approved	70 ± 5 Shore A	

# DM SERIES LAGGING AND COATING LAGGING

For friction drive belt applications

## Dimensions

### Smooth

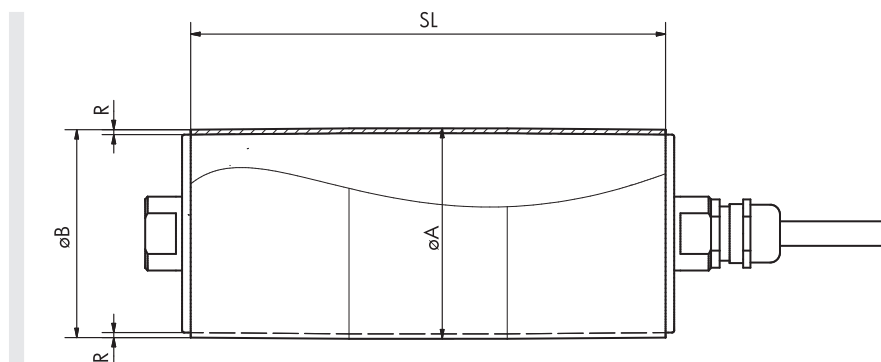

The standard cambers of the lagging are available in the following table.

Drum motor	Ø Tube [mm]	Cold vulcanization			Hot vulcanization		
		Min./max. R [mm]	Ø A [mm]	Ø B [mm]	Min./max. R [mm]	Ø A [mm]	Ø B [mm]
DM 0080	81.5	3	87.5	86.5	2	85.5	84.0
		4	89.5	88.5	6	93.5	92.0
DM 0080 oil-free	81.5				2	85.5	84.5
					16	113.5	112.5
DM 0113	113.5	3	119.5	118	2	117.5	116
		4	121.5	120	16	145.5	144
DM 0113 oil-free	113.5				2	117.5	116
					16	145.5	144
DM 0138	138	3	144	142	2	142	140
		4	146	144	16	170	168
DM 0165	164	3	170	168	2	168	166
		4	172	170	16	196	194
DM 0217	217.5	3	223.5	221.5	2	221.5	219.5
		4	225.5	223.5	16	249.5	247.5

# DM SERIES LAGGING AND COATING LAGGING

For friction drive belt applications

## Diamond patterned

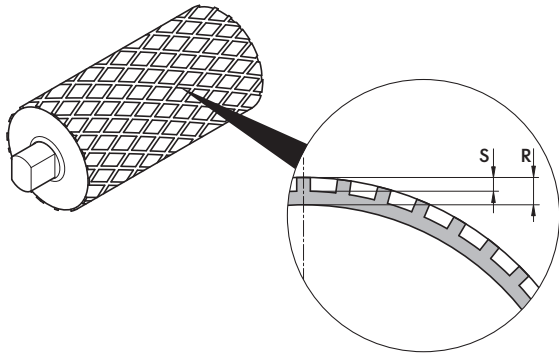

S [mm]	R, cold vulcanization [mm]	R, hot vulcanization [mm]
4	8	6, 8, 10, 12, 14, 16

## V-groove hot vulcanization

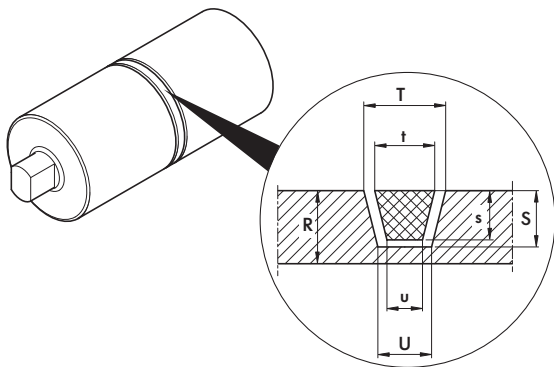

Groove	R Standard [mm]	R Option [mm]	Groove			Belt		
			T [mm]	U [mm]	S [mm]	t [mm]	u [mm]	s [mm]
K6	8	6	10	8	5	6	4	4
K8	8	6	12	8	6	8	5	5
K10	10	8	14	10	7	10	6	6
K13	12	10	17	11	9	13	7.5	8
K15	12	10	19	13	9	15	9.5	8
K17	14	12	21	13	12	17	9.5	11

# DM SERIES LAGGING AND COATING LAGGING

For modular plastic belt applications



### Hygienic, quiet and long lifespan

Based on the specifications of the specific belt manufacturer, up to 38 teeth mesh with the profile of the most common modular plastic belts. The lagging made of hot-vulcanized NBR is suitable for applications in food processing with high hygienic requirements: Easy to clean and extremely resistant to oil, grease and chemicals. Furthermore, it ensures smooth running and provides a long lifespan of the belt due to its low abrasion.

**Note:** It is important to incorporate a calculation of belt pull and speed that is adjusted to the greater outer diameter of the drum motor. Please refer to the velocity factor (VF) in the table on page 113.





# DM SERIES LAGGING AND COATING LAGGING

For modular plastic belt applications

## Technical data

<b>Material</b>	Hot vulcanized NBR
<b>Temperature range</b>	-40 to +120 °C
<b>Shore hardness</b>	70 ± 5 Shore A
<b>Colors</b>	White/blue
<b>Approvals</b>	FDA/EC 1935/2004

## Versions

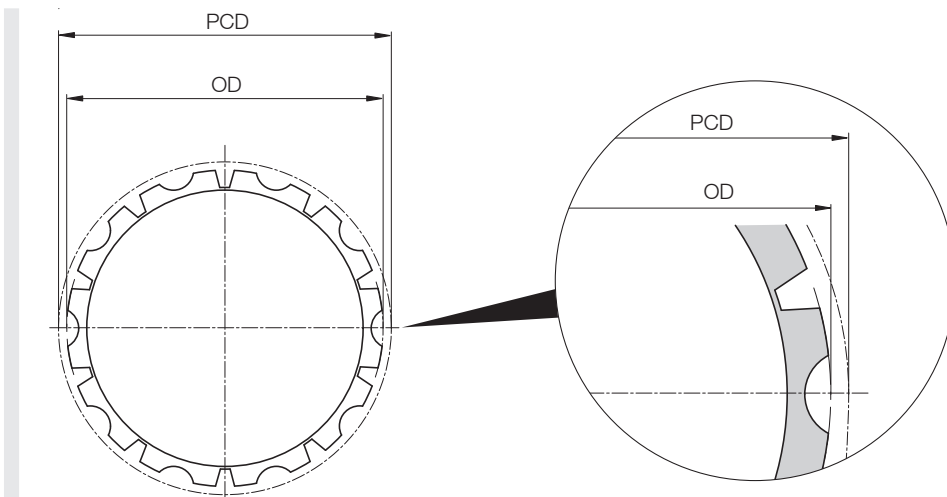

OD = Outer diameter in mm      PCD = Pitch diameter in mm

## Lagging DM 0080 product selection

Belt manufacturer	Series	Lagging DM 0080			
		Z	OD [mm]	PCD [mm]	VF
Ammeraal Beltech/Uni-Chains	HDS60500	24	98.5	97.3	1.21
	HDS61000	12	99.0	98.1	1.22
	HDS62000	7	110.8	114.1	1.42
	CNB	12	98.0	98.5	1.22
	MPB	7	105.5	117.1	1.45
	S-MPB	12	97.9	100.1	1.24
Habasit	M1220/1230/1233/1234 PE/AC	24	92.5	97.3	1.21
	M1220/1230/1233/1234 PP	24	96.0	101.0	1.25
	M2510/M2511/M2514/2516	12	99.4	99.0	1.23

# DM SERIES LAGGING AND COATING LAGGING

For modular plastic belt applications

Belt manufacturer	Series	Lagging DM 0080			
		Z	OD [mm]	PCD [mm]	VF
Intralox	800	7	105.5	116.5	1.45
	1600	13	105.8	105.8	1.31
	1650	13	104.9	105.8	1.31
	1100 FG PE/AC	20	91.0	98.9	1.23
	1100 FG PP	20	91.5	99.5	1.24
	1100 FT PE/AC	20	93.5	97.3	1.21
	1100 FT PP	20	94.0	98.3	1.22
Rexnord	1010	12	97.5	98.1	1.22
Scanbelt	S.25-100 & 600	12	92.2	98.7	1.23
	S.25-800	12	93.6	96.8	1.20
Forbo-Siegling	LM14 Series 4	21	93.0	95.3	1.18
	LM14 Series 2	13	107.0	107.0	1.33
	LM50 Series 6	7	107.5	116.2	1.44

## Lagging DM 0113 product selection

Belt manufacturer	Series	Lagging DM 0113			
		Z	OD [mm]	PCD [mm]	VF
Ammeraal Beltech/Uni-Chains	HDS60500	32	131.0	129.6	1.14
	HDS61000	16	132.0	130.2	1.15
	HDS62000	9	144.2	146.2	1.29
	CNB	16	131.0	130.7	1.15
	MPB	9	140.0	148.5	1.31
	OPB-4	9	144.0	146.2	1.29
	OPB-8	9	139.5	146.2	1.29
	S-MPB	16	132.0	132.3	1.17
	UNI QNB	16	131.2	130.7	1.15
	X-MPB	8	152.0	165.9	1.46
	Habasit	M1220/1230/1233/1234 PE/AC	32	125.0	129.6
M1220/1230/1233/1234 PP		32	128.0	132.6	1.17
M2510/M2511/M2514/2516		16	132.8	131.6	1.16
M5000		9	140.0	149.0	1.31

# DM SERIES LAGGING AND COATING LAGGING

For modular plastic belt applications

Belt manufacturer	Series	Lagging DM 0113			
		Z	OD [mm]	PCD [mm]	VF
Intralox	800	9	140.1	148.5	1.31
	850	9	143.6	148.5	1.31
	1600	16	130.5	130.2	1.15
	1650	16	129.3	130.2	1.15
	1800	8	152.0	165.9	1.46
	1100 FG PE/AC	26	120.6	128.4	1.13
	1100 FG PP	26	121.4	129.1	1.14
	1100 FT PE/AC	27	128.0	131.0	1.15
	1100 FT PP	26	124.0	127.6	1.12
Rexnord	1010	16	130.0	130.2	1.15
	2010	9	138.8	147.9	1.30
Scanbelt	S.25-100 & 600	16	123.0	128.2	1.13
	S.25-800	16	125.8	128.3	1.13
	S.50-100 & 600	9	131.2	146.8	1.29
	S.50-800	9	136.0	146.2	1.29
	S.50-801	9	138.0	139.0	1.22
Forbo-Siegling	LM14 Series 2	16	131.5	131.5	1.16
	LM50 Series 3	9	140.0	146.2	1.29
	LM50 Series 6	9	137.5	146.2	1.29

## Lagging DM 0138 product selection

Belt manufacturer	Series	Lagging DM 0138			
		Z	OD [mm]	PDC [mm]	VF
Ammeraal Beltech/Uni-Chains	HDS60500	38	155.2	153.8	1.11
	HDS61000	19	156.6	154.3	1.12
	HDS62000	10	160.5	161.8	1.17
	CNB	19	155.5	154.9	1.12
	MPB	10	156.6	164.4	1.19
	OPB-4	10	160.0	161.8	1.17
	OPB-8	10	155.5	161.8	1.17
	S-MPB	20	165.0	164.9	1.19
Eurobelt	B50	10	154.0	161.8	1.17

# DM SERIES LAGGING AND COATING LAGGING

For modular plastic belt applications

Belt manufacturer	Series	Lagging DM 0138			
		Z	OD [mm]	PDC [mm]	VF
<b>Habasit</b>	M1220/1230/1233/1234 PE/AC	38	149.5	153.8	1.11
	M1220/1230/1233/1234 PP	38	154.0	158.6	1.15
	M2510/M2511/M2514/2516	20	165.0	163.5	1.18
	M5000	10	158.0	165.7	1.20
<b>Intralox</b>	800	10	156.8	164.4	1.19
	1600	20	163.0	162.4	1.18
	1650	20	162.0	162.4	1.18
	1800	9	174.0	185.7	1.35
	1100 FG PE/AC	32	150.0	157.8	1.14
	1100 FG PP	32	151.0	158.8	1.15
	1100 FT PE/AC	32	152.6	156.0	1.13
	1100 FT PP	32	153.0	156.9	1.14
<b>Rexnord</b>	2010	10	156.8	165.0	1.20
<b>Scanbelt</b>	S.25-100 & 600	19	146.5	151.9	1.10
	S.25-800	20	157.8	159.8	1.16
	S.50-100 & 600	11	164.5	178.2	1.29
	S.50-800	10	155.2	163.9	1.19
	S.50-801	10	155.0	164.0	1.19
<b>Forbo-Siegling</b>	LM50 Series 3	10	157.0	161.8	1.17
	LM50 Series 6	11	170.6	180.0	1.30

## Lagging DM 0165 product selection

Belt manufacturer	Series	Lagging DM 0165			
		Z	OD [mm]	PDC [mm]	VF
<b>Ammeraal Beltech/Uni-Chains</b>	HDS62000	12	193.0	193.3	1.18
	MPB	12	190.0	196.3	1.20
	S-MPB	24	198.0	199.0	1.21
<b>Eurobelt</b>	B50	12	187.0	193.2	1.18
<b>Habasit</b>	M2510/M2511/M2514/2516	23	190.5	189.7	1.16
	M5000	12	190.5	197.2	1.20

# DM SERIES LAGGING AND COATING LAGGING

For modular plastic belt applications

Belt manufacturer	Series	Lagging DM 0165			
		Z	OD [mm]	PDC [mm]	VF
Intralox	800	12	190.0	196.3	1.20
	850	12	187.0	196.3	1.20
	1600	23	187.4	186.5	1.14
	1650	23	186.3	186.4	1.14
	1100 FT PP	38	184.0	186.2	1.14
Scanbelt	S.50-100 & 600	12	179.0	193.0	1.18
	S.50-800	12	185.0	193.2	1.18
	S.50-801	12	185.0	195.6	1.19
Forbo-Siegling	LM50 Series 3	12	189.0	193.2	1.18
	LM50 Series 6	13	205.0	208.9	1.27

## Lagging DM 0217 product selection

Belt manufacturer	Series	Lagging DM 0217			
		Z	OD [mm]	PDC [mm]	VF
Ammeraal Beltech/Uni-Chains	MPB	15	239.0	244.3	1.12
Intralox	800	15	239.0	244.3	1.12
	1600	30	244.3	243.0	1.12
Scanbelt	S.50-100 & 600	16	244.0	256.3	1.18
	S.50-800	15	233.5	240.5	1.11
Forbo-Siegling	LM50 Series 3	16	251.5	256.3	1.18

Z = Number of teeth      PCD = Pitch diameter in mm  
OD = Outer diameter in mm      VF = Velocity factor

**Note:** Only possible for motors of DM series.

If your preferred belt type or manufacturer is not listed here, please contact Interroll.

## DM SERIES LAGGING AND COATING LAGGING

For positive drive solid homogeneous belts



### Hygienic and quiet

The lagging made of Interroll Premium Hygienic PU is suitable for applications in food processing with high hygienic requirements: Easy to clean and extremely resistant to oil, grease and chemicals. Furthermore, it ensures smooth running and provides a long lifespan of the belt due to its low abrasion. This lagging is available for the most common positive drive solid homogeneous belts as well as for motors in applications with positive drive belts.

**Note:** It is important to incorporate a calculation of belt pull and speed that is adjusted to the greater outer diameter of the drum motor. Please refer to the velocity factor (VF) in the table on page 119.



# DM SERIES LAGGING AND COATING LAGGING

For positive drive solid homogeneous belts

## Technical data

<b>Material</b>	Interroll Premium Hygienic PU
<b>Temperature range</b>	-40 to +80 °C
<b>Shore hardness</b>	82 ± 5 Shore D

## Versions

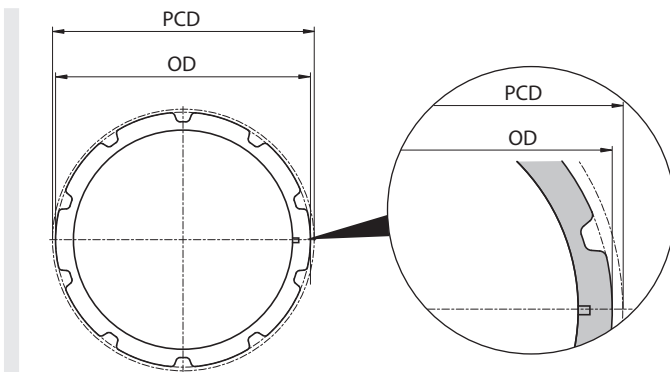

OD = Outer diameter in mm      PCD = Pitch diameter in mm

## Lagging DM 0080 product selection

Belt manufacturer	Series	Lagging DM 0080			
		Z	OD [mm]	PCD [mm]	VF
<b>Intralox</b>	TD 8026 PU (endless)	13	104.2	OD + BT	1.32
<b>Volta</b>	SuperDrive Pulley (H/M)	10	126.4	OD + BT	1.55
	Mini SuperDrive Pulley (H/M)	15	121	OD - BT	1.48
<b>Ammeraal</b>	SoliFlex PRO 2 mm (endless PU-light blue)	7	111	OD + BT	1.39
	SoliFlex PRO 3 mm (endless PU-light blue)	7	111	OD + BT	1.40
<b>Habasit</b>	CD.M25 (endless)	12	100.7	102.7	1.26
	CD.M25 – Lace	12	100.7	102.7	1.26

# DM SERIES

## LAGGING AND COATING

### LAGGING

For positive drive solid homogeneous belts

#### LAGGING DM 0113 product selection

Belt manufacturer	Series	LAGGING DM 0113			
		Z	OD [mm]	PCD [mm]	VF
Intralox	TD 8026 PU (endless)	18	144.3	OD + BT	1.32
	TD 8050 PU (endless)	9	142	145	1.28
Volta	DD 3 mm MW/MB (endless)	9	145.5	148.5	1.31
	SuperDrive Pulley (H/M)	13	164.3	OD + BT	1.45
Habasit	CD.M25 (endless)	16	134.7	136.9	1.21
	CD.M25 – Lace	16	134.7	136.9	1.21
	CD.M50 (endless)	9	142	145	1.28
	CD.M50 – Lace	9	142	145	1.28
Ammeraal	SoliFlex PRO 2 mm (endless PU-light blue)	9	143.5	145.5	1.28
	SoliFlex PRO 3 mm (endless PU-light blue)	9	143.5	146.5	1.29

#### LAGGING DM 0138 product selection

Belt manufacturer	Series	LAGGING DM 0138			
		Z	OD [mm]	PCD [mm]	VF
Intralox	TD 8026 PU (endless)	20	161.5	OD+BT	
	TD 8050 PU (endless)	10	158	161	1.17
Volta	DD 3 mm MW/MB (endless)	10	162	165	1.2
	SuperDrive Pulley (H/M)	15	190	OD + BT	1.37
Habasit	CD.M25 (endless)	20	169	171	1.23
	CD.M25 – Lace	20	169	171	1.23
	CD.M50 (endless)	10	158	161	1.17
	CD.M50 – Lace	10	158	161	1.17
Ammeraal	SoliFlex PRO 2 mm (endless PU-light blue)	10	159.8	161.8	1.17
	SoliFlex PRO 3 mm (endless PU-light blue)	10	159.8	162.8	1.18



# DM SERIES LAGGING AND COATING LAGGING

For positive drive solid homogeneous belts

## Lagging DM 0165 product selection

Belt manufacturer	Series	Lagging DM 0165			
		Z	OD [mm]	PCD [mm]	VF
Intralox	TD 8050 PU (endless)	12	190.2	193.2	1.18
	TD 8050 PU/XT (endless)	12	190.2	193.2	1.18
Volta	SuperDrive Pulley (H/M)	17	215.7	OD + BT	1.32
Habasit	CD.M50 (endless)	12	190.2	193.2	1.18
	CD.M50 – Lace	12	190.2	193.2	1.18
Ammeraal	SoliFlex PRO 3 mm (endless PU-light blue)	12	192.4	195.4	1.19
	SoliFlex PRO 4 mm (endless PU-light blue)	12	192.4	196.4	1.2

Z = Number of teeth                      VF = Velocity factor  
 OD = Outer diameter in mm              BT = Belt thickness  
 PCD = Reference diameter in mm

**Note:** Lace versions cannot be driven with our PU laggings.  
 Only possible for motors of DM series.

If your preferred belt type or manufacturer is not listed here, please contact Interroll.

# DM SERIES

## CABLE OVERVIEW AND CONNECTION DIAGRAMS

### CABLE OVERVIEW

#### Cable overview

#### Cable connections

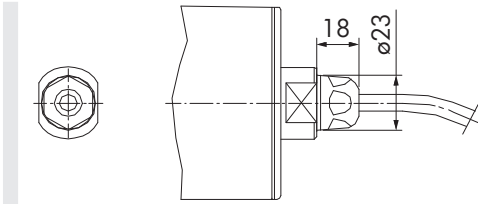

Fig.: Straight hygienic connector, IP69k stainless steel

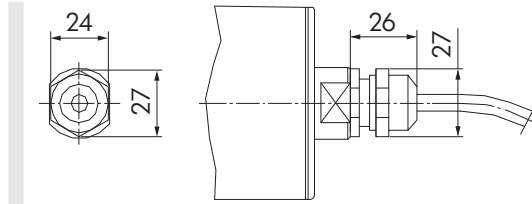

Fig.: Straight connector, brass or stainless steel

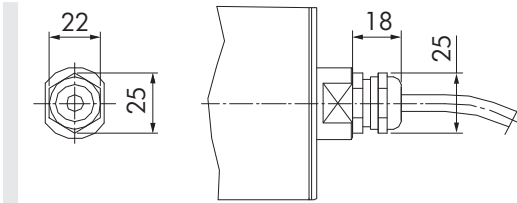

Fig.: Straight EMC connector, brass or stainless steel

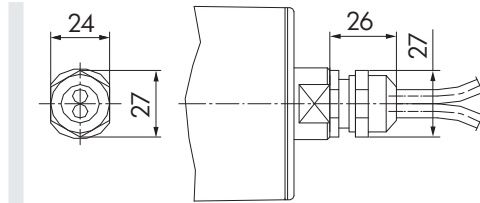

Fig.: Straight connector for encoder, brass or stainless steel

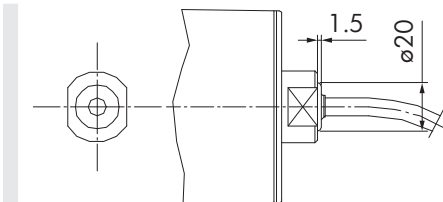

Fig.: Protective cap made of PU

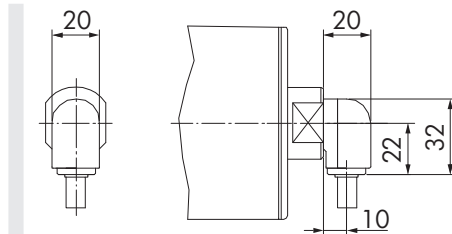

Fig.: Elbow connector, technopolymer

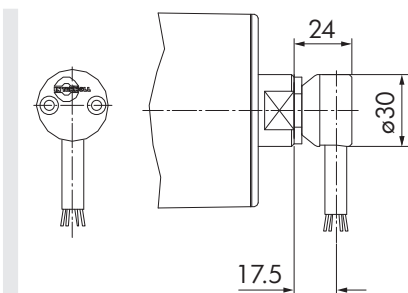

Fig.: Elbow connector, stainless steel, also for encoders

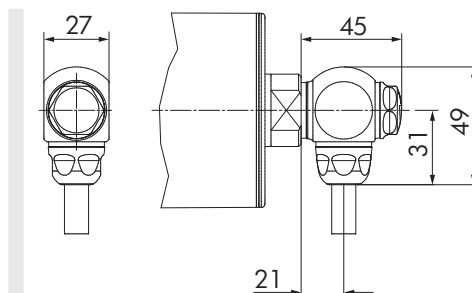

Fig.: 90° hygienic connector, IP69k stainless steel

# DM SERIES CABLE OVERVIEW AND CONNECTION DIAGRAMS CABLE OVERVIEW

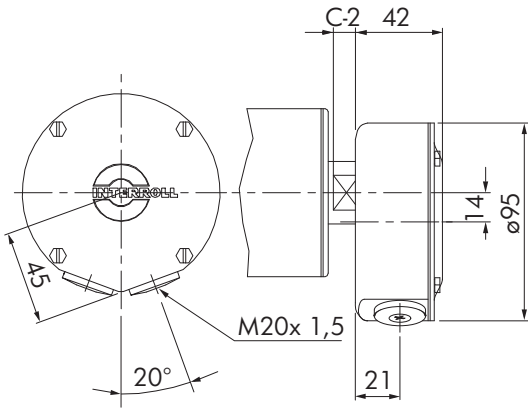

Fig.: Terminal box, stainless steel

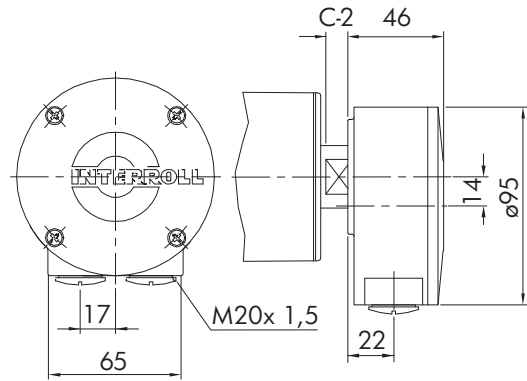

Fig.: Terminal box, aluminum

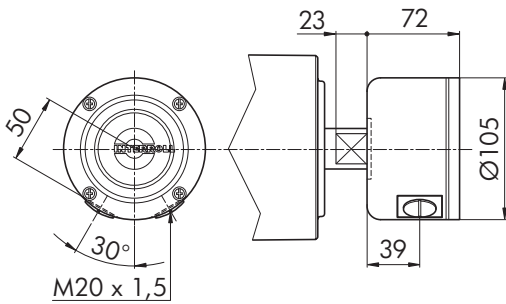

Fig.: Terminal box, technopolymer

Cable specification: Cable types  
Available cable lengths: 1 m, 3 m, 5 m, 10 m

All cable connection dimensions are approximate.

# DM SERIES

## CABLE OVERVIEW AND CONNECTION DIAGRAMS

### CABLE OVERVIEW

#### Plug connection (hygienic design)

The new plug connection is the ideal solution for a quick initial installation and significantly less maintenance effort. Connecting and disconnecting the cables to the motor is simple and can be performed safely and very quickly in just a few steps. Complete disassembly is not needed for motor maintenance or the replacement of a damaged cable. Only the pressing screw and the shell nipple must be loosened and completely unscrewed from the shaft end. Then the connector can easily be pulled out. The assembly is just as simple, in reverse order: The connector engages in the intended position. Then the shell nipple and pressing screw are screwed in and firmly tightened to the block.

#### Technical data

<b>Shaft design</b>	For shaft diameter min. 30 mm and width across flats WAF min. 25 mm
<b>Materials</b>	Stainless steel, TPU seals
<b>Connection</b>	Star/delta configuration with thermal controller contact (shield optional)
<b>Cable lengths</b>	1 m, 3 m, 5 m, 10 m
<b>Delivery</b>	Cable not installed, screw components installed on cable
<b>Electrical data</b>	In compliance with DIN EN 61984
<b>Voltage</b>	230/400 V
<b>Amperage</b>	Max. 5 A
<b>Temperature range</b>	+2 to +40 °C Lower temperatures on request
<b>Protection rate</b>	IP69k after complete assembly
<b>Hygiene requirement</b>	Suitable for cleaning with high-pressure cleaner
<b>Directives</b>	CE certified, EHEDG certified, use of chemicals permissible according to ECOLAB
<b>Mounting tool</b>	Open-end wrench 14 mm and 20 mm

The minimum length of the drum motor with plug connection increases by 59 mm.

# DM SERIES CABLE OVERVIEW AND CONNECTION DIAGRAMS CABLE OVERVIEW

## Dimensions

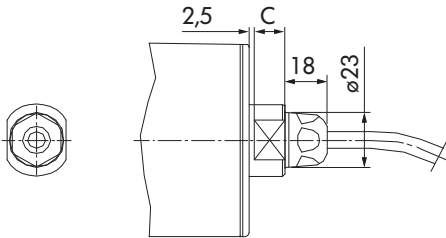

Fig.: Straight plug connection, qualified for hygienic cleaning, IP69k, stainless steel

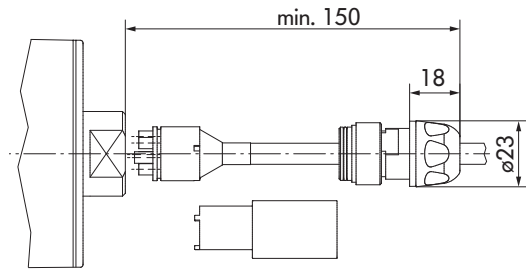

Fig.: Mounting dimensions with a mounting tool

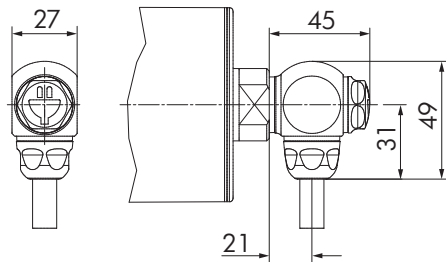

Fig.: 90° plug connection, qualified for hygienic cleaning, IP69k stainless steel

# DM SERIES

## CABLE OVERVIEW AND CONNECTION DIAGRAMS

### CABLE OVERVIEW

#### Cable types of DM series

To reduce EMC emissions, please use a shielded cable for operating the motor via a frequency inverter. No halogen-free cable is available for motors with UL certification or an output over 1500 W. Available cable lengths are 1 m, 3 m, 5 m, and 10 m.

#### Cable with 7 main cores

Article number	1107481	1107478	1107477	1107479	1000569	1118469
<b>Cross section</b>	0.5 mm <sup>2</sup>	0.75 mm <sup>2</sup>	0.75 mm <sup>2</sup>	0.75 mm <sup>2</sup>	0.75 mm <sup>2</sup>	1.3 mm <sup>2</sup>
<b>Numeric code and color code</b>	Numeric code + color code	Numeric code + color code	Numeric code + color code	Numeric code + color code	Numeric code + color code	Numeric code + color code
<b>Insulation conductors (main cores)</b>	ETFE	ETFE	ETFE	PP	PVC	ETFE
<b>Data cores (number)</b>	2	2	2	2	–	2
<b>Cross section</b>	0.5 mm <sup>2</sup>	0.5 mm <sup>2</sup>	0.5 mm <sup>2</sup>	0.5 mm <sup>2</sup>	–	0.5 mm <sup>2</sup>
<b>Numeric code and color code</b>	Color code	Color code	Color code	Color code	–	Color code
<b>Insulation conductors (data cores)</b>	ETFE	ETFE	ETFE	PP	–	ETFE
<b>Insulation of outer sheath</b>	PVC	PVC	PVC	TPU	PVC	PVC
<b>Halogen-free</b>	No	No	No	Yes	No	No
<b>Color of outer sheath</b>	Gray	Gray	Gray	Gray	Black	Gray
<b>Shielded</b>	Copper-tinned	Copper-tinned	–	Copper-tinned	–	Copper-tinned
<b>Outside diameter</b>	7.7 ± 0.2 mm	8.4 ± 0.2 mm	7.3 ± 0.2 mm	8.4 ± 0.2 mm	7.15 ± 0.2 mm	11 ± 0.2 mm
<b>Operating voltage</b>	600 V	600 V	600 V	600 V	300/500 V	600 V
<b>Temperature range</b>	–30 to +105 °C according to UL	–30 to +105 °C according to UL	–30 to +105 °C according to UL	–30 to +105 °C	–30 to +105 °C –40 to +80 °C according to UL	–30 to +105 °C according to UL
<b>Approval</b>	cULus	cULus	cULus	None	cULus	cULus

# DM SERIES

## CABLE OVERVIEW AND CONNECTION DIAGRAMS

### CABLE OVERVIEW

#### Cable with 4 main cores

Article number	1107480	1107482	1118470
Cross section	0.75 mm <sup>2</sup>	0.75 mm <sup>2</sup>	1.3 mm <sup>2</sup>
Numeric code and color code	Numeric code + color code	Numeric code + color code	Numeric code + color code
Insulation conductors (main cores)	ETFE	PP	ETFE
Data cores (number)	2	2	2
Cross section	0.5 mm <sup>2</sup>	0.5 mm <sup>2</sup>	0.5 mm <sup>2</sup>
Numeric code and color code	Color code	Color code	Color code
Insulation conductors (data cores)	ETFE	PP	ETFE
Insulation of outer sheath	PVC	TPU	PVC
Halogen-free	No	Yes	No
Color of outer sheath	Gray	Gray	Gray
Shielded	Copper-tinned	Copper-tinned	Copper-tinned
Outside diameter	7.6 ± 0.2 mm	7.6 ± 0.2 mm	8.0 ± 0.2 mm
Operating voltage	600 V	600 V	600 V
Temperature range	-30 to +105 °C according to UL	-30 to +105 °C	-30 to +105 °C according to UL
Approval	cULus	None	cULus

DL series

DM series

DP series

Application notes

# DM SERIES

## CABLE OVERVIEW AND CONNECTION DIAGRAMS

### CABLE OVERVIEW

#### External plug connection cable types

Article number		Cable length	Plain cable article number	Voltage selection	
Straight design	90° design			Asynchronous motor 230 or 400 V Synchronous motor	Asynchronous motor 230/400 V
61114712	61116487	1 m	1107480	●	
61114713	61116488	3 m	1107480	●	
61114715	61116489	5 m	1107480	●	
61114716	61116490	10 m	1107480	●	
61114280	61116483	1 m	1107482	●	
61114281	61116484	3 m	1107482	●	
61114282	61116485	5 m	1107482	●	
61114283	61116486	10 m	1107482	●	
61114272	61116479	1 m	1107481		●
61114273	61116480	3 m	1107481		●
61114274	61116481	5 m	1107481		●
61114275	61116482	10 m	1107481		●
61114255	61116471	1 m	1107477		●
61114256	61116472	3 m	1107477		●
61114257	61116473	5 m	1107477		●
61114258	61116474	10 m	1107477		●
61114265	61116475	1 m	1107479		●
61114266	61116476	3 m	1107479		●
61114267	61116477	5 m	1107479		●
61114268	61116478	10 m	1107479		●



# DM SERIES

## CABLE OVERVIEW AND CONNECTION DIAGRAMS

### CONNECTION DIAGRAMS

## Connection diagrams

### Abbreviations

ye/gn	= yellow/green	or	= orange
bn	= brown	vi	= violet
bk	= black	rd	= red
gy	= gray	wh	= white
bu	= blue	FC	= Frequency inverter for permanent magnet synchronous motors
TC	= Thermal controller (bi-metal switch)	NC	= Not connected
BR	= Electromagnetic brakes		

### Rotation

**Note:** The rotational direction of the drum motor is shown on the connection diagrams. The rotation indicated is correct when looking at the motor from the connection side.

### Cable connections synchronous motor

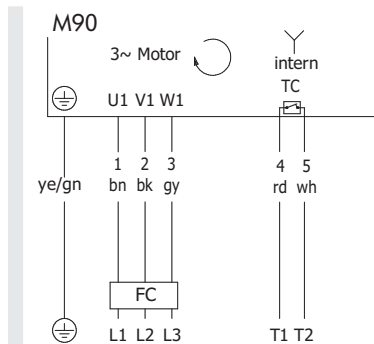

Fig.: 3-phase, 4+2-core cable, winding for 1 voltage, star connection

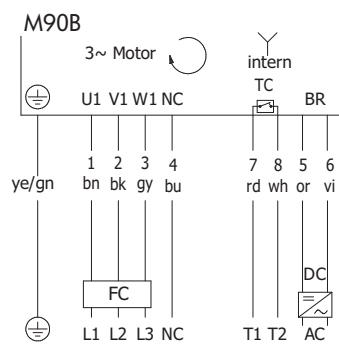

Fig.: 3-phase, 7+2-core cable, winding for 1 voltage, star connection

### Terminal box for synchronous motor

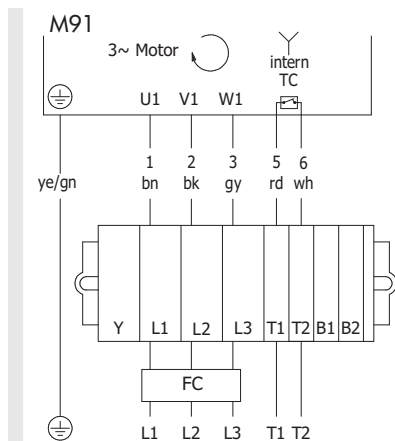

Fig.: 3-phase, 4+2-core cable, winding for 1 voltage, star connection

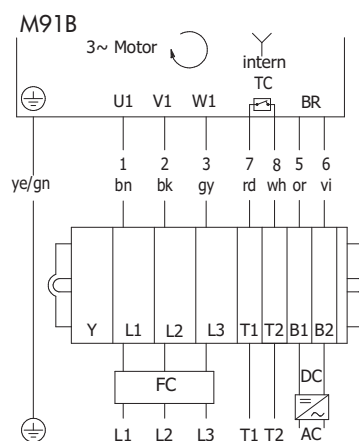

Fig.: With brake, 3-phase, 7+2 core cable, winding for 1 voltage, star connection

# DM SERIES

## CABLE OVERVIEW AND CONNECTION DIAGRAMS

### CONNECTION DIAGRAMS

#### Cable connections 3-phase asynchronous motor

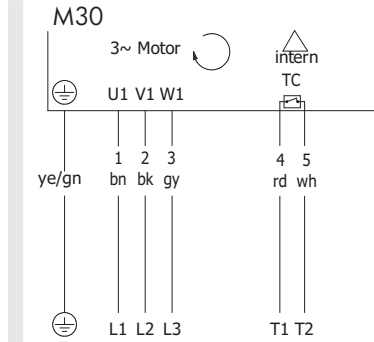

Fig.: 3-phase, 4+2 core cable, winding for 1 voltage, delta connection

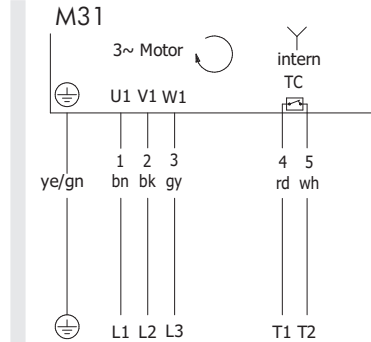

Fig.: 3-phase, 4+2-core cable, winding for 1 voltage, star connection

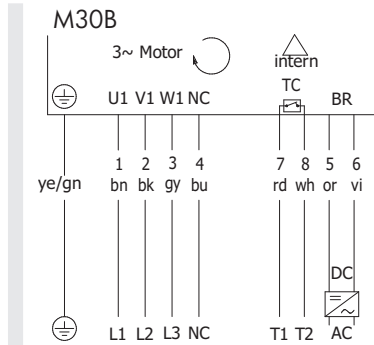

Fig.: With brake, 3-phase, 7+2 core cable, winding for 1 voltage, delta connection

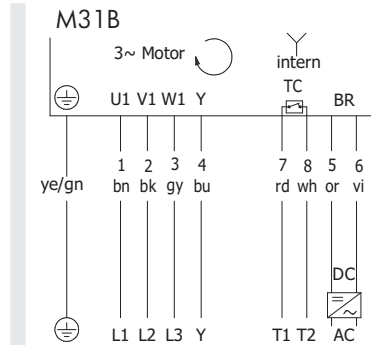

Fig.: With brake, 3-phase, 7+2 core cable, winding for 1 voltage, star connection

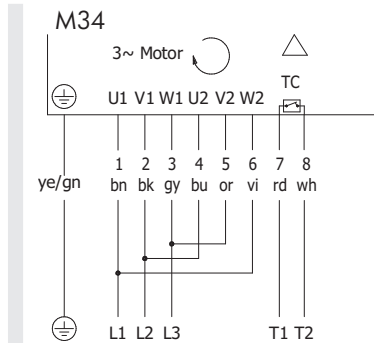

Fig.: 3-phase, 7+2 core cable, winding for 2 voltages, delta connection

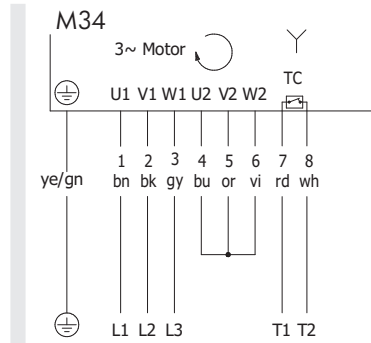

Fig.: 3-phase, 7+2-core cable, winding for 2 voltages, star connection

# DM SERIES CABLE OVERVIEW AND CONNECTION DIAGRAMS CONNECTION DIAGRAMS

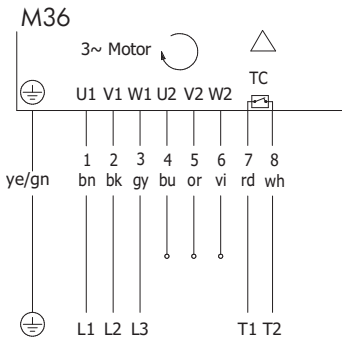

Fig.: 3-phase, 7+2 core cable, 2 speeds, delta connection

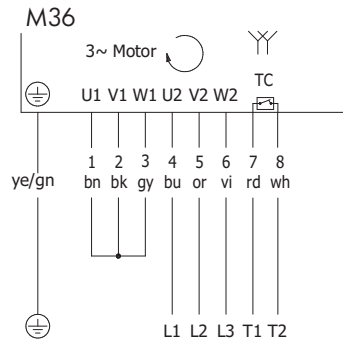

Fig.: 3-phase, 7+2 core cable, 2 speeds, double-star connection

## Terminal box 3-phase asynchronous motor

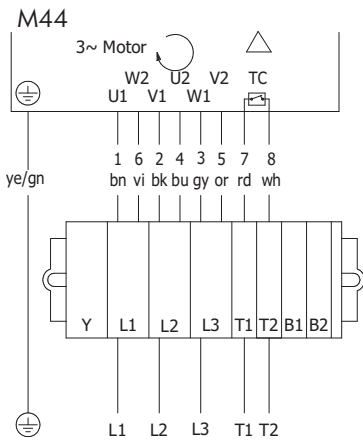

Fig.: 3-phase, winding for 2 voltages, delta connection

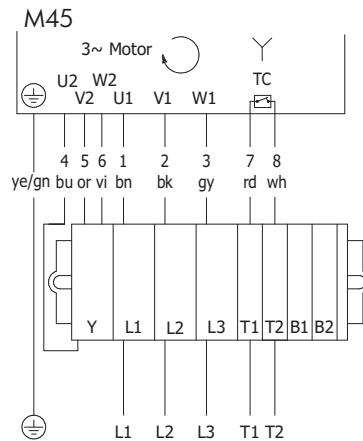

Fig.: 3-phase, winding for 2 voltages, star connection

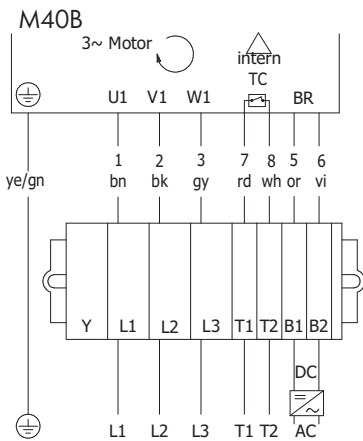

Fig.: With brake, 3-phase, winding for 1 voltage, delta connection

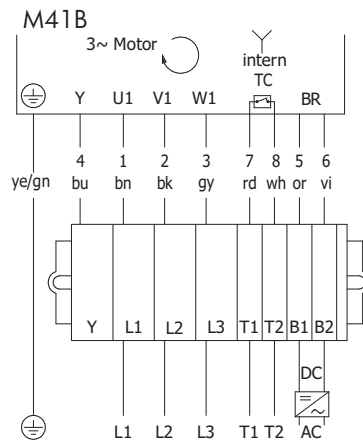
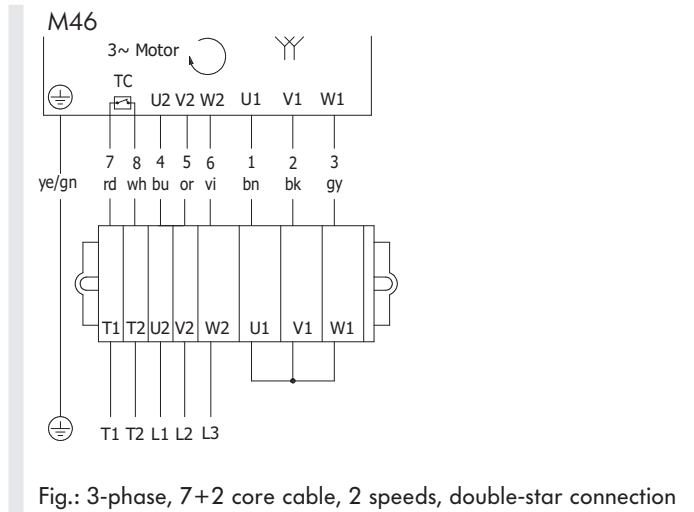
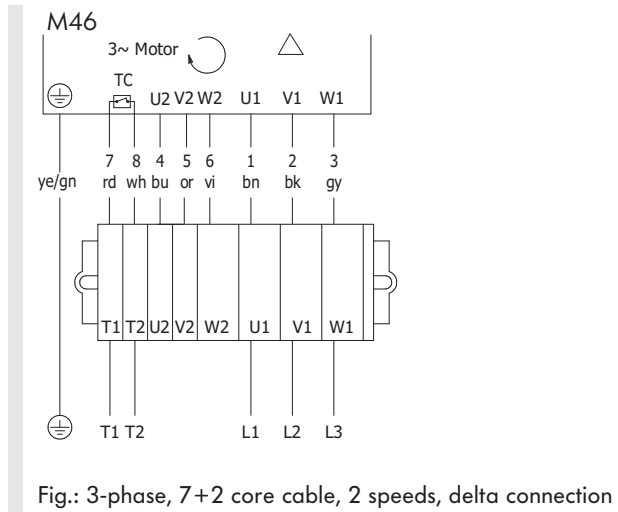

Fig.: With brake, 3-phase, winding for 1 voltage, star connection

# DM SERIES

## CABLE OVERVIEW AND CONNECTION DIAGRAMS

### CONNECTION DIAGRAMS



#### Cable connections 1-phase asynchronous motor

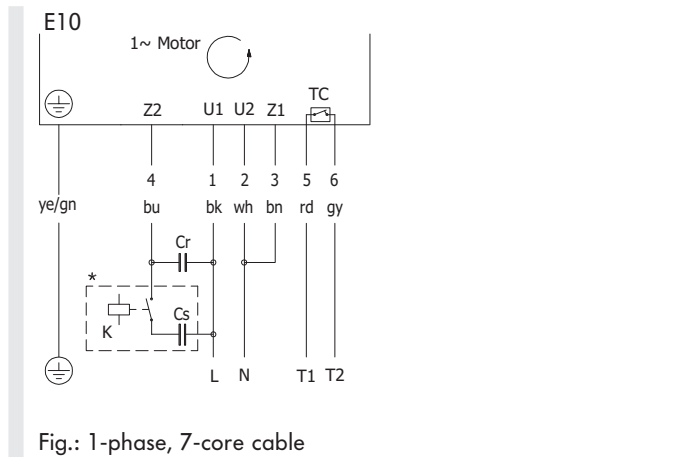
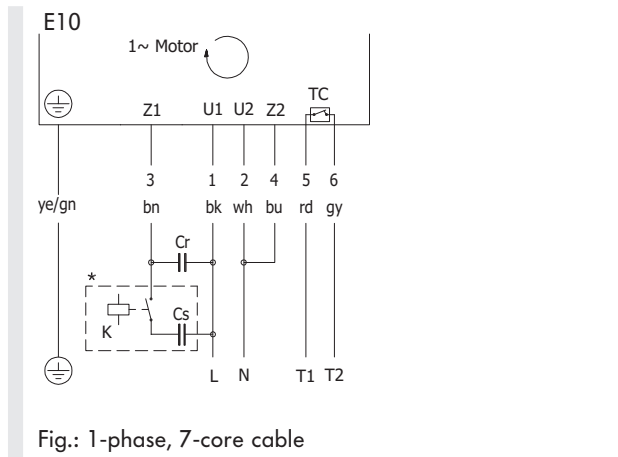

# DM SERIES

## CABLE OVERVIEW AND CONNECTION DIAGRAMS

### CONNECTION DIAGRAMS

#### Terminal box 1-phase asynchronous motor

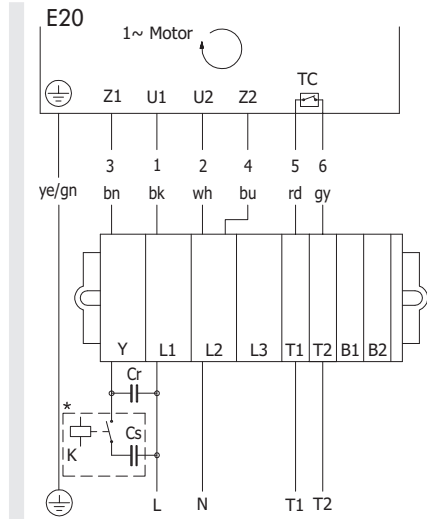

Fig.: 1-phase, 7-core cable

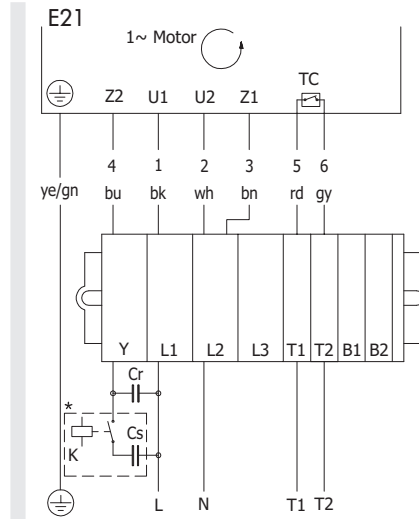

Fig.: 1-phase, 7-core cable

For more information about the starting relay, see page 190

# DM SERIES OPTIONS AND ACCESSORIES SPROCKETS

For drum motors and idler pulleys

## Sprockets



### Hygienic, quiet and long lifespan

The solid homogeneous polymer sprockets are suitable for applications in food processing with high hygienic requirements: Easy to clean and extremely resistant to oil, grease and chemicals. Furthermore, they ensure smooth running and provide a long lifespan of the belt due to its low abrasion. These sprockets are available for the most common positive drive solid homogeneous belts as well as for motors in applications with drive belts. Based on the specifications of the specific belt manufacturer, up to 44 teeth mesh with the profile.

**Note:** It is important to incorporate a calculation of belt pull and speed that is adjusted to the greater outer diameter of the drum motor. Please refer to the velocity factor (VF) in the table on page 135. Only one fixed sprocket per drum motor should be fitted to allow for belt expansion.

### Technical data

<b>Material</b>	Polyketon (PK) with stainless steel inlay
-----------------	---

# DM SERIES OPTIONS AND ACCESSORIES SPROCKETS

For drum motors and idler pulleys

## Versions

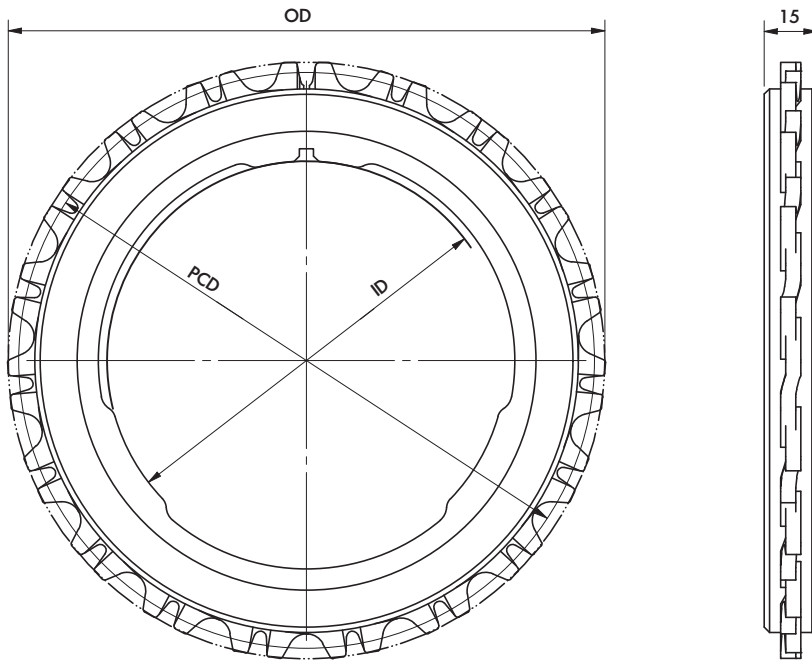

OD = Outer diameter in mm      PCD = Pitch diameter in mm  
ID = Inner diameter in mm

## Product selection

Drum motor	Belt manufacturer	Series	Article number	Belt drive	Z	ID [mm]	OD [mm]	PCD [mm]	VF
DM 0080	Intralox	2400	64100985	Floating	16	81.7	131.4	130	1.59
		2400	64101024	Fixed	16	81.7	131.4	130	1.59
		900	64100986	Floating	15	81.7	134.7	130.7	1.60
		900	64101025	Fixed	15	81.7	134.7	130.7	1.60
	Habasit	M25	64100987	Floating	16	81.7	131.9	130.8	1.60
		M25	64101026	Fixed	16	81.7	131.9	130.8	1.60
	Intralox	1000	64100988	Floating	24	81.7	121.7	115	1.41
		1000	64101027	Fixed	24	81.7	121.7	115	1.41
	Ammeraal Beltech/Uni- Chains	M-QNB	64100989	Floating	30	81.7	124.8	119.6	1.46
		M-QNB	64101028	Fixed	30	81.7	124.8	119.6	1.46
SNB-M2		64100990	Floating	16	81.7	134.4	129	1.58	
SNB-M2		64101029	Fixed	16	81.7	134.4	129	1.58	

# DM SERIES OPTIONS AND ACCESSORIES SPROCKETS

For drum motors and idler pulleys

Drum motor	Belt manufacturer	Series	Article number	Belt drive	Z	ID [mm]	OD [mm]	PCD [mm]	VF	
DM 0113	Intralox	2400	64100960	Floating	20	113	163.3	163.3	1.45	
		2400	64101030	Fixed	20	113	163.3	163.3	1.45	
		900	64100961	Floating	19	113	169	165	1.46	
		900	64101031	Fixed	19	113	169	165	1.46	
	Habasit	M25	64100975	Floating	20	113	165.2	163	1.44	
		M25	64101032	Fixed	20	113	165.2	163	1.44	
	Intralox	1000	64100976	Floating	32	113	161.1	154.3	1.37	
		1000	64101033	Fixed	32	113	161.1	154.3	1.37	
	Ammeraal Beltech/Uni-Chains	M-QNB	64100977	Floating	38	113	157.4	152.3	1.35	
		M-QNB	64101034	Fixed	38	113	157.4	152.3	1.35	
		SNB-M2	64100978	Floating	20	113	169.1	163.3	1.45	
		SNB-M2	64101035	Fixed	20	113	169.1	163.3	1.45	
	DM 0138	Intralox	2400	64100979	Floating	24	137	195.4	195.4	1.43
			2400	64101036	Fixed	24	137	195.4	195.4	1.43
900			64100980	Floating	22	137	195.6	191.6	1.40	
900			64101037	Fixed	22	137	195.6	191.6	1.40	
Habasit		M25	64100981	Floating	23	137	189.2	187.2	1.37	
		M25	64101038	Fixed	23	137	189.2	187.2	1.37	
Intralox		1000	64100982	Floating	40	137	188.3	181.7	1.33	
		1000	64101039	Fixed	40	137	188.3	181.7	1.33	
Ammeraal Beltech/Uni-Chains		M-QNB	64100983	Floating	44	137	182.4	177.1	1.29	
		M-QNB	64101040	Fixed	44	137	182.4	177.1	1.29	
		SNB-M2	64100984	Floating	23	137	192.7	187	1.36	
		SNB-M2	64101041	Fixed	23	137	192.7	187	1.36	

Z = Number of teeth  
 OD = Outer diameter in mm  
 PCD = Reference diameter in mm

VF = Velocity factor  
 ID = Inner diameter in mm



# DM SERIES OPTIONS AND ACCESSORIES BACKSTOPS AND BALANCING

For drum motors and idler pulleys

## Backstops and balancing

### Backstops

Backstops prevent a run-back of the belt and load when the power supply is off. Since such a stop is installed directly at the rotor shaft and operates mechanically, no electrical connection is required: The bearing runs only in one direction. This principle achieves a higher holding torque than an electromagnetic brake does.

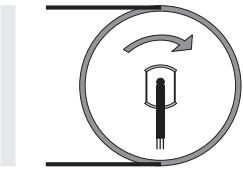

**Note:** Backstops are available only for asynchronous drum motors.

Rotational direction looking from the connector side: Available for clockwise (standard) or counterclockwise direction.

### Balancing

In principle, static or dynamic balancing can be applied - depending on requirement or motor type. The goal in each case is to reduce vibrations and out-of-balance running for sensitive high speed or dynamic weighing applications. Static balancing is applied to the drum motor shell only; therefore the result must be tested for each application. Dynamic balancing, on the other hand, includes the drum motor rotor, shell and end housings, thus meeting a balancing grade of G2.5.

Any external modification, such as fixtures, laggings or sprockets, has an impact on the imbalance.

### Technical data for dynamic balancing

<b>End housing</b>	Stainless steel
<b>Rubber lagging material</b>	Only hot vulcanized NBR and PU may be used
<b>Max. balancing length</b>	FW ≤ 800 mm

# DM SERIES OPTIONS AND ACCESSORIES ELECTROMAGNETIC BRAKES

For drum motors and idler pulleys

## Electromagnetic brakes

To safely hold loads on reversible inclined and declined conveyors, electromagnetic brakes are used. They operate via rectifiers. The braking force is applied directly to the rotor shaft of the drum motor. When power to the motor is disrupted, the brake will close automatically. Special advantage: Electromagnetic brakes are quiet and operate with low wear.

### Technical data

	DM 0080		DM 0113			DM 0138			DM 0165				DM 0217			
<b>Rated torque M [Nm]</b>	0.7	0.7	1.5	1.5	1.5	2.9	2.9	2.9	5.95	5.95	5.95	5.95*	12	5.95*	12	5.95*
<b>Rated power [W]</b>	8	10	16	17	16	25	22	22	33	33	33	33	50	33	50	33
<b>Rated voltage [V DC]</b>	24	104	24	104	207	24	104	207	24	104	207	24	104	104	207	207
<b>Rated current [A]</b>	0.33	0.096	0.66	0.163	0.077	1.0	0.211	0.11	1.38	0.32	0.16	1.38	0.48	0.32	0.24	0.16
<b>DC switching t1 [ms]</b>	13	13	26	26	26	26	26	26	46	46	46	46	46	60	46	60
<b>AC switching t1 [ms]</b>	80	80	200	200	200	200	200	200	260	260	260	260	260	500	260	500
<b>Opening delay time t2 [ms]</b>	20	20	30	30	30	30	30	30	40	40	40	40	40	40	40	60

\*Brake for DM 0217 for min. SL = 400 mm

### Response time

The brake opening and closing response time can vary substantially depending on the following:

- Oil type and viscosity
- Oil quantity in the drum motor
- Ambient temperature
- Internal operating temperature of the motor
- Switching at input (AC switching) or at output (DC switching)

The difference between AC switching and DC switching is shown in the following table:

	AC switching	DC switching
<b>Closing response time</b>	Slow	Fast
<b>Brake voltage</b>	Approx. 1 V	Approx. 500 V

**Note:** For DC switching, the switching contacts must be protected against damage from high voltage.

# DM SERIES OPTIONS AND ACCESSORIES ELECTROMAGNETIC BRAKES

For drum motors and idler pulleys

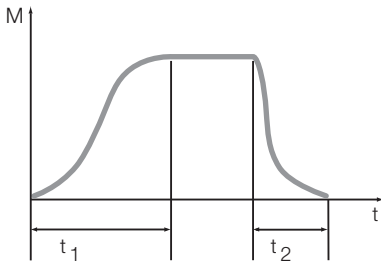

Fig.: Closing and opening response time

- $t_1$  = Closing response time
- $t_2$  = Opening response time

### Reduction of braking torque

The rated braking torque is heavily influenced by the operating conditions inside the drum motor (operation in oil at high temperatures) and the ambient temperature. To calculate the holding torque limit on the drum shell, you need to multiply the rated torque of the brake by the gear ratio of the drum motor. For safety reasons, the calculated brake torque has to be at least 25 % higher than the needed load torque.

# DM SERIES OPTIONS AND ACCESSORIES RECTIFIERS

For drum motors and idler pulleys

## Rectifiers

Electromagnetic brakes on drum motors are operated via rectifiers. Different versions are available depending on the applications: Half-wave and bridge rectifiers for standard applications as well as fast acting and multiswitch rectifiers for applications in which short opening delay times are necessary.

Every rectifier is an external component that must be covered or installed in a control box as close to the drum motor as possible.

## Technical data

Input voltage [V AC]	Brake voltage [V DC]	Starting voltage [V DC]	Holding voltage [V DC]	Version	Application	Article number
115	104	104	52	Fast acting rectifier	A or B	61 011 343
230	207	207	104	Fast acting rectifier	A or B	61 011 343
230	104	104	104	Half-wave rectifier	A	1 001 440
230	104	190	52	Phase rectifier	A or B	1 001 442
230	207	207	104	Fast acting rectifier	A or B	1 001 443
400	104	180	104	Multiswitch rectifier	A or B	1 003 326
460	104	180	104	Multiswitch rectifier	A or B	1 003 326
460	207	207	207	Half-wave rectifier	A	1 001 441
460	207	414	207	Fast acting rectifier	A or B	1 001 443

A = Continuous operation

B = Frequent starts/stops

Using a fast acting rectifier or a phase rectifier will save energy because the holding voltage is lower than the starting voltage.

Shielded cables should be used to protect against EMC.

# DM SERIES OPTIONS AND ACCESSORIES RECTIFIERS

For drum motors and idler pulleys

## Dimensions

### Half-wave rectifier

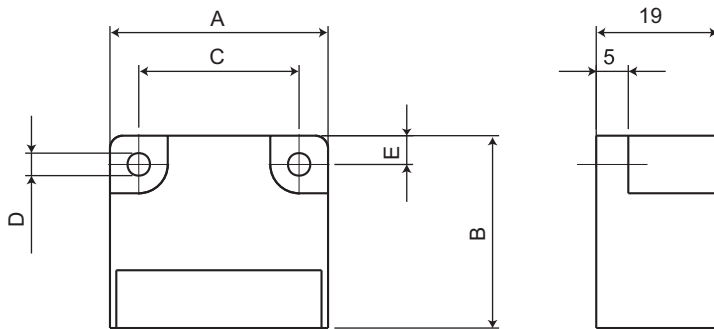

Article number	A [mm]	B [mm]	C [mm]	D [mm]	S [mm]
1001440	34	30	25	3.5	4.5
1001441	64	30	54	4.5	5

### Phase rectifier

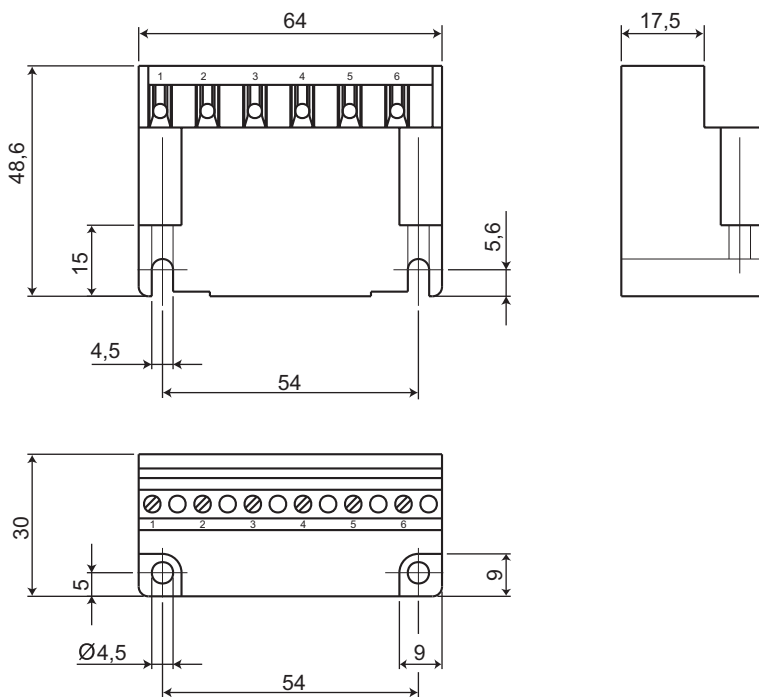

# DM SERIES OPTIONS AND ACCESSORIES RECTIFIERS

For drum motors and idler pulleys

## Fast-acting rectifier

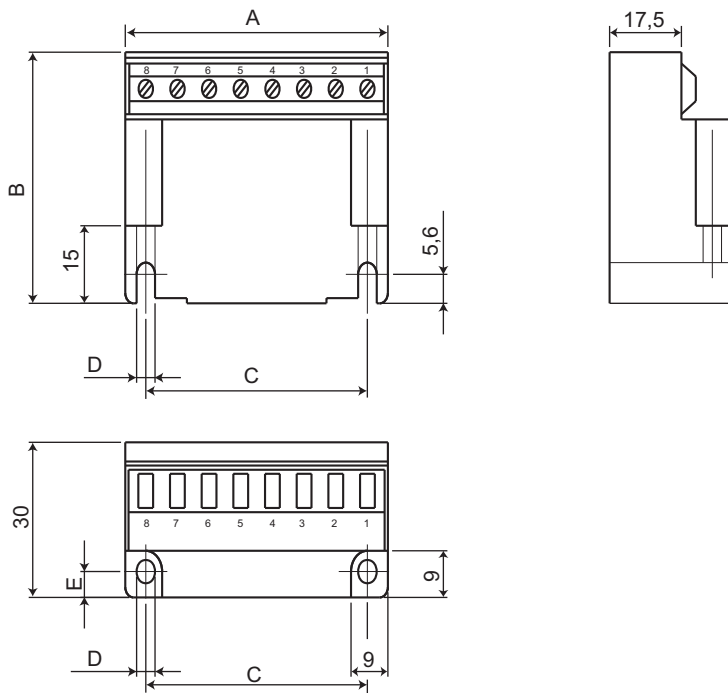

Article number	A [mm]	B [mm]	C [mm]	D [mm]	S [mm]
1001443	64	73.6	54	4.5	5
61011343	64	48.6	54	4.5	5

# DM SERIES OPTIONS AND ACCESSORIES RECTIFIERS

For drum motors and idler pulleys

## Multiswitch rectifier

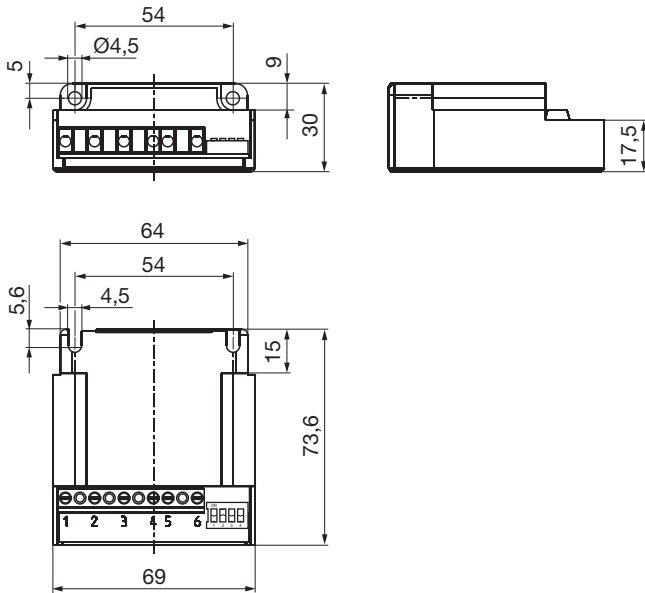

# DM SERIES OPTIONS AND ACCESSORIES RECTIFIERS

For drum motors and idler pulleys

## Connection diagram

Interroll recommends installing a switch between (3) and (4) for fast brake release.

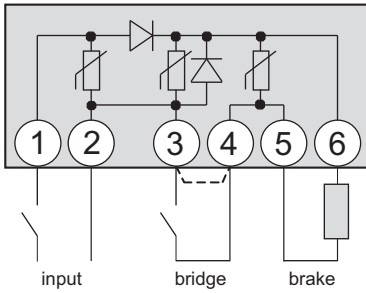

Fig.: Half-wave rectifier

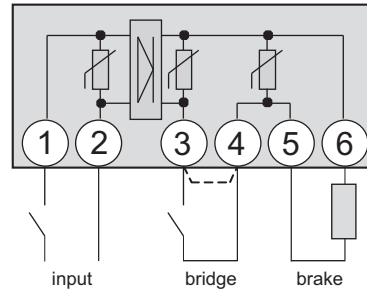

Fig.: Bridge rectifier

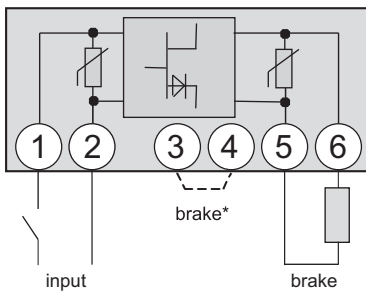

Fig.: Phase rectifier

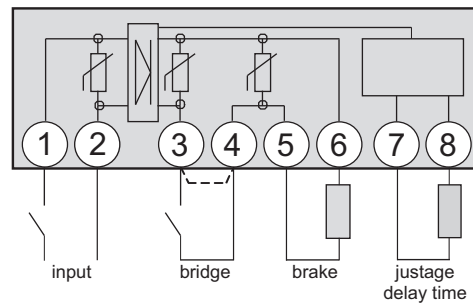

Fig.: Fast-acting rectifier

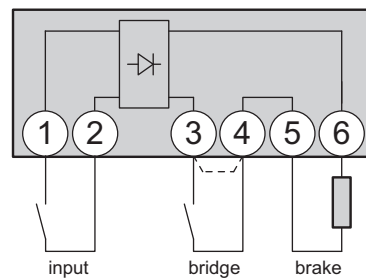

Fig.: Multiswitch rectifier



# DM SERIES OPTIONS AND ACCESSORIES ENCODER

For drum motors and idler pulleys

## Encoder

If speed, direction and position of the belt or load are to be permanently monitored and controlled, the use of an encoder is recommended. It enables a system control with closed control loop by transmitting low- to high-resolution signals to an external control unit. An encoder is installed onto the rotor shaft and cannot be used simultaneously with a brake or a backstop. Incremental encoders, absolute value encoders or resolvers are available as encoder types.

All resolutions and speeds provided in the following table refer to the rotor shaft. The drum motor gear ratio must be considered to find the values related to the drum shell.

Encoder types		Asynchronous drum motors	Synchronous drum motors
SKF 32 incremental encoder	32 pulses	●	
RLS incremental encoder	64 to 2048 pulses	●	●
LTN resolver	2-pole resolver	●	●

## Technical data

### SKF 32 incremental encoder

Power supply	$V_{dd} = 5 - 24 \text{ V}$
Current consumption	Max. 20 mA
Electrical interface	Open collector NPN
Output increments	A, B
Increments resolution	32 pulses/revolution
Max. cable length	10 m

**Note:** Interroll recommends the use of an optocoupler for the following reasons:

- To protect the encoder
- To enable connection to other levels such as PNP
- To get the maximum potential between high and low signal

### RLS incremental encoder

	RS422A 5 V	Push-pull 24 V
Supply voltage	$5 \text{ V} \pm 5 \%$	8–26 V
Power supply	35 mA	50 mA at 24 V
Increments resolution	32, 64, 128, 256, 512, 1024, 2048	32, 64, 128, 256, 512, 1024, 2048
Output signal	A, /A, B, /B, Z, /Z	A, /A, B, /B, Z, /Z
Max. cable length	5 m	5 m

# DM SERIES OPTIONS AND ACCESSORIES ENCODER

For drum motors and idler pulleys

## LTN resolver

Power supply	7 V
Input frequency range	5 kHz / 10 kHz
Input current	58 mA / 36 mA
Number of poles	2
Transformation ratio	0.5 ± 10 %
Max. cable length	10 m

## SKS36 Hiperface\* (Sick/Stegman)

Power supply	7 to 12 V (recommended 8 V)
Current consumption	max. 60 mA
Data transfer	Hiperface
Serial data	RS485
Single turn resolution	4096 positions / revolution
Sine/cosine periods per revolution	128
Max. cable length	10 m

\* More information about the SKS36 Hiperface (Sick/Stegman) is available from your Interroll customer representative.

## Connection diagrams

### Abbreviations

ye/gn = yellow/green  
wh = white  
bn = brown  
gn = green  
ye = yellow  
() = other color  
gy = gray

pk = pink  
rd = red  
bu = blue  
TC = Thermal controller (bi-metal switch)  
BR = Electromagnetic brakes  
NC = Not connected

# DM SERIES OPTIONS AND ACCESSORIES ENCODER

For drum motors and idler pulleys

## SKF 32 incremental encoder

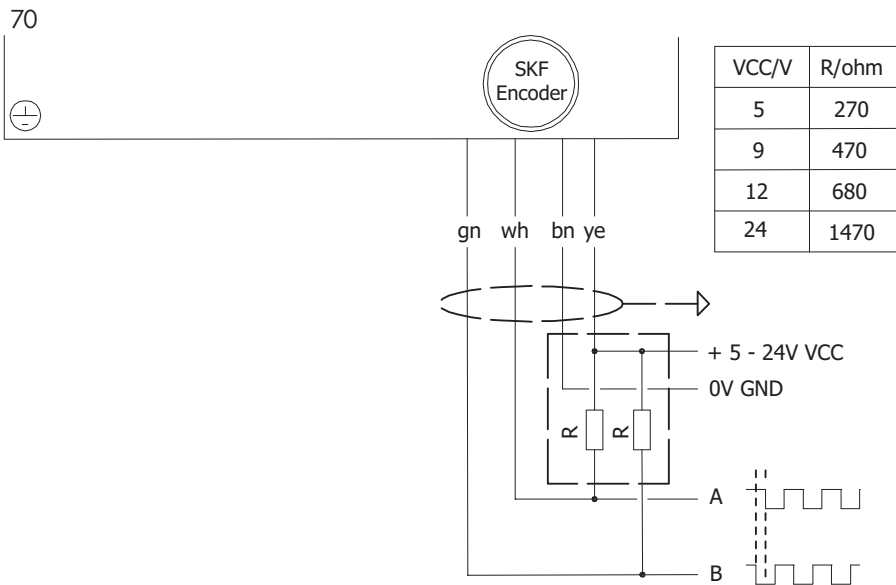

## RLS incremental encoder

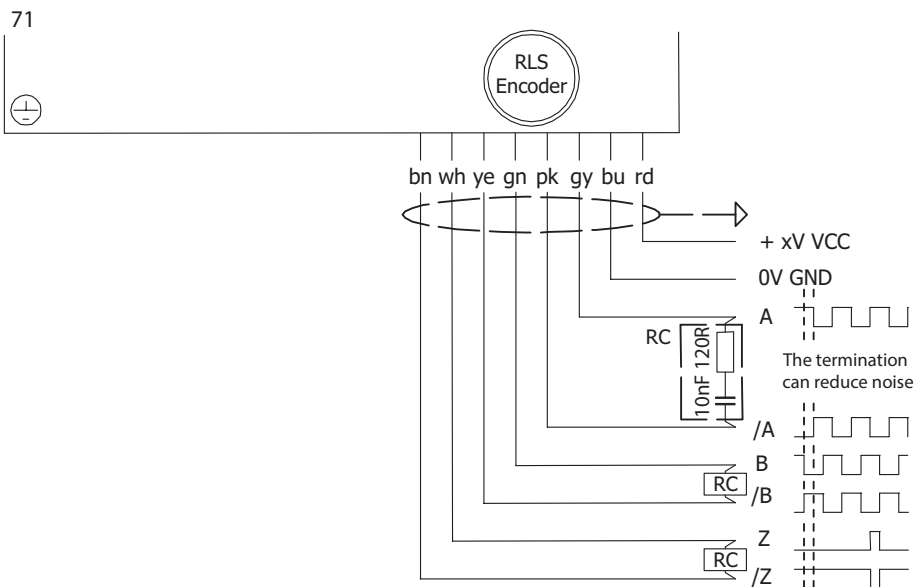

# DM SERIES OPTIONS AND ACCESSORIES ENCODER

For drum motors and idler pulleys

## LTN resolver

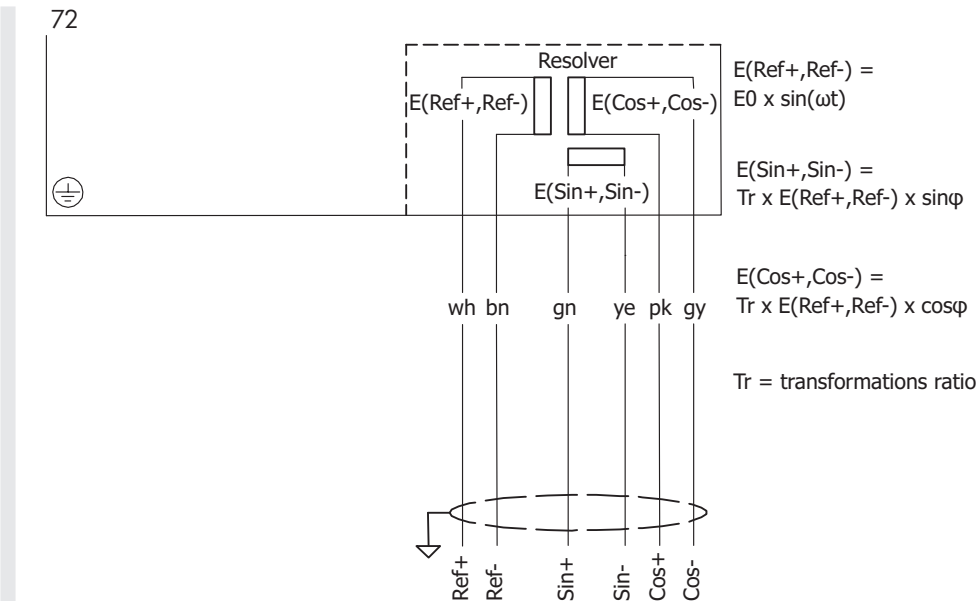

## SKS36 Hiperface\* (Sick/Stegman)

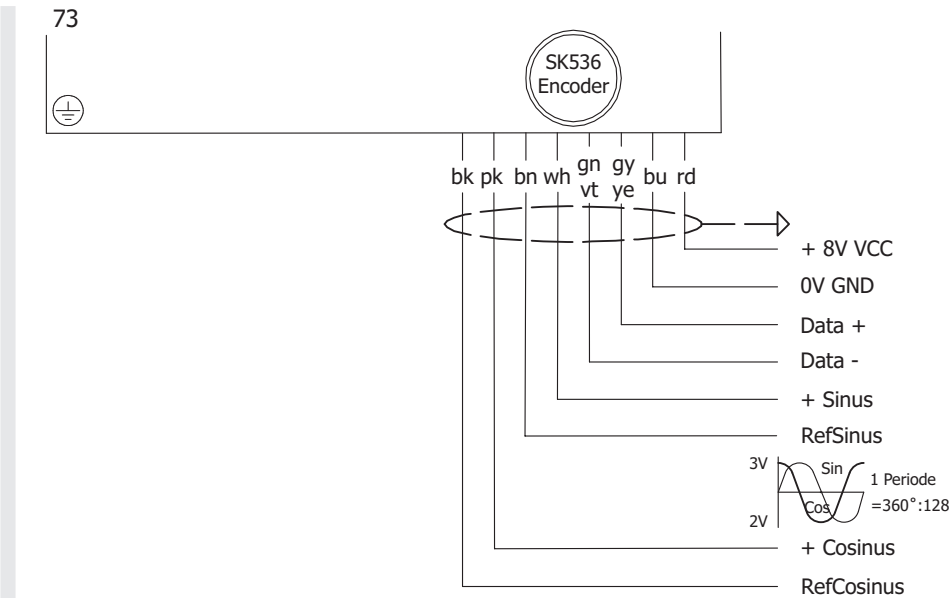

\* More information about the SKS36 Hiperface (Sick/Stegman) is available from your Interroll customer representative.

# DM SERIES OPTIONS AND ACCESSORIES MOUNTING BRACKETS

For drum motors and idler pulleys

## Cable

	Cable for incremental encoder SKF 32	Cable for incremental encoder RLS	Cable for resolver LTN	SKS36 Hiperface (Sick/ Stegman)
<b>Main cores (number)</b>	4	8	6	8
<b>Cross section</b>	0.14 mm <sup>2</sup>	0.14 mm <sup>2</sup>	0.14 mm <sup>2</sup>	0.15 mm <sup>2</sup>
<b>Numeric code and color code</b>	Color code	Color code	Color code	Color code
<b>Insulation conductors (main cores)</b>	PVC	PVC	PVC	PP
<b>Insulation conductors (data cores)</b>	PVC	PVC	PVC	PUR
<b>Halogen-free</b>	No	Yes	No	Yes
<b>Color of outer sheath</b>	Gray	Gray	Gray	Black
<b>Shielded</b>	Copper	Copper	Copper	Copper
<b>Outside diameter</b>	4.3 ± 0.3 mm	5.0 ± 0.2 mm	5.8 ± 0.3 mm	5.3 ± 0.3 mm
<b>Operating voltage max.</b>	250 V	524 V	350 V	250 V
<b>Temperature range</b>	-20 to +105 °C according to UL	-20 to +105 °C according to UL	-20 to +80 °C according to UL	-20 to +80 °C according to UL

## Mounting brackets

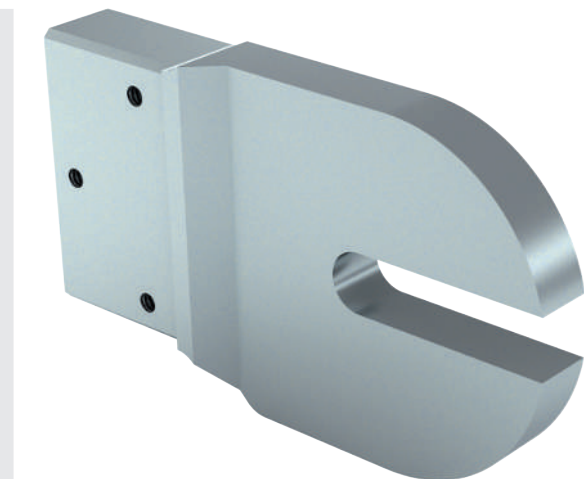

In order to securely fasten Interroll Drum Motors, the corresponding idler pulleys or motors with cable connectors or terminal boxes, suitable brackets made of stainless steel, aluminum and PE are available. It is important that the drum motors feature a continuous threaded hole in the front shaft and idler pulleys a corresponding drilled hole in both shaft ends.

For the dimensions of shafts with threaded holes, refer to the dimensional drawings for the corresponding drum motor.

# DM SERIES OPTIONS AND ACCESSORIES MOUNTING BRACKETS

For drum motors and idler pulleys

## Product selection

Drum motor	Idler pulley	Fastening set	Material	Electrical connector	Article number			
					WAF 13.5 mm	WAF 20 mm	WAF 25 mm	WAF 30 mm
DM 0080		A + B	Aluminum	Elbow connector Straight connector Terminal box	61008694	61113879	61113880	
	IM 0080	B + C	Aluminum		61008696	61113885	61113886	
DM 0080		A + B	PE	Elbow connector Straight connector Terminal box	61008693	61113889	61113890	
	IM 0080	B + C	PE		61008695	61113895	61113896	
DM 0080		A + B	Stainless steel	Elbow connector Straight connector Terminal box	61113943	61113944	61113945	
	IM 0080	B + C	Stainless steel		61113946	61113947	61113948	
DM 0113		A + B	Aluminum	Elbow connector Straight connector Terminal box		61008698	61115658	
DM 0113		A + B	Aluminum	Cable connection slot		61008699	61115661	
	IM 0113	B + C	Aluminum			61008701	61115664	
DM 0113		A + B	PE	Elbow connector Straight connector Terminal box		61006805	61115659	
DM 0113		A + B	PE	Cable connection slot		61008697	61115662	
	IM 0113	B + C	PE			61008700	61115665	
DM 0113		A + B	Stainless steel	Elbow connector Straight connector Terminal box		61115655	61115657	
DM 0113		A + B	Stainless steel	Cable connection slot		61115656	61115660	
	IM 0113	B + C	Stainless steel			61115654	61115663	

# DM SERIES OPTIONS AND ACCESSORIES MOUNTING BRACKETS

For drum motors and idler pulleys

Drum motor	Idler pulley	Fastening set	Material	Electrical connector	Article number			
					WAF 13.5 mm	WAF 20 mm	WAF 25 mm	WAF 30 mm
DM 0138		A + B	Aluminum	Elbow connector Straight connector Terminal box		61008704	61116284	
DM 0138		A + B	Aluminum	Cable connection slot		61103900	61116285	
	IM 0138	B + C	Aluminum			61008706	61116286	
DM 0138		A + B	PE	Elbow connector Straight connector Terminal box		61008702	61116287	
DM 0138		A + B	PE	Cable connection slot		61100570	61116288	
	IM 0138	B + C	PE			61008705	61116289	
DM 0138		A + B	Stainless steel	Elbow connector Straight connector Terminal box		61116298	61116295	
DM 0138		A + B	Stainless steel	Cable connection slot		61116299	61116296	
	IM 0138	B + C	Stainless steel			61116300	61116297	
DM 0165*		A + B	Aluminum	Elbow connector Straight connector Terminal box				61008707
DM 0165*		A + B	Aluminum	Cable connection slot				61103901
	IM 0165*	B + C	Aluminum					61008708

Please take the key flat length into account when ordering the drum motor.

\* DM 0165 only with key flat lengths of 25 mm

WAF = Width across flats

# DM SERIES OPTIONS AND ACCESSORIES MOUNTING BRACKETS

For drum motors and idler pulleys

## Mounting overview

Brackets must be mounted in the following way:

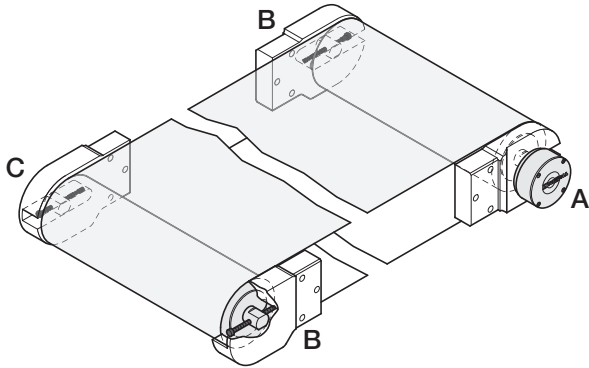

## Dimensions DM 0080

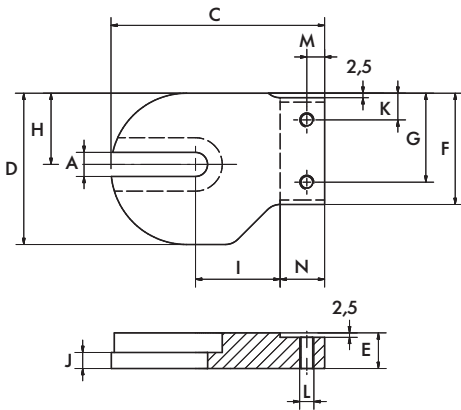

Fig.: Right bracket (A) aluminum or VA

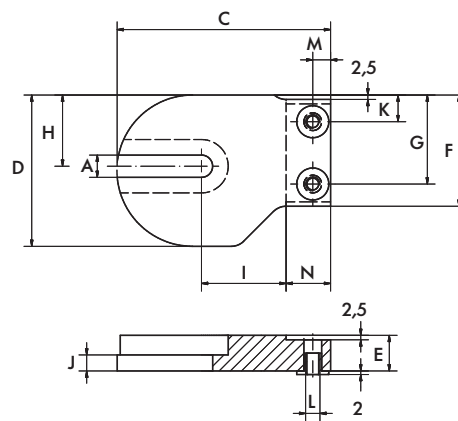

Fig.: Right bracket (A) PE

Drum motor/deflection roller	A [mm]	C [mm]	D [mm]	S [mm]	F [mm]	G [mm]	H [mm]	I [mm]	J [mm]	K [mm]	L	M [mm]	N [mm]
DM 0080	13.5	120	85	20	62.5	50	40	47.5	9	15	M8	10	25
	20	120	85	20	62.5	50	40	47.5	9	15	M8	10	25
	25	120	85	20	62.5	50	40	47.5	9	15	M8	10	25



# DM SERIES OPTIONS AND ACCESSORIES MOUNTING BRACKETS

For drum motors and idler pulleys

DL series

DM series

DP series

Application notes

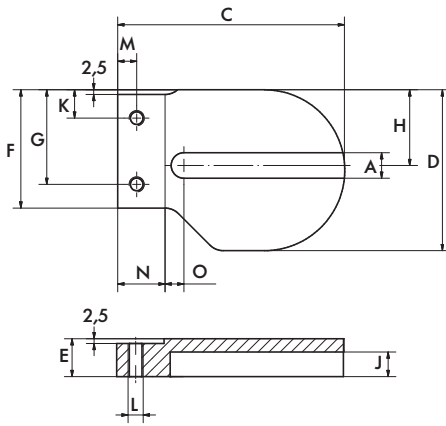

Fig.: Left bracket (B) aluminum or VA

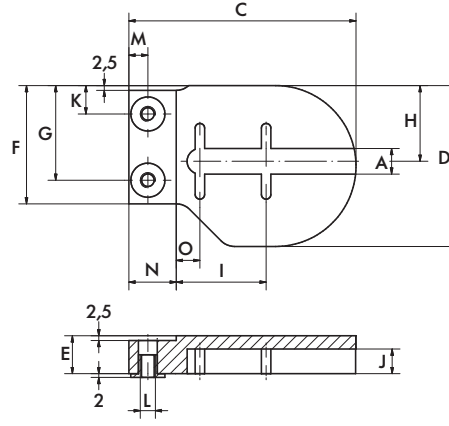

Fig.: Left bracket (B) PE

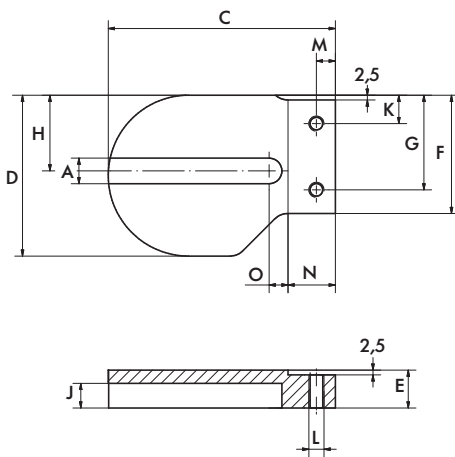

Fig.: Right bracket (C) aluminum or VA

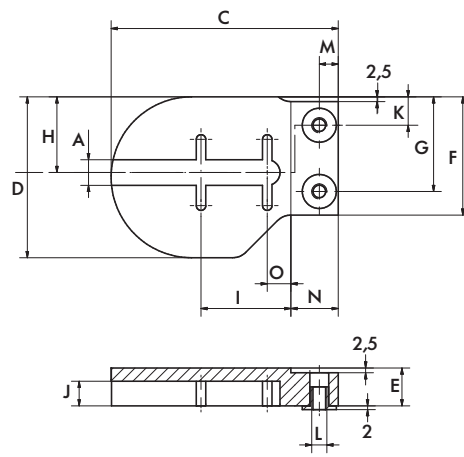

Fig.: Right bracket (C) PE

Drum motor/ idler pulley	Material	A [mm]	C [mm]	D [mm]	S [mm]	F [mm]	G [mm]	H [mm]	I [mm]	J [mm]	K [mm]	L	M [mm]	N [mm]	O [mm]
DM 0080	Aluminum	13.5	120	85	20	62.5	50	40	–	13	15	M8	10	25	10
		20	120	85	20	62.5	50	40	–	13	15	M8	10	25	10
		25	120	85	20	62.5	50	40	–	13	15	M8	10	25	10
	PE	13.5	120	85	20	62.5	50	40	42.5	13	15	M8	10	25	12.5
		20	120	85	20	62.5	50	40	42.5	13	15	M8	10	25	12.5
		25	120	85	20	62.5	50	40	42.5	13	15	M8	10	25	12.5
	VA	13.5	120	85	20	62.5	50	40	–	13	15	M8	10	25	10
		20	120	85	20	62.5	50	40	–	13	15	M8	10	25	10
		25	120	85	20	62.5	50	40	–	13	15	M8	10	25	10

# DM SERIES OPTIONS AND ACCESSORIES MOUNTING BRACKETS

For drum motors and idler pulleys

## DM 0113, DM 0138 and DM 0165 dimensions

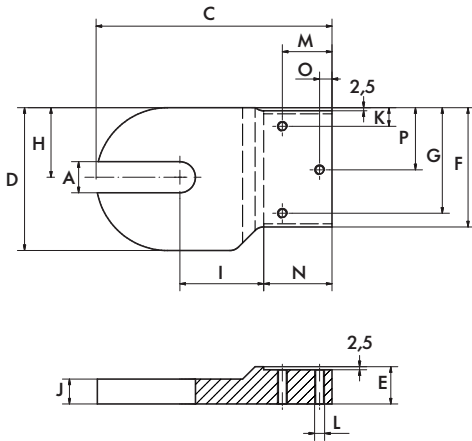

Fig.: Right bracket (A) aluminum or VA

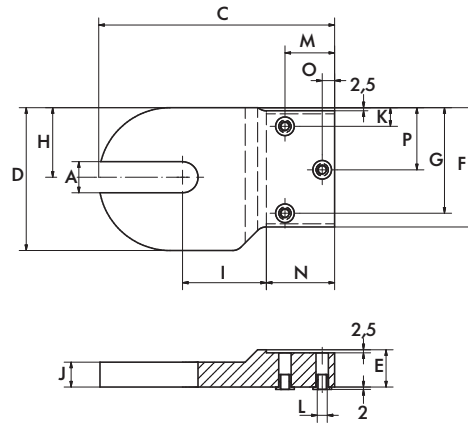

Fig.: Right bracket (A) PE

Drum motor/ deflection roller	A [mm]	C [mm]	D [mm]	S [mm]	F [mm]	G [mm]	H [mm]	I [mm]	J [mm]	K [mm]	L	M [mm]	N [mm]	O [mm]	P [mm]
DM 0113	20	190	115	30	96	85	56	67.5	20	15	M8	40	55	10	50
	25	190	115	30	96	85	56	67.5	20	15	M8	40	55	10	50
DM 0138	20	200	140	30	121	110	67	65	20	15	M10	40	55	10	62.5
	25	200	140	30	121	110	67	65	20	15	M10	40	55	10	62.5
DM 0165	30	240	170	30	146	122.5	81	100	20	27.5	M10	40	55	10	75

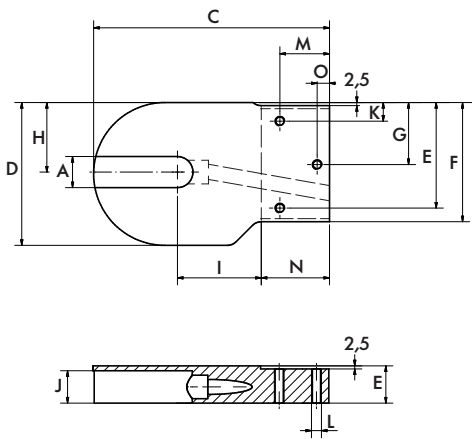

Fig.: Right bracket (A) aluminum or VA with cable connection slot

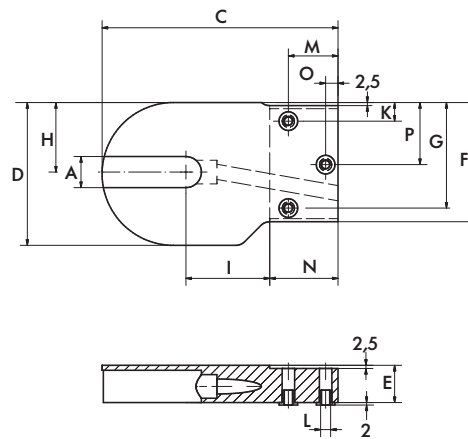

Fig.: Right bracket (A) PE for drum motor with cable connection slot

# DM SERIES OPTIONS AND ACCESSORIES MOUNTING BRACKETS

For drum motors and idler pulleys

Drum motor/ deflection roller	A [mm]	C [mm]	D [mm]	S [mm]	F [mm]	G [mm]	H [mm]	I [mm]	J [mm]	K [mm]	L	M [mm]	N [mm]	O [mm]	P [mm]
DM 0113	20	190	115	30	96	85	56	67.5	26	15	M8	40	55	10	50
	25	190	115	30	96	85	56	67.5	26	15	M8	40	55	10	50
DM 0138	20	200	140	30	121	110	67	65	20	15	M10	40	55	10	62.5
	25	200	140	30	121	110	67	65	20	15	M10	40	55	10	62.5
DM 0165	30	240	170	30	146	122.5	81	100	20	27.5	M10	40	55	10	75

DL series

DM series

DP series

Application notes

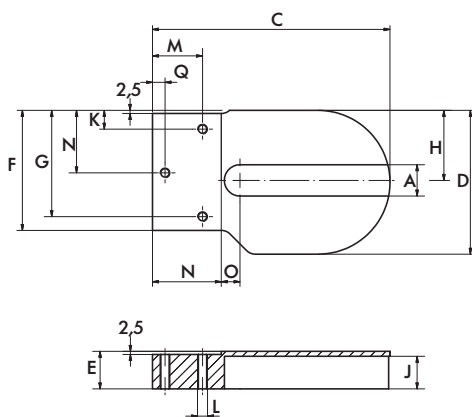

Fig.: Left bracket (B) aluminum or PE

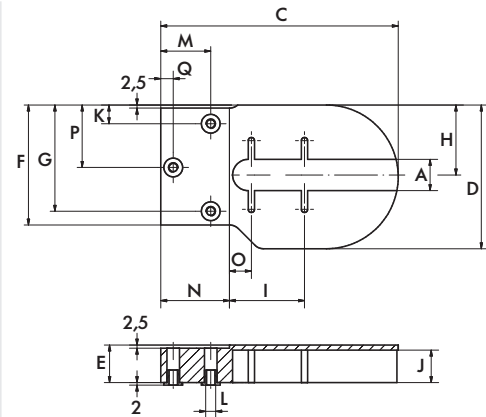

Fig.: Left bracket (B) PE

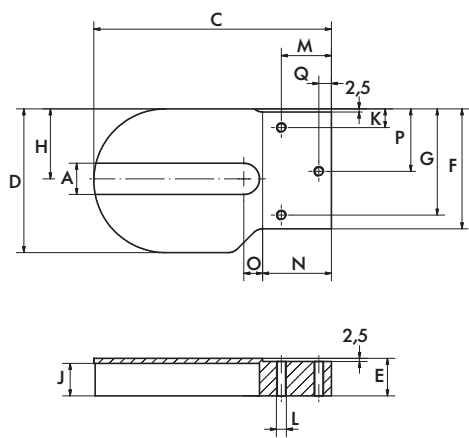

Fig.: Right bracket (C) aluminum or PE

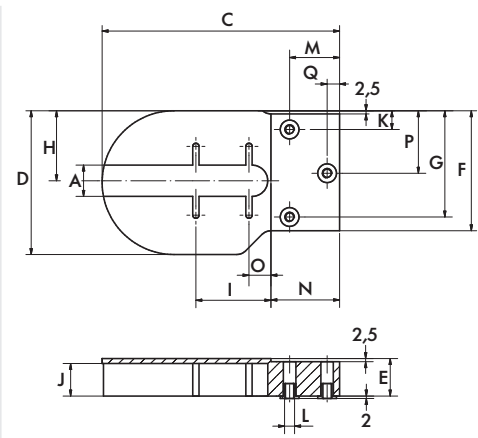

Fig.: Right bracket (C) PE

# DM SERIES OPTIONS AND ACCESSORIES MOUNTING BRACKETS

For drum motors and idler pulleys

Drum motor/ idler pulley	Material	A [mm]	C [mm]	D [mm]	S [mm]	F [mm]	G [mm]	H [mm]	I [mm]	J [mm]	K [mm]	L	M [mm]	N [mm]	O [mm]	P [mm]	Q [mm]
DM 0113	Aluminum	20	190	115	30	96	85	56	–	26	15	M8	40	55	15	50	10
		25	190	115	30	96	85	56	–	26	15	M8	40	55	15	50	10
	PE	20	190	115	30	96	85	56	60	26	15	M8	40	55	17.5	50	10
		25	190	115	30	96	85	56	60	26	15	M8	40	55	17.5	50	10
	Stainless steel	20	190	115	30	96	85	56	–	26	15	M8	40	55	15	50	10
		25	190	115	30	96	85	56	–	26	15	M8	40	55	15	50	10
DM 0138	Aluminum	20	200	140	30	121	110	67	–	26	15	M10	40	55	15	62.5	10
		25	200	140	30	121	110	67	–	26	15	M10	40	55	15	62.5	10
	PE	20	200	140	30	121	110	67	62.5	26	15	M10	40	55	17.5	62.5	10
		25	200	140	30	121	110	67	62.5	26	15	M10	40	55	17.5	62.5	10
	Stainless steel	20	200	140	30	121	110	67	–	26	15	M10	40	55	15	62.5	10
		25	200	140	30	121	110	67	–	26	15	M10	40	55	15	62.5	10
DM 0165	Aluminum	30	240	170	30	146	122.5	81	–	26	27.5	M10	40	55	20	75	10

# DM SERIES OPTIONS AND ACCESSORIES PLUMMER BLOCK

For drum motors and idler pulleys

## Plummer block

The plummer block bracket supports a simple assembly of the drum motors and idler pulleys.

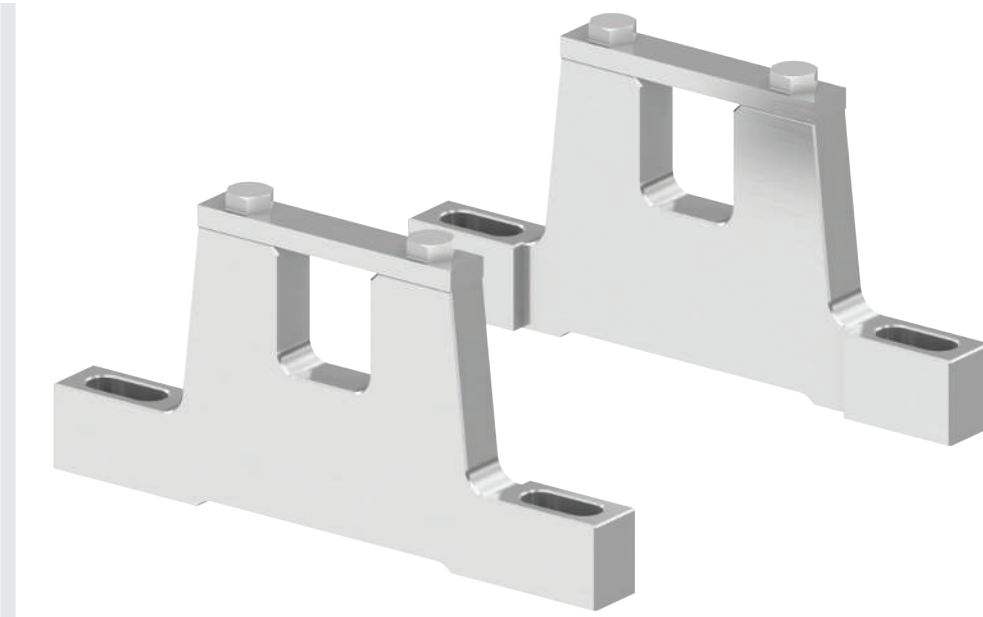

## Product selection

Drum motor	Material	Article number			
		WAF 13.5 mm	WAF 20 mm	WAF 25	WAF 30
DM 0080	Aluminum	61008580	61113900	61010381	
	Stainless steel	61113949	61113950	61113951	
DM 0113	Aluminum	–	61008581	61115653	
	Stainless steel	–	61115651	61115652	
DM 0138	Aluminum	–	61008582	61116301	
	Stainless steel	–	61116302	61116303	
DM 0165 / DM 0217	Cast iron	–	–	–	61009983
	Aluminum	–	–	–	61100431

WAF = Width across flats

# DM SERIES OPTIONS AND ACCESSORIES PLUMMER BLOCK

For drum motors and idler pulleys

## Dimensions

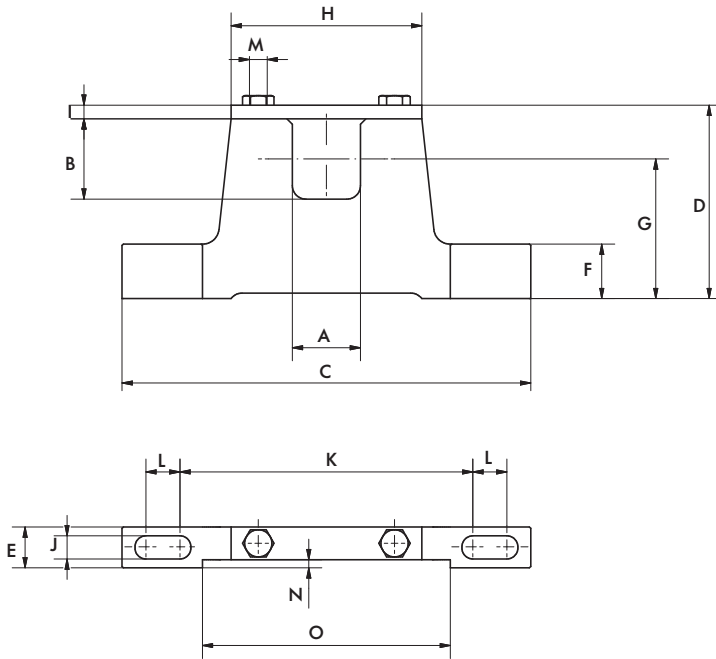

Drum motor/ idler pulley	Material	A [mm]	B [mm]	C [mm]	D [mm]	S [mm]	F [mm]	G [mm]	H [mm]	I [mm]	J [mm]	K [mm]	L [mm]	M [mm]	N [mm]	O [mm]
DM 0080		13.5	16.5	100	47.5	10	12	35	35	4	6.5	72.5	7.5	M6	-	-
		20	24.5	150	68.5	15	20	51	70	5	8.5	108	12	M6	3	91
		25	29.5	150	71	15	20	51	70	5	8.5	108	12	M6	3	91
DM 0113		20	24.5	150	59.5	20	15	42.5	55	5	8.5	118.5	6.5	M6	-	-
		25	29.5	150	59.5	20	15	40	55	5	8.5	118.5	6.5	M6	-	-
DM 0138		20	29.5	150	64.5	20	15	44.5	55	5	8.5	118.5	6.5	M6	-	-
		25	29.5	150	64.5	20	15	44.5	55	5	8.5	118.5	6.5	M6	-	-
DM 0165 / DM 0217	Aluminum	30	39.5	170	75	20	20	50	70	5	11	116	14	M8	-	-
	Cast iron	30	36	187	75	40	22	50	72	5	14	110	20	M10	-	-

# **DM SERIES OPTIONS AND ACCESSORIES PLUMMER BLOCK**

For drum motors and idler pulleys

---

DL series

**DM series**

DP series

Application notes

## **DM SERIES OPTIONS AND ACCESSORIES IDLER PULLEY WITH INTEGRATED BEARINGS**

---

Interroll deflection rollers can be used on the driven side of conveyor belts. The deflection roller with integrated bearings has a fixed shaft and the same dimensions as a drum motor.

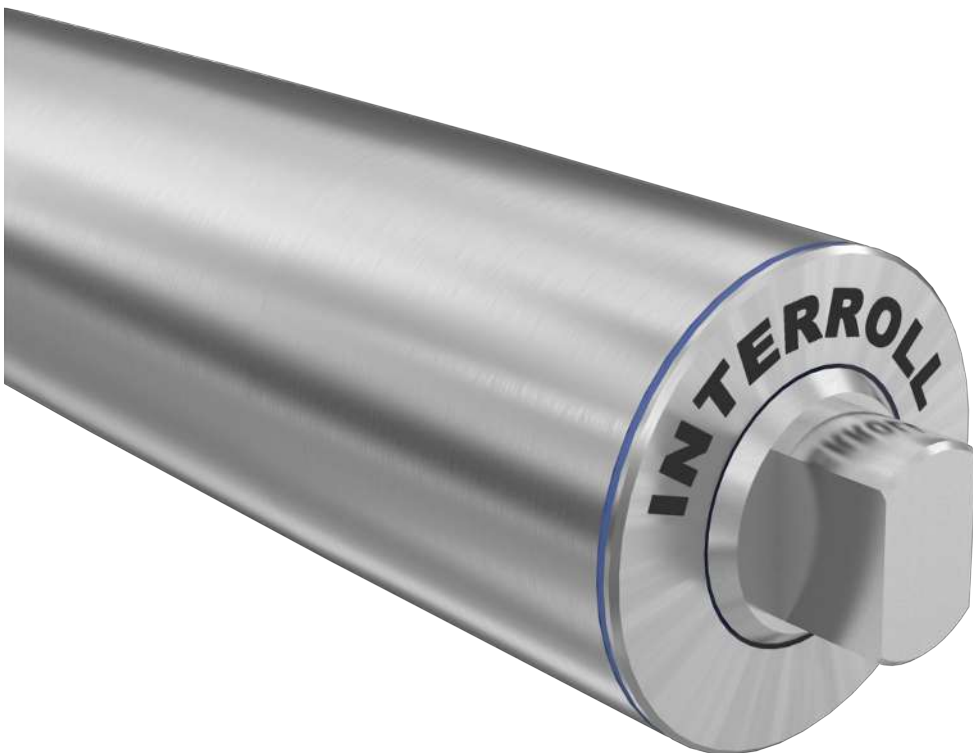



# DM SERIES

## OPTIONS AND ACCESSORIES

### IDLER PULLEY WITH INTEGRATED BEARINGS

#### Technical data

<b>Protection rate</b>	IP69k
<b>Max. belt tension</b>	See equivalent drum motor
<b>Max. belt speed</b>	See equivalent drum motor
<b>Shell length</b>	See equivalent drum motor
<b>Internal shaft sealing system</b>	NBR
<b>External shaft sealing system</b>	PTFE

#### Design versions

For idler pulleys you can choose the following design versions:

Component	Option	Material			
		Aluminum	Mild steel	Stainless steel	PTFE
Shell	Crowned		●	●	
	Cylindrical		●	●	
	Cylindrical + key for sprockets		●	●	
End housing		●		●	
Shaft				●	
External seal	PTFE				●

#### Versions

- Laggings for friction drive belts
- Laggings for modular plastic belts
- Laggings for positive drive solid homogenous belts

# DM SERIES

## OPTIONS AND ACCESSORIES

### IDLER PULLEY WITH INTEGRATED BEARINGS

#### Dimensions

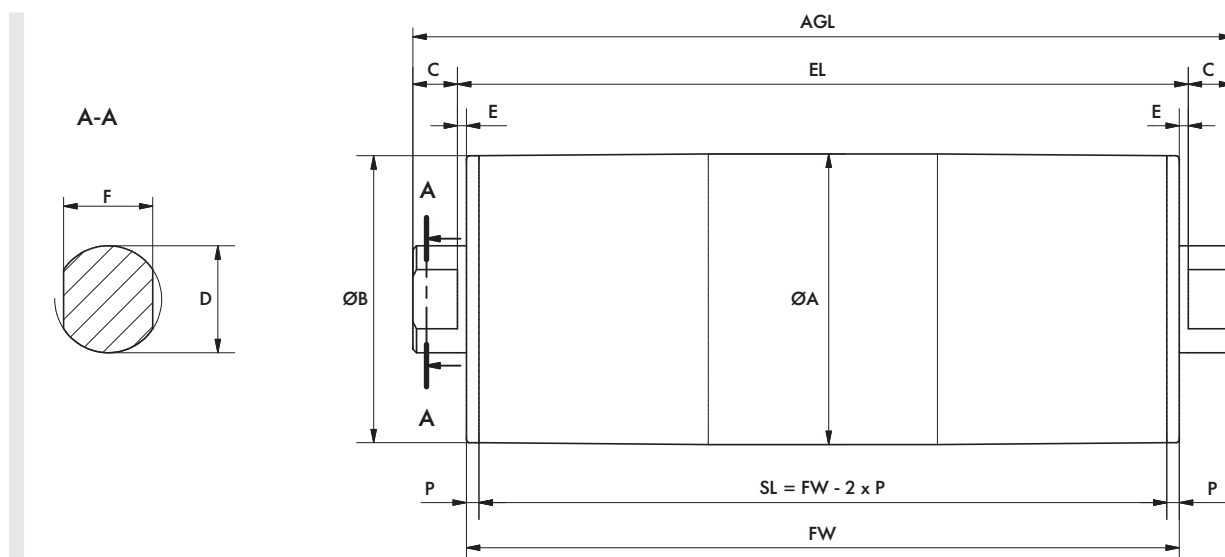

Type		A [mm]	B [mm]	C [mm]	D [mm]	S [mm]	F [mm]	P [mm]	SL [mm]	EL [mm]	AGL [mm]
IM 0080 crowned	Standard	81.5	80.5	12.5	30	2.5	25	3.5	FW - 7	FW + 5	FW + 30
	Optional	81.5	80.5	12.5	25	2.5	20	3.5	FW - 7	FW + 5	FW + 30
	Optional	81.5	80.5	12.5	17	2.5	13.5	3.5	FW - 7	FW + 5	FW + 30
IM 0080 cylindrical	Standard	81	81	12.5	30	2.5	25	3.5	FW - 7	FW + 5	FW + 30
	Optional	81	81	12.5	25	2.5	20	3.5	FW - 7	FW + 5	FW + 30
	Optional	81	81	12.5	17	2.5	13.5	3.5	FW - 7	FW + 5	FW + 30
IM 0113 crowned	Standard	113	112	25	30	6.5	25	3.5	FW - 7	FW + 13	FW + 63
	Optional	113	112	25	25	6.5	20	3.5	FW - 7	FW + 13	FW + 63
IM 0113 cylindrical	Standard	112	112	25	30	6.5	25	3.5	FW - 7	FW + 13	FW + 63
	Optional	112	112	25	25	6.5	20	3.5	FW - 7	FW + 13	FW + 63
IM 0113 cylindrical + key	Standard	113	113	25	30	6.5	25	3.5	FW - 7	FW + 13	FW + 63
	Optional	113	113	25	25	6.5	20	3.5	FW - 7	FW + 13	FW + 63

# DM SERIES

## OPTIONS AND ACCESSORIES

### IDLER PULLEY WITH INTEGRATED BEARINGS

Type		A [mm]	B [mm]	C [mm]	D [mm]	S [mm]	F [mm]	P [mm]	SL [mm]	EL [mm]	AGL [mm]
IM 0138 crowned	Standard	138	136	25	30	11.5	25	3.5	FW - 7	FW + 23	FW + 73
	Optional	138	136	25	30	11.5	20	3.5	FW - 7	FW + 23	FW + 73
IM 0138 cylindrical	Standard	136	136	25	30	11.5	25	3.5	FW - 7	FW + 23	FW + 73
	Optional	136	136	25	30	11.5	20	3.5	FW - 7	FW + 23	FW + 73
IM 0138 cylindrical + key	Standard	137	137	25	30	11.5	25	3.5	FW - 7	FW + 23	FW + 73
	Optional	137	137	25	30	11.5	20	3.5	FW - 7	FW + 23	FW + 73
IM 0165 crowned	Standard	164	162	25	30	16.5	25	3.5	FW - 7	FW + 33	FW + 83
	Optional	164	162	45	40	16.5	30	3.5	FW - 7	FW + 33	FW + 123
IM 0165 cylindrical	Standard	162	162	25	30	16.5	25	3.5	FW - 7	FW + 33	FW + 83
	Optional	162	162	45	40	16.5	30	3.5	FW - 7	FW + 33	FW + 123
IM 0165 cylindrical + key	Standard	162	162	25	30	16.5	25	3.5	FW - 7	FW + 33	FW + 83
	Optional	162	162	45	40	16.5	30	3.5	FW - 7	FW + 33	FW + 123
IM 0217 crowned	Standard	217.5	215.5	45	30	16.5	25	5	FW - 10	FW + 33	FW + 123
	Optional	217.5	215.5	45	40	16.5	30	5	FW - 10	FW + 33	FW + 123
IM 0217 cylindrical	Standard	215.5	215.5	45	30	16.5	25	5	FW - 10	FW + 33	FW + 123
	Optional	215.5	215.5	45	40	16.5	30	5	FW - 10	FW + 33	FW + 123
IM 0217 cylindrical + key	Standard	215.5	215.5	45	30	16.5	25	5	FW - 10	FW + 33	FW + 123
	Optional	215.5	215.5	45	40	16.5	30	5	FW - 10	FW + 33	FW + 123

DL series

DM series

DP series

Application notes

# DRUM MOTOR DP SERIES PALLET DRIVE 0080 / 0089



With the new space saving Interroll Pallet Drive, design and installation of the driven pallet conveyors is very easy. It is the perfect single-zone drive solution for efficient space utilization.

The high-performance asynchronous drum motor with robust multi-stage planetary gear is integrated into the Interroll Roller based on Series 3950 and is applicable for loads of up to 1,250 kg per zone.

Construction of pallet conveyors requires minimal engineering: There is no need for complex motor stations; the pallet rollers are driven roller-to-roller. This compact and maintenance-free solution can be mounted directly on the floor.

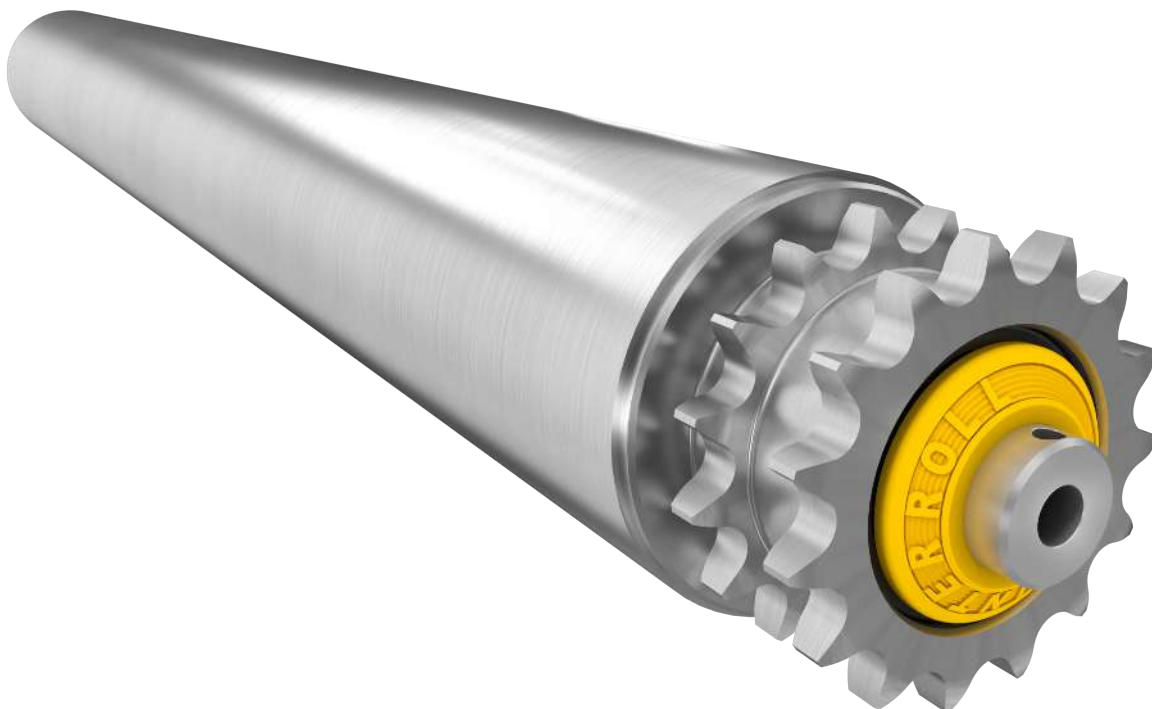

# DRUM MOTOR DP SERIES PALLET DRIVE 0080 / 0089

## Technical data

	DP 0080	DP 0089
Motor diameter	80 mm	89 mm
Max. speed	up to 0.2 m/s	up to 0.22 m/s
Drive head	Gear 5/8" z15 and z18	Gear 5/8" z15 and z18 Toothed belt 8 mm z25
EL min./max.	500 – 1,500 mm	500 – 1,500 mm
Power	70 W S3 50%	70 W S3 50%
Torque	22 Nm	22 Nm
Load	up to 1,250 kg	up to 1,250 kg
Throughput	120 pallets/hour	120 pallets/hour
Ambient temperature	-5 °C to +40 °C	-5 °C to +40 °C
Motor protection rate	IP54	IP54
Thermal controller	Bi-metal switch	Bi-metal switch

## Electrical data for 3-phase asynchronous motor

$P_N$ [kW]	$n_p$	$n_N$ [min <sup>-1</sup> ]	$f_N$ [Hz]	$U_N$ [V]	$I_N$ [A]	$\cos\varphi$	$\eta$	$J_R$ [kgcm <sup>2</sup> ]	$I_S/I_N$	$M_S/M_N$	$M_B/M_N$	$M_P/M_N$	$M_N$ [Nm]	$R_M$ [Ω]
0.07	2	2889	50	400	0.33	0.56	0.54	1.25	4.2	4	4.5	4	0.23	72.7
0.07	2	2889	50	230	0.57	0.56	0.54	1.25	4.2	4	4.5	4	0.23	72.7

$P_N$	= Rated power	$J_R$	= Rotor moment of inertia
$n_p$	= Number of poles	$I_S/I_N$	= Ratio of startup current – rated current
$n_N$	= Rated speed of rotor	$M_S/M_N$	= Ratio of startup torque – rated torque
$f_N$	= Rated frequency	$M_B/M_N$	= Ratio of pull-out torque – rated torque
$U_N$	= Rated voltage	$M_P/M_N$	= Ratio of pull-up torque – rated torque
$I_N$	= Rated current	$M_N$	= Rated torque of rotor
$\cos\varphi$	= Power factor	$R_M$	= Branch resistance
$\eta$	= Efficiency		

## Design variants and accessories

Options	Electromagnetic holding brake
Certificate	cULus safety certificates

# DRUM MOTOR DP SERIES PALLET DRIVE 0080 / 0089

## Dimensions

### Pallet Drive

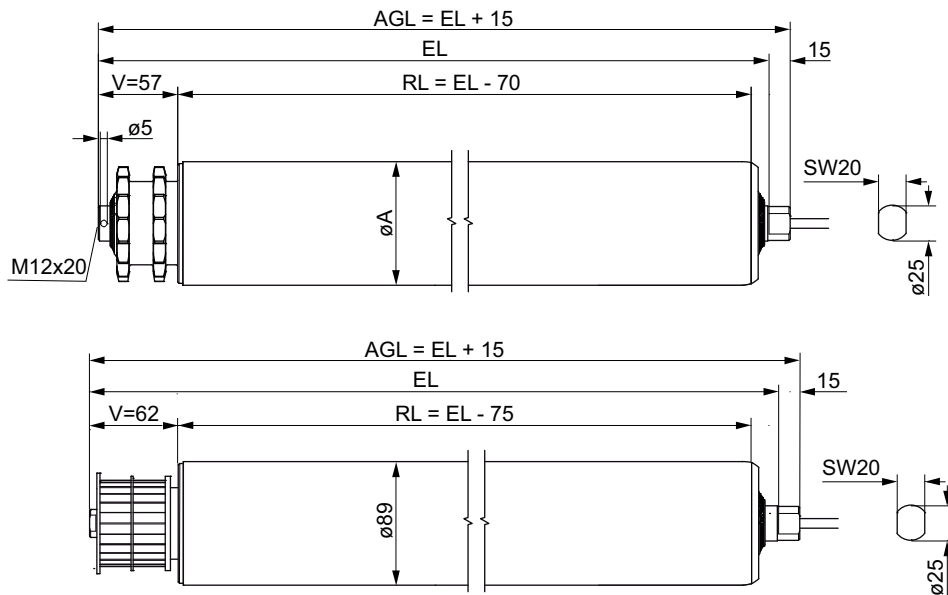

Type	A [mm]	EL [mm]	AGL [mm]
DP 0080	80.0	RL+V+13	RL+V+28
DP 0089	89.0	RL+V+13	RL+V+28

# DP SERIES

## CABLE OVERVIEW AND CONNECTION DIAGRAMS

### CABLE OVERVIEW

#### Cable overview

#### Cable types of DP series

#### Cable with 7 main cores

Article number	1107481
Cross section	0.5 mm <sup>2</sup>
Numeric code and color code	Numeric code + color code
Insulation conductors (main cores)	ETFE
Data cores (number)	2
Cross section	0.5 mm <sup>2</sup>
Numeric code and color code	Color code
Insulation conductors (data cores)	ETFE
Insulation of outer sheath	PVC
Halogen-free	No
Color of outer sheath	Gray
Shielded	Copper-tinned
Outside diameter	7.7 ± 0.2 mm
Operating voltage	600 V
Temperature range	-30 to +105 °C according to UL
Approval	cULus

# DP SERIES

## CABLE OVERVIEW AND CONNECTION DIAGRAMS

### CONNECTION DIAGRAMS

#### Connection diagrams

##### Abbreviations

ye/gn	= yellow/green	or	= orange
bn	= brown	vi	= violet
bk	= black	rd	= red
gy	= gray	wh	= white
bu	= blue	FC	= Frequency inverter for permanent magnet synchronous motors
TC	= Thermal controller (bi-metal switch)	NC	= Not connected
BR	= Electromagnetic brakes		

##### Rotation

**Note:** The rotational direction of the drum motor is shown on the connection diagrams. The rotation indicated is correct when looking at the motor from the connection side.

##### Cable connections 3-phase asynchronous motor

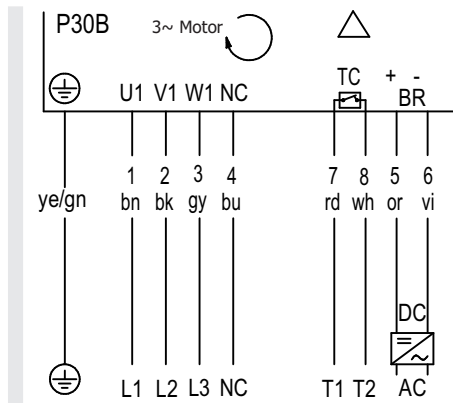

Fig.: With brake, 3-phase, 7+2 core cable, winding for 1 voltage, delta connection

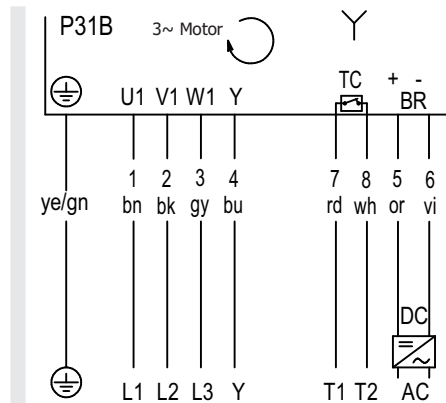

Fig.: With brake, 3-phase, 7+2 core cable, winding for 1 voltage, star connection

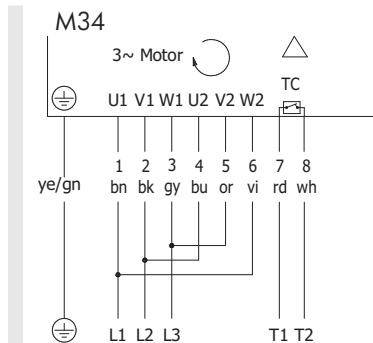

Fig.: 3-phase, 7+2 core cable, winding for 2 voltages, delta connection

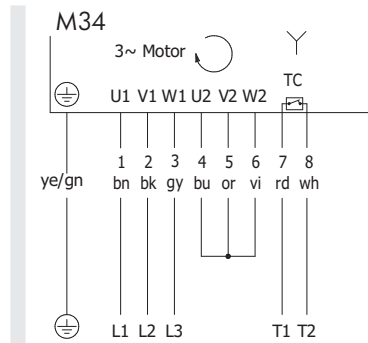

Fig.: 3-phase, 7+2-core cable, winding for 2 voltages, star connection



# DP SERIES OPTIONS AND ACCESSORIES ELECTROMAGNETIC BRAKES

## Electromagnetic brakes

The electromagnetic brake, which is available as an option, acts directly on the rotor shaft. If the power supply is interrupted, the brake is applied and holds the Pallet Drive in position until the power supply is re-established. The load held by the brake corresponds to the maximum transport weight specified for the Pallet Drive.

### Features:

- Applied directly to the rotor shaft of the Pallet Drive.
- Holds a load equal to the specified transport weight.
- Operating temperature from  $-10^{\circ}\text{C}$  to  $+120^{\circ}\text{C}$ .

### Technical data

Brake type	24
Rated braking torque	2 Nm
Rated power	11 W
Rated system voltage	24 V DC
Rated current	500 mA

The installed brake disk is a wear part and has a limited service life in relation to the operating conditions. In case of premature wear, the operating conditions must be checked and evaluated. The wear parts of the brake are not included in the product warranty.

All brakes are dimensioned for start/stop operation.

The rise and fall delays of the brakes can vary significantly depending on the following factors:

- Ambient temperature
- Internal operating temperature of Pallet Drive

# DP SERIES

## OPTIONS AND ACCESSORIES

### PALLET CONTROL PC 6000



#### Product description

Interroll is expanding its decentralized control and drive concept, which has been used successfully for years with the Interroll 24 V DC RollerDrive and the Interroll MultiControl for zero-pressure-accumulation unit load handling. Now, the portfolio also includes a special solution, the new Interroll Pallet Control PC 6000, for 400 V AC drive technology.

The new intelligent control unit serves as a link between the 400 V AC Pallet Drive and Interroll's proven 24 V MultiControl, which again provides the complete logic for zero-pressure-accumulation conveyors. However, this solution eliminates the need for centralized PLC cabling and PLC programming.

The integrated soft start function reduces the starting torque, which relieves the load on all mechanical components. This in turn provides optimum pallet acceleration. Pallet overrun after the Pallet Drive has been switched off is also regulated by Pallet Control.

The new control offers many functions and supports preventive maintenance. The Pallet Control Configurator, which can be downloaded from the Interroll website, allows to easily change parameters or modify the direction of rotation via the USB connection of the Pallet Control, without having to move and replug cables. Current and power can be monitored and the current status is displayed. In addition, the total operating time of the respective Pallet Drive is displayed, which allows to preventively arrange the necessary maintenance. This reduces maintenance requirements and possible downtimes to a minimum.

A thermal controller contact and continuous analysis of current consumption protect the Pallet Drive against overload. The optional brake in the Pallet Drive is also activated via Pallet Control. Alternatively, Pallet Control can be activated via other 24 V digital inputs or a 0 – 10 V DC analog input.



# DP SERIES OPTIONS AND ACCESSORIES PALLET CONTROL PC 6000

## Technical data

<b>Rated voltage</b>	3 x 400 V AC 50 Hz; 24 V DC
<b>Voltage range</b>	380 – 420 V AC 50 Hz; 22 – 26 V DC
<b>Current consumption</b>	Max. 3 A @ 400 V AC; max. 2 A @ 24 V DC Max. 10 A @ 400 V AC; max. 2 A @ 24 V DC
<b>Protection rate</b>	IP54
<b>Weight</b>	0.5 kg
<b>Ambient temperature in operation</b>	–28 °C to +40 °C (–22 °F to +104 °F)
<b>Ambient temperature during transport and storage</b>	–40 °C to +80 °C (–40 °F to +176 °F)
<b>Max. temperature change</b>	1 K/min, 3 h, 2 cycles
<b>Max. relative humidity</b>	93 % at +40 °C (+104 °F), 14 days, non-condensing
<b>Max. installation height above sea level</b>	1000 m. Installation in systems at an altitude above 1000 m (3300 ft) is possible in principle. However, this may result in lower performance values.

# APPLICATION NOTES

## APPLICATION PRINCIPLES

### Application principles

Most of the Interroll Drum Motors are used in unit handling conveyors that are transporting small packages, boxes, cardboard containers, small pallets or other material. Depending on the type of application, friction drive or positive drive belts can be used with asynchronous or with synchronous drum motors.

Examples of applications:

- Logistics, such as postal sorting and distribution centers
- Airport baggage handling
- Seafood, meat and poultry
- Bakeries
- Fruit and vegetables
- Beverage and brewing industry
- Snacks
- Weighing equipment for packages

### Friction drive belts



Friction drive belts are driven via the friction between drum motor and conveyor belt. The drum motor is normally crowned to prevent belt wander. The belt must be tensioned in order to transfer the torque from the drum motor. The top surface of the belt can be flat, plain or have a ribbed, grooved or diamond pattern.

### Lagging

Interroll offers a broad spectrum of hot and cold-vulcanized laggings made of different materials to increase the friction between belt and drum shell. For more information, page 108.

### Positive drive belts



Modular plastic belts, solid homogeneous belts, steel mesh or wire belts are positively driven, i.e., with no belt tension. Since the belt has hardly any direct contact with the drum shell, the heat dissipation is less effective in these applications. For applications of this type, we recommend the use of an efficient asynchronous drum motor with high efficiency or the use of a synchronous drum motor.

Positive drive belts use less power than friction drive belts, allowing longer conveyors. Because these belts are not tensioned, there is less stress on the bearings and internal parts of the drum motor resulting in a longer service life.

Interroll recommends the use of profiled lagging wherever possible to ensure easy cleaning, evenly distributed torque transmission and torque dampening at start-up. Interroll sprockets can be supplied for belts where profiled lagging is not suitable, page 134.

Interroll offers a wide range of profiled lagging according to the belt manufacturers' specifications. For more information, see lagging and coating page 108.

### Non-belt applications



For applications without a conveyor belt or with a narrow belt covering less than 70 % of the drum motor face width, heat from the motor can no longer be dissipated via the belt contact. For these applications, we recommend using a 2-pole asynchronous drum motor or synchronous drum motor with frequency inverter.

**Examples of non-belt applications include the following:**

- Pallet conveyor
- V-belt drive for driving roller conveyors
- Chain conveyor
- Narrow belts covering less than 70 % of the shell width

For some non-belt applications the drum motor can be mounted in a non-horizontal position. For more information, page 185.

## Ambient conditions

### Hygienic conditions



For food processing and other applications where hygiene is paramount we recommend the following materials, connectors and accessories:

- Stainless steel shell
- Stainless steel cover
- Stainless steel shafts
- External shaft seals made of PTFE
- Food grade synthetic oil
- NBR hot-vulcanized (FDA & EC 1935/2004)
- Molded PU, Shore hardness 82D (FDA & EC 1935/2004 only)
- A lagging of hot vulcanized NBR or molded PU should be combined only with a stainless steel shell.
- Diamond patterned lagging is not suitable for food processing applications.

### Cable connectors/terminal boxes and cables

All cable connectors, terminal boxes and cables are not included in our (EC) 1935/2004 and FDA declaration. These components are considered "Not in direct contact with food stuffs" as described in the following regulations: Commission regulation (EC) No. 2023/2006 of December 22, 2006 on good manufacturing practice for materials and articles intended to come into contact with food. Article 3, definition (d): "Non-food-contact side" means the surface of the material or article that is not directly in contact with food.

FDA Food Code 2009: Chapter 1 - Purpose and Definitions - "Food-contact surface" means

- (1) A surface of equipment or a utensil with which food normally comes into contact; or
- (2) A surface of equipment or a utensil from which food may drain, drip, or splash:
  - (a) Into a food, or
  - (b) Onto a surface normally in contact with food.

USDA & 3A: no compliance

For food processing applications, Interroll recommends using cable connectors and terminal boxes in stainless steel or Technopolymer.

### Hygienic design

All Interroll Drum Motors are designed in accordance with EU Directives for Hygienic Design:

- Machinery Directive (Directive 98/37/EC) Food Machinery section, Appendix 1, point 2.1 (to be replaced by 2006/42/EC)
- Document 13 EHEDG guideline for the hygienic design of machines for open processes

### EHEDG-compliant drum motors

Interroll Drum Motors configured with components listed below comply with EHEDG, Class I "Open Equipment". They are ideally suited for ultra-hygienic environments and tolerate high water pressure washing (IP69k):

- Stainless steel shell: cylindrical or crowned
- Stainless steel cover
- Stainless steel shafts
- Shaft seals made of PTFE
- Food grade synthetic oil

### Conveyor frame

EHEDG design rules recommend the use of rust-free open conveyor frames to facilitate easy cleaning, wash down and disinfection of the conveyor, drum motor and belt. The drum motor should be mounted in the conveyor frame in such a way that there is no metal-on-metal contact between motor shaft and frame support, .e.g. by using a rubber seal between shaft and frame support. The sealing material shall be FDA and EC 1935/2004 compliant.

### Cleaning materials

Cleaning specialist Ecolab has certified a 5-year minimum lifetime of materials used by Interroll when exposed to typical cleaning and disinfecting procedures using Ecolab's Topax range of products: P3-topax 19, P3-topax 686, P3-topax 56 and P3-topactive DES.



# APPLICATION NOTES

## AMBIENT CONDITIONS

### High pressure cleaning

Max. 80 °C / 80 bar for PTFE sealing with IP69k

**Note:** Changes in ambient temperature and humidity can cause condensation and lead to water inside the terminal box (especially in stainless steel terminal boxes). For example, this can occur when the motor is operated below 5 °C and then cleaned with hot water or steam. Interroll recommends using the cable option in such cases.

### High temperatures

Interroll Drum Motors are generally cooled by dissipating heat through the contact between the surface of the drum shell and the conveyor belt. It is essential that each drum motor has an adequate thermal gradient between the internal motor and its ambient operating temperatures.

All drum motors in the catalog are designed and tested in accordance with EN 60034 (without lagging and with a belt) for use at a maximum ambient temperature of +40 °C. Any material can be used, but stainless steel has less heat dissipation.

Lagging can cause thermal overload for positive driven belts. For this reason, use motors with frequency inverters that ensure an optimum temperature. As an alternative, it is also possible to use synchronous motors. Rubber lagging for friction drive belts can also cause thermal overload. External cooling systems can also be used to prevent thermal overload.

If you need a motor for applications with ambient temperatures above +40 °C, please contact Interroll.

### Low temperatures

When a drum motor is operated in low temperatures (below +2 °C), consider the viscosity of the oil and temperature of the motor while it is not running. For additional information and notes, please contact Interroll.

### Anti-condensation heating for asynchronous drum motors

In ambient temperatures below +1 °C, the motor windings should be heated to regulate the oil viscosity and to keep seals and internal parts at a constant temperature.

$$I_{DC} = \frac{U_{SH\Delta} \cdot 3}{R_{Motor} \cdot 2}$$

Fig.: Delta connection

If the motor current is switched off for some time and the ambient temperature is very low, then the motor oil becomes viscous. In these conditions problems may occur when starting the motor and at temperatures of around zero frost crystals can form on the sealing surfaces, causing oil leakage. To prevent these problems use anti-condensation heating.

The heater applies a DC voltage to the motor winding. This causes current to flow either in the two motor phases of a 3-phase motor or the main winding of a 1-phase motor. The amperage depends on the voltage applied and the winding resistance. This current creates a power loss in the winding which heats up the motor to a certain temperature. This temperature is determined by the ambient temperature and the amperage.

Information on the correct voltage is available in the motor version tables. The values listed are average values, which can be increased or decreased depending on the required motor temperature and the ambient temperature. Interroll strongly recommends determining the correct voltage by testing under actual operating conditions.

Only DC voltage may be used to heat the motor. The use of AC voltage can cause the motor to move unexpectedly, leading to serious damage or injury.

The stationary heating system should only be used when the motor is actually idle. The heating voltage must be switched off before the motor is operated. This can be ensured by using simple relays or switches.

The suggested voltages are calculated to prevent the formation of condensation. If the motor needs to be held at a specific temperature, then the stationary heating system must be set up accordingly. In this case, please contact your Interroll customer consultant.

The anti-condensation heating voltage must be connected to any two phases of a 3-phase motor. The heating current supplied by the heating system can be calculated as follows:

$$I_{DC} = \frac{U_{SH\star}}{R_{Motor} \cdot 2}$$

Fig.: Star connection

## Low noise



All Interroll Drum Motors excel with relatively low noise development and vibrations. The performance levels are not specified or guaranteed in this catalog because they can vary depending on the type of motor, number of poles, speed and application. For specific low-noise applications, please contact your Interroll customer consultant.

## Altitudes above 1,000 m

Operating a drum motor at an altitude of more than 1,000 m may result in power loss and thermal overload due to the low atmospheric pressure. This must be considered when calculating your power requirement. For more information, please contact your Interroll customer consultant.

## Supply voltage (asynchronous drum motors only)

### Using 3-phase 50 Hz motors in a 60 Hz supply system with the same voltage

- Motor rated: 230/400 V – 3 ph – 50 Hz
- Supply voltage: 230/400 V – 3 ph – 60 Hz

Using a 3-phase 50 Hz motor in a 60 Hz supply system will increase the frequency, and therefore the speed, by 20 %. If the other rated motor parameters are to be kept constant, a 20 % higher input voltage is required (U/f law). However, if this 20 % higher voltage is not supplied, all voltage-dependent parameters will be affected in accordance with the following table:

System voltage = rated motor voltage

Motor data			
Power	P	kW	100 %
Rated speed	$n_n$	1/min	120 %
Rated torque	$M_n$	Nm	83.3 %
Starting torque	$M_A$	Nm	64 %

### Motor data

Pull-up torque	$M_s$	Nm	64 %
Pull-out torque	$M_k$	Nm	64 %
Rated current	$I_N$	A	96 %
Starting current	$I_s$	A	80 %
Power factor	$\cos \varphi$		106 %
Efficiency	$\eta$		99.5 %

### Supply voltage

### Motor rated

230/400 V	230/400 V
3 ph	3 ph
60 Hz	50 Hz

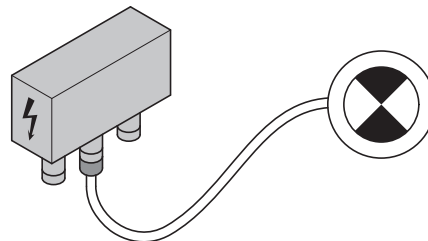

### Using 3-phase 50 Hz motors in a 60 Hz supply system with 15/20 % higher voltage

- Motor rated: 230/400 V – 3 ph – 50
- Supply voltage: 276/480 V – 3 ph – 60 – 2 and 4 poles (motor voltage + 20 %)

Using a 3-phase 50 Hz motor in a 60 Hz supply system with 20 % higher voltage will increase the frequency and therefore the speed by 20 %, but will maintain all the rated motor parameters subject to small variations (U/f law).

**Note:** If the supply voltage is increased by 15 % compared to the motor voltage, the actual motor output decreases to 92 % of the original motor output.

Supply voltage = 1.2 x rated motor voltage (for motors with 2 and 4 poles)

# APPLICATION NOTES INDUSTRIAL SOLUTIONS

Motor data			
Power	P	kW	100 %
Rated speed	$n_n$	1/min	120 %
Rated torque	$M_n$	Nm	100 %
Starting torque	$M_A$	Nm	100 %
Pull-up torque	$M_s$	Nm	100 %
Pull-out torque	$M_K$	Nm	100 %
Rated current	$I_N$	A	102 %
Starting current	$I_s$	A	100 %
Power factor	$\cos \varphi$		100 %
Efficiency	$\eta$		98 %

Supply voltage	Motor rated
230/480 V	230/400 V
3 ph	3 ph
60 Hz	50 Hz

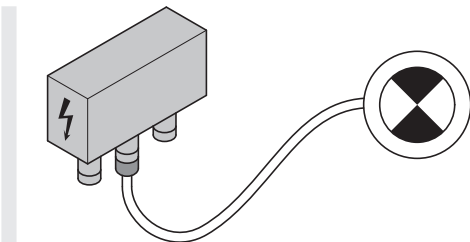

## Industrial solutions

Interroll offers a wide range of industrial solutions for its drum motors. In this chapter, only the most important solutions will be explained.

### General logistics

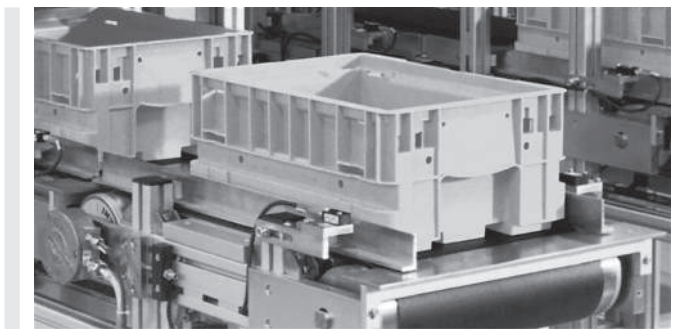

Conveying in logistics, warehousing and storage sectors covers a wide spectrum of applications in industries, such as electronics, chemicals, food, automotive and general manufacturing. All motors in this catalog are suitable for general logistics applications.

### High performance and dynamic conveying

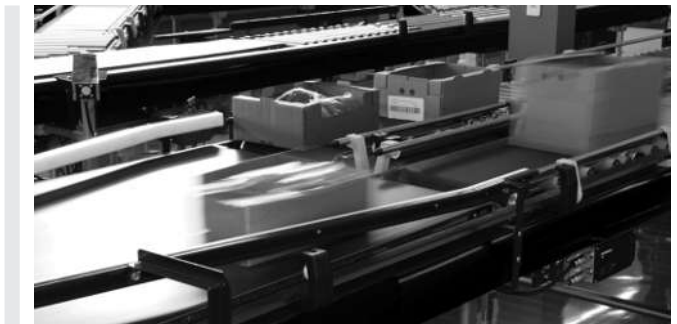

Modern Industry today expects high efficiency and increased productivity as well as fast bus communication between zones and zero maintenance. Interroll provides the perfect drives for high performance applications that typically use smart belts, packaging machines, weighing machines and sorting equipment. This type of equipment requires high torque, fast acceleration/ deceleration, dynamic braking and bus communication. If more control is needed, the motor can be fitted with an encoder to run it as a servo-drive.



### Food processing



Interroll Drum Motors are ultra-hygienic and easy to clean. All drum motors for food processing comply with EC 1935-2004 and FDA. Interroll is a member of the EHEDG (European Hygienic Engineering Design Group).

Consider the ambient conditions before choosing drum motor versions, options and accessories.

#### Suitable drum motors

- For friction drive belts use an asynchronous drum motor.
- For positive drive belts use either a drum motor for applications with positive drive belts or no belts, or an asynchronous drum motor with frequency inverter.
- A synchronous drum motor can also be used for all applications.

#### Torque transmission

For moist or wet food applications with friction drive belts Interroll recommends rubber lagging on the drum motor to improve the friction between the belt and drum shell. In continuously wet conditions, longitudinal grooved lagging can be used to dissipate the water flow and improve the grip.

#### Options and accessories

- Stainless steel or other materials approved for food or hygienic applications.
- Drum motors for food processing are supplied with food-grade oil.
- Interroll offers a variety of hot-vulcanized lagging materials approved for use in food processing (FDA and EC 1935/2004).
- Hot-vulcanized NBR and molded PU lagging has a longer service life, withstands higher torques and is easier to keep clean than cold-vulcanized lagging.

#### Conveyor frame

EHEDG design rules recommend the use of rust-free open conveyor frames to facilitate easy cleaning, wash down and disinfection of the conveyor, drum motor and belt. The drum motor should be mounted in the conveyor frame in such a way that there is no metal-on-metal contact between motor shaft and frame support, e.g. by using a rubber seal between shaft and frame support. The sealing material shall be FDA and EC 1935/2004 compliant.

#### Cleaning materials

Cleaning specialist Ecolab has certified a 5-year minimum lifetime of materials used for Interroll Drum Motors when exposed to typical cleaning and disinfecting procedures using Ecolab's Topax range of products: P3-topax 19, P3-topax 686, P3-topax 56 and P3-topactive DES.

#### Airport logistics



Airport applications, such as conveyors at check-in, X-Ray machines and scanning equipment, require low noise and frequent starts and stops. Most applications use friction drive belts made of PU, PVC or rubber.

#### Design guidelines

A belt conveyor is designed primarily to transport or transfer materials from one place to another. In its simplest form, a belt conveyor normally consists of a longitudinal frame with a drum motor at one end and an idler pulley at the other end around which a continuous belt revolves. The belt, which carries the materials, can be supported either by rollers or a steel, wood or plastic slider bed. This chapter on design guidelines is subdivided into two sections: friction drive belt conveyors and positive drive belt conveyors, since each type requires a different method of torque transfer.

# APPLICATION NOTES

## DESIGN GUIDELINES

### Friction drive belt conveyors

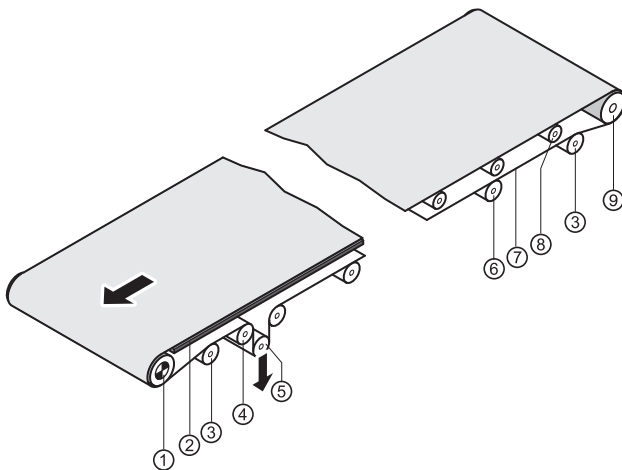

- |                     |                     |
|---------------------|---------------------|
| 1 Drum motor        | 6 Supporting roller |
| 2 Slider bed        | 7 Conveyor belt     |
| 3 Tie-in roller     | 8 Roller            |
| 4 Steering idler    | 9 Idler pulley      |
| 5 Tensioning roller |                     |

Friction drive belt conveyors, e.g. rubber, PVC or PU flat belts, rely on high friction between the drum motor and belt and sufficient belt tension in order to transmit the torque from the drum motor to the belt. For typical friction factors, refer to the table page 178.

#### Torque transmission

Normally the steel crowned shell of the drum motor is sufficient to transmit the torque but care must be taken not to over-tension the belt, which could damage the drum motor shaft bearings or even the belt itself.

#### Belt tension

The conveyor belt should only be tensioned in line with the manufacturer's recommendations and the tension should only be enough to drive the belt and load without belt slip. Over-tensioning can damage the drum motor and belt. Maximum belt tensions for the drum motors can be found in the product pages of this catalog.

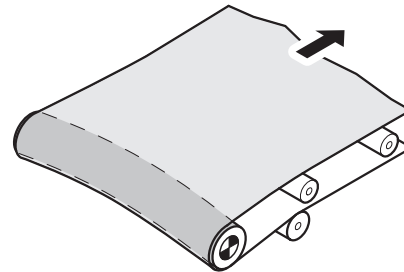

Fig.: Damaged drum motor due to over-tensioning

#### Lagging

To improve the torque transmitted from the drum motor to the belt, rubber lagging can be applied to the drum shell to produce more grip.

A smooth lagging or a lagging with diamond pattern is well suited for dry applications. It is also possible to use laggings with grooves or other laggings. Longitudinal grooved lagging is advisable to dissipate water in food processing or wet applications. Diamond patterned lagging can be used for non-food wet applications.

When external belt tracking devices are installed, cylindrical shells can be used to prevent opposing influences.

#### Additional friction factor

Depending on the belt material, the friction between conveyor belt and drum motor can vary.

Consider the following friction factors when calculating the belt tension:

Drum motor surface	Steel		Smooth lagging	Grooved lagging
	Dry	Wet	Dry	Wet
<b>Belt material</b>				
Frictioned rubber	0.25	0.20	0.30	0.25
PVC	0.35	0.25	0.40	0.30
Polyester fabrics	0.20	0.15	0.25	0.20
Impregnation with Ropanol	0.25	0.20	0.30	0.25

## Belt wrap angle

There is another way to improve the torque transmitted from the drum motor to the belt: You can increase the angle of belt wrap around the drum motor. The belt wrap angle is measured in degrees. A larger belt wrap angle gives better traction between the belt and drum motor, and the belt requires less belt tension. A minimum angle of  $180^\circ$  is generally recommended to transfer the full torque to the belt. Increasing the angle to  $230^\circ$  or more is indeed possible to reduce the belt tension and, therefore, the wear of drum motor and belt.

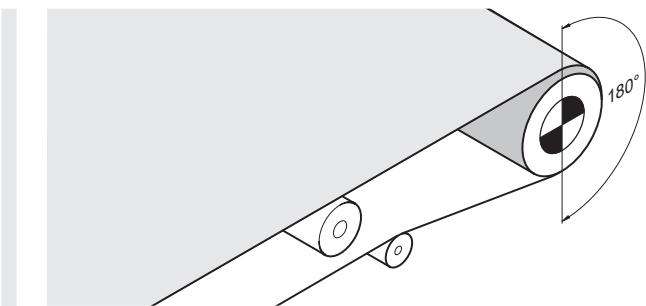

Fig.: Minimum belt wrap angle for friction drive belt conveyors

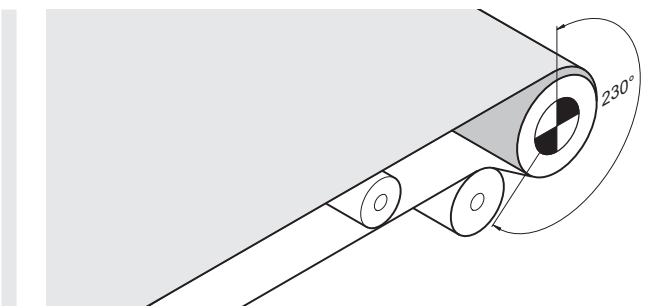

Fig.: Increased belt wrap angle for friction drive belt conveyors

## Roller bed conveyor

Due to their lower friction, roller bed conveyors require less power, less belt tension and are therefore more efficient than slider bed conveyors. Roller bed conveyors are especially suitable for longer conveyors with heavy loads.

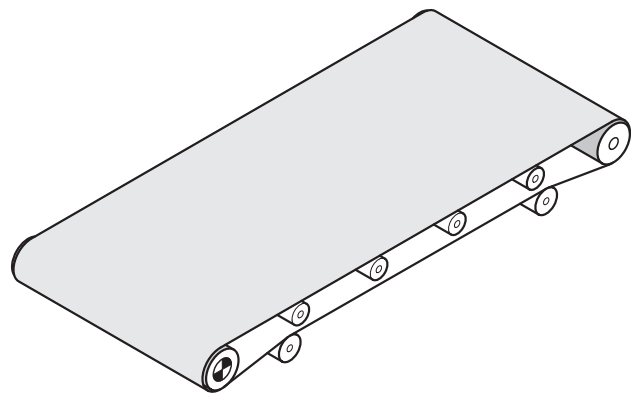

Fig.: Roller bed conveyor

## Slider bed conveyor

Belt conveyors using a slider bed have more friction and require higher power and belt tension than belt conveyors with rollers and are therefore less efficient. However, the transported goods lie on the belt with greater stability. Due to its simple construction, it is a lower cost option than the roller bed conveyor.

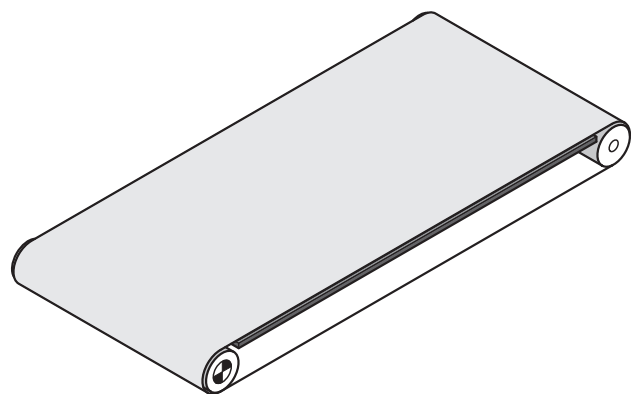

Fig.: Slider bed conveyor

## Drive positions

The drum motor is usually positioned at the head or discharge end of the conveyor but can be positioned elsewhere to suit the application or design.

# APPLICATION NOTES

## DESIGN GUIDELINES

### Head drive

The head drive positioning (discharge end) is the most common and preferred option for non-reversible conveyors and is ideal because it is simple to design and easy to install. Furthermore most of the belt tension is on the carrying side and allows the drum motor to transfer its full torque to the belt.

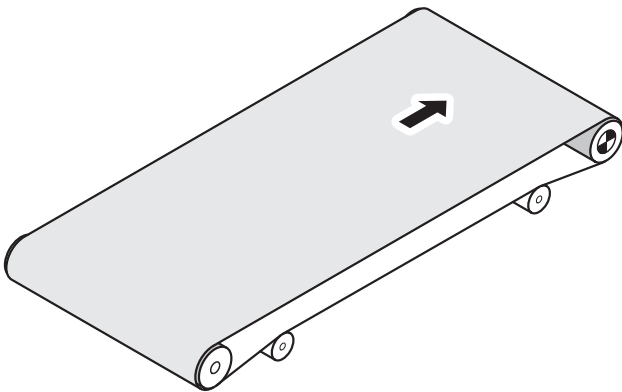

Fig.: Non-reversible conveyor with head drive

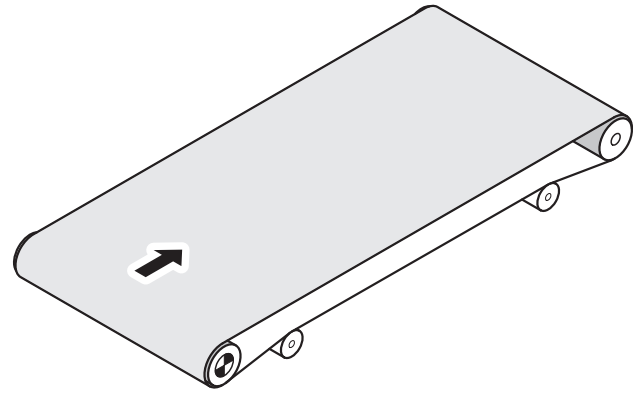

Fig.: Short friction drive belt conveyor with tail drive

### Center drive

A center drive can be used for longer belt conveyors where a large diameter drum motor is required and there is insufficient space available at the head end. The center drive can also be used for reversible conveyors because the belt tension is distributed more evenly between the carrying and return side of the belt. Belt tracking issues for forward and reverse operation can be minimized.

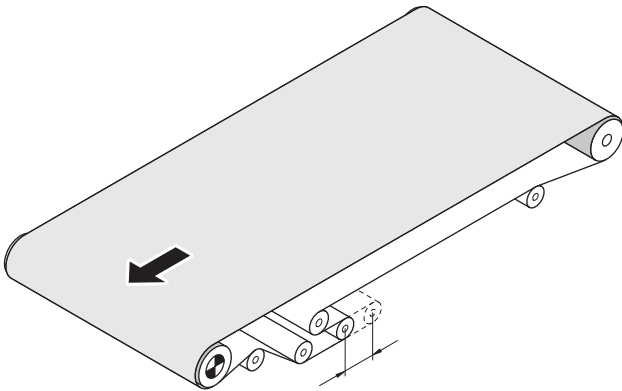

Fig.: Optional design for non-reversible long conveyor with center take-up

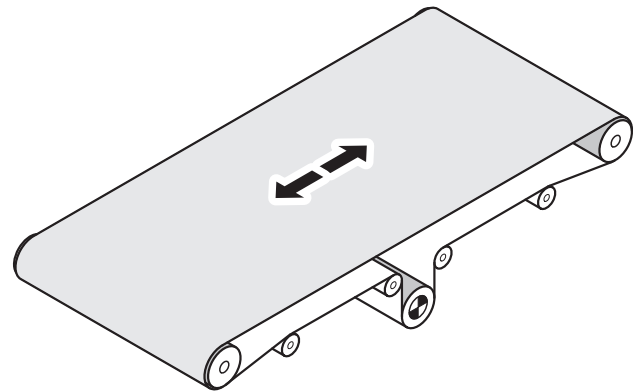

Fig.: Long belt conveyor with center drive

### Tail drive

A conveyor's tail end (loading or receiving end) is not the ideal drive position as the drum motor is pushing the carrying side of the belt and more tension is applied to the return side. Therefore, the full torque of the drive may not be applied. This type of drive can lead to belt waves (belt lifting on the top side), jumping and undesirable belt wander. If a tail drive is necessary, it is recommended only for use with short friction drive belt conveyors of 2 to 3 meters in length with light loads. (It is not recommended for positive drive belts.)

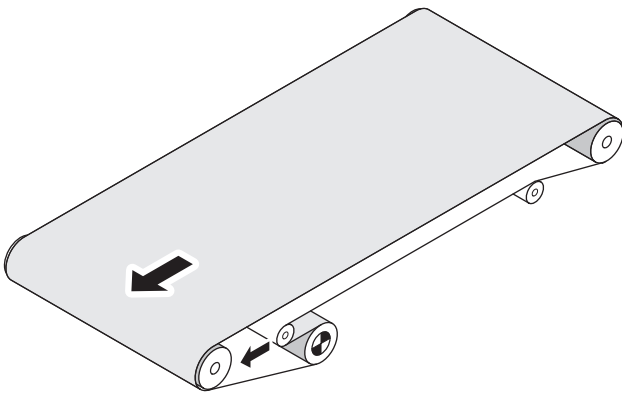
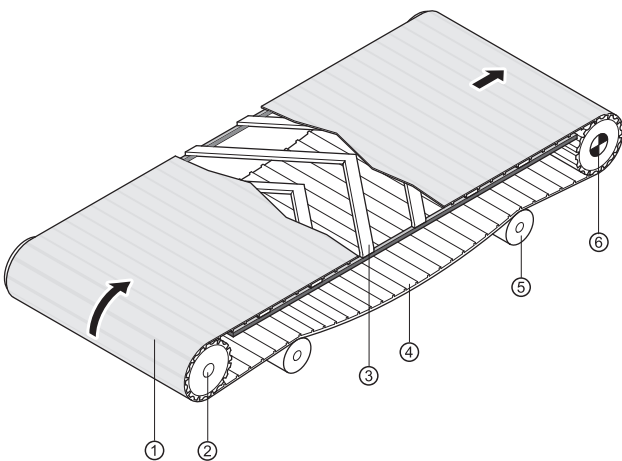

Fig.: Center drive for long belt conveyor with increased belt wrap

### Reversible drive

Interroll Drum Motors are suitable for reversing unless fitted with a backstop. However, the motor control must be designed in such a way that the drum motor is brought to a complete standstill before reversing, otherwise serious damage to the gear box could occur. Drum motors with a backstop may be used only for conveying in one direction. The direction is indicated by an arrow on the end housing.

### Positive drive belt conveyors



- 1 Modular plastic belt
- 2 Idler pulley with sprockets
- 3 Support slats
- 4 Catenary sag
- 5 Support rollers
- 6 Drum motor

Positive drive belt systems have a lower power consumption than friction drive belts, enabling longer conveyor constructions. As there is no belt tension, there is less stress on the drum motor bearings. Since the belt has no direct contact with the drum shell, the heat dissipation is less effective in these applications. For this reason, the drum motor should be used with a frequency inverter that is optimized for this application. Alternatively, motors for applications with positive drive belts or no belts can be used.

Examples of positive driven belts include the following:

- Modular plastic belts
- Positive drive solid homogeneous belts
- Steel slatted belts
- Steel mesh or wire belts
- Toothed belt
- Chain conveyor

Positive drive belt installations can be quite complex and are not discussed in detail in this catalog. Please refer to the belt supplier's instructions and contact Interroll if further advice is required.

### Torque transmission

Drum motors for positive drive belt conveyors are normally supplied with full-width machined rubber lagging that engages the profile of the conveyor belt on the underside. Alternatively, a cylindrical drum shell with a laterally welded key can be supplied enabling any type of steel, stainless steel or plastic sprocket wheels to be fitted to the shell. The number of sprockets depends on the belt width and load but there must be a minimum of three. The calculation of the number of sprockets required can be found in the belt manufacturer's catalog. Due to the thermal expansion of the belt, all sprockets supplied by Interroll are floating and therefore it may be necessary to guide the belt using side guides built into the conveyor frame in order to achieve a center belt tracking. As an alternative, Interroll can supply a fixed sprocket positioned in the center of the belt.

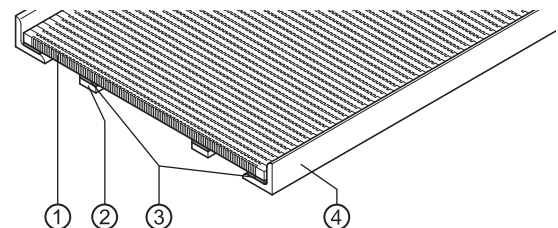

Fig.: Belt tracking

- 1 Belt
- 2 Support slats
- 3 Wear strips
- 4 Side supports/side guides

# APPLICATION NOTES

## DESIGN GUIDELINES

### Belt tension

Due to its positive drive, the conveyor belt generally requires no belt tension and uses only the gravity from its own weight to engage the lagging or sprocket profile. On the return side, the belt should hang loose to accommodate the changing length of the belt due to thermal expansion and contraction. The installation and conveyor design should comply with the belt manufacturer's recommendations.

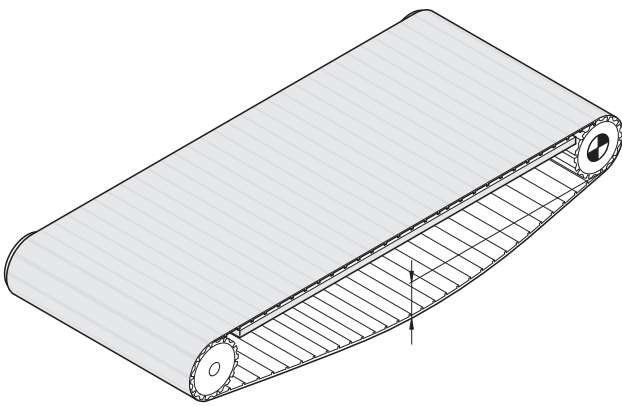

Fig.: Short conveyor without support rollers on the return belt

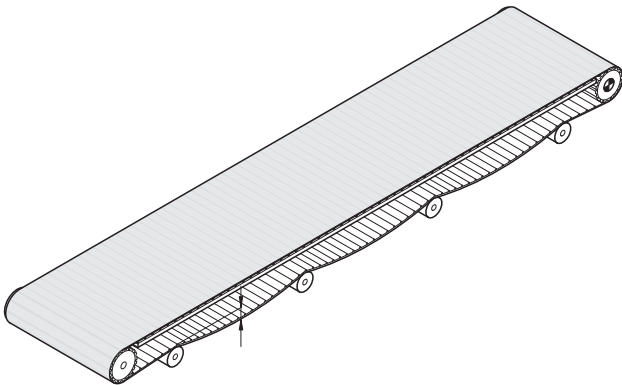

Fig.: Medium and long conveyor with catenary sag and support rollers on the return belt

### Velocity factor

The increased diameter of the drum motor when fitted with lagging or sprockets will affect the rated speed of the motors shown in this catalog. In order to calculate the final belt speed, please use the following calculation. The velocity factor VF can be found in the Options section, page 113.

$$V_{\text{belt}} = V_{\text{dm}} \times VF$$

$V_{\text{belt}}$  = Belt speed                      VF = Velocity factor  
 $V_{\text{dm}}$  = Rated speed of drum motor

The torque is transmitted directly from the drum shell via the lagging or indirectly through the key and sprockets to the belt. This transfers up to 97 % of the mechanical output onto the belt. In start-stop applications, the use of a soft start function or frequency inverter will increase the lifespan of the belt, sprockets and gear box.

### Belt pull correction factor

When using lagging or sprockets, the rated belt pull of the drum motor will be reduced. The actual belt pull is calculated as follows:

$$\text{Corrected belt pull} = \text{Rated belt pull} / VF$$

### Drive positions

For positive drive belt conveyors either a head drive or center drive is possible.

#### Head drive

The drum motor should be positioned at the head (discharge end) of the conveyor so that the carrying side of the belt is pulled under tension.

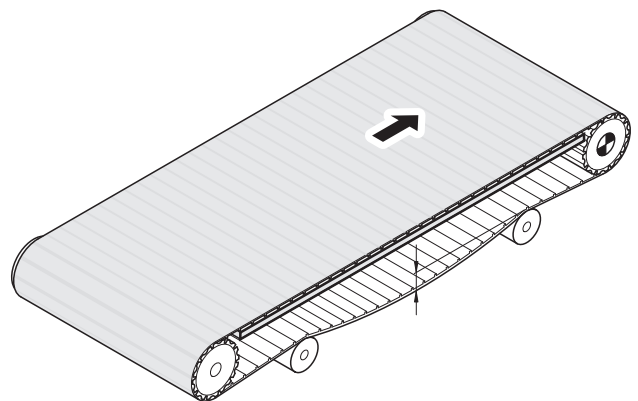

Fig.: Head drive for positive drive belt conveyors

#### Tail drive

Tail drives are not recommended. If the drum motor is located at the tail end (loading side) of the conveyor and attempts to push the belt, then the belt tension at the return belt is greater than at the carrying side of the belt. The belt "jumps" over the profile of the lagging or the sprockets and forms buckles in the excessive belt length – a safe transport of the material is no longer ensured.

#### Center drive

Center drives can be used for long unidirectional conveyors or for reversible conveyors. In the case of reversible conveyors, great care and attention is required for their design. Please contact the belt manufacturer for advice.

### Other conveyors

#### Inclined conveyor

Inclined conveyors require more power and higher belt tension than horizontal conveyors to move the same load. A backstop should be considered for single direction inclined conveyors to prevent rollback of the belt and load.

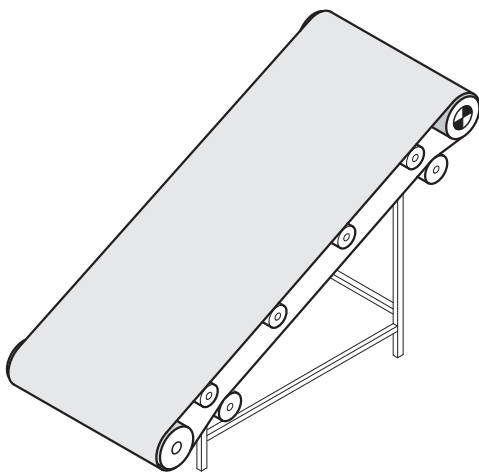

Fig.: Inclined conveyor

#### Reversible inclined or declined conveyors

An electromagnetic brake should be considered to prevent accidental reversal and rollback of the belt and load. To reduce acceleration and over-run of the belt and load on a declined conveyor calculate the power required as for an inclined conveyor.

#### Knife-edge conveyor

Knife edges reduce the gap between the transfer points of two conveyors. However, with friction drive belt conveyors, knife edges can severely increase the belt pull and tension required to overcome the increased friction between belt and knife edge. To reduce this friction the belt transfer angle should be increased as much as possible and a roller with a small diameter should replace the knife edge.

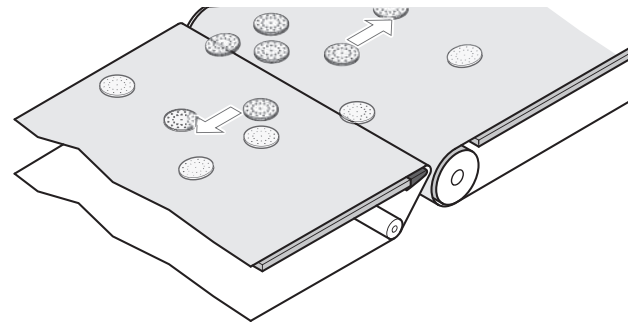

Fig.: Knife-edge conveyor

#### Food processing conveyors

EHEDG design rules recommend the use of rust-free open conveyor frames to facilitate easy cleaning, wash down and disinfection of the conveyor, drum motor and belt.

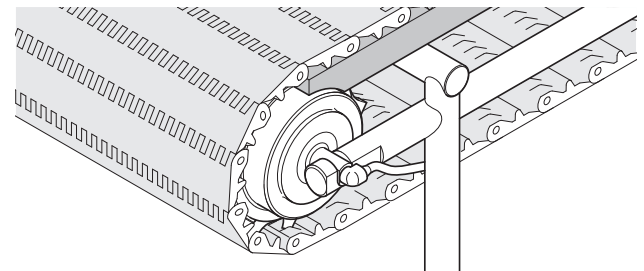

Fig.: Open conveyor design for hygienic cleaning

#### Plough and diverter units

If the drum motor is installed in a plough or diverter unit, it is frequently installed in a vertical position. This requires ordering a special motor design.

#### Frequent starts/stops

Frequent starts and stops can cause thermal overload of the motor and premature wear of the gear box, reducing the lifespan of the drum motor. In applications such as these, Interroll recommends the use of a frequency inverter to optimize the heat loss of the motor and a soft-start function to reduce the start-up load on the gear box. Synchronous or asynchronous drum motors with a frequency inverter are ideal for these applications.

# APPLICATION NOTES

## DESIGN GUIDELINES

### Controls

Interroll supplies brakes, backstops, encoders and frequency inverters for its range of drum motors.

#### What drive control system do you need?

As with any drive system, when you select a drum motor, you also must decide on the type and scope of control you will need to optimize your application. You should therefore select a motor and control system that ensures efficient and trouble-free operation right from the outset. Interroll offers a series of user-friendly drive and control solutions in its standard product range.

#### Overview of controls for AC asynchronous motors

	Direct connection to power supply	Frequency inverter from third parties or servo driver
Direct connection to power supply	●	
Voltage-controlled frequency		●
Sensorless vector control		●
Control loop closed		●

#### Overview of controls for AC asynchronous permanent magnet motors

	Frequency inverter from third parties or servo driver	Frequency inverter or servo driver recommended by Interroll
Direct connection to power supply		
Voltage-controlled frequency		
Sensorless vector control	●	●
Control loop closed	●	●

### Speed setting

The asynchronous drum motor and therefore the conveyor belt speed will be influenced by the load, belt tension and rubber lagging thickness. Speeds provided in the product pages are based on rated load and accurate to  $\pm 10\%$ ; for more accurate speeds use a frequency inverter/drive control to overcome these influences. For precise speeds use a frequency inverter/drive control combined with an encoder or other feedback device. Frequency inverters can also be used with asynchronous motors to increase the rated speed. However, the available torque will then be reduced starting at a frequency of 50 Hz. Synchronous drum motors with a suitable frequency inverter will offer solutions for most of these issues and can increase performance, throughput and efficiency.

For asynchronous drum motor brakes and backstops, see page 137.

#### Merges transfers and in-feed control

For asynchronous drum motors use a frequency inverter with DC braking (with or without encoder) to control the merge process. Alternatively, for precise, dynamic control and/or high throughput, use a synchronous drum motor.

#### Feedback system

Use an integrated encoder or other feedback device for precise speed and positioning data (see page 145).



## Operating modes

The following operating modes comply with IEC 60034-1.

### Continuous running duty S1

Operation at constant load which is long enough to reach a thermal steady-state condition.

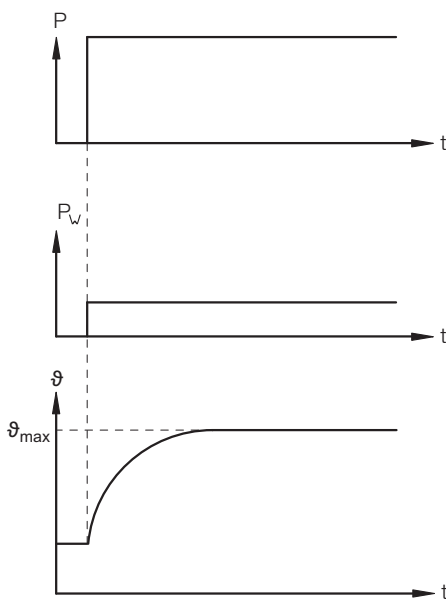

P	= Power input
$P_w$	= Electrical losses
$\vartheta$	= Temperature
$\vartheta_{max}$	= Max. temperature achieved
t	= Time

The majority of Interroll Drum Motor windings with an efficiency of over 50 % are suitable for operating mode S1 and continuous running duty. Please refer to the electrical data tables for standard motors and motors for applications with positive drive belts or no belts. The value is listed with the symbol  $\eta$  for efficiency.

### S2 to S10

For operating modes S2 to S10, consider the duty cycles and consult Interroll.

## Mounting requirements

### Horizontal mounting

A drum motor is normally mounted horizontally – parallel to the idler pulley and perpendicular to the conveyor frame – to ensure that the belt will run centrally without belt wander.

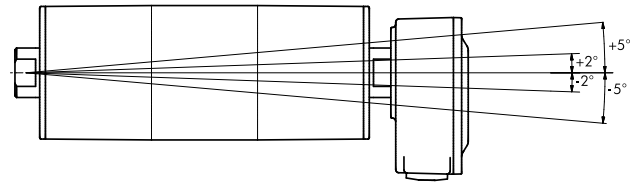

All drum motors must be mounted within  $\pm 5^\circ$  of the horizontal.

### Non-horizontal mounting

This requires a special motor design. The cable connection must always be at the top and a specific volume of oil is also needed for non-horizontal drum motors.

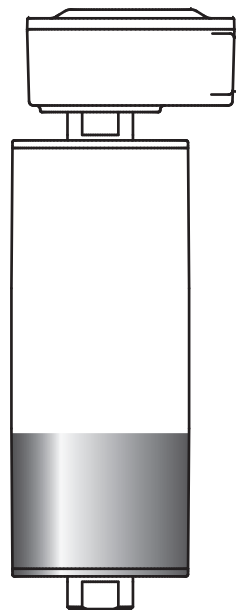

### Examples

- Carton turning
- Plough transfer units
- Deflector conveyors

### Mounting brackets

The mounting brackets must be strong enough to withstand the drum motor belt pull and its start-up torque. They must be fully supported and fastened to the conveyor frame so that the shaft ends do not move or deform. Shaft end key flats must always be fully supported by the brackets.

Use the mounting brackets specified for each drum motor model – see accessories starting at page 149.

# APPLICATION NOTES

## DESIGN GUIDELINES

### Axial play

The axial play between the shaft key flats and the mounting brackets must be 1.0 mm to allow for component heat expansion.

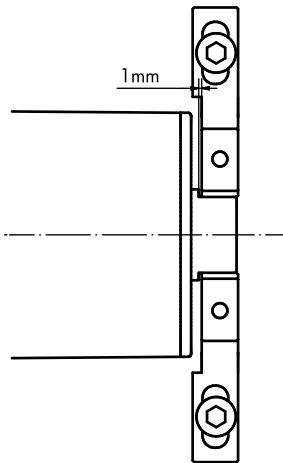

Fig.: Maximum axial play

### Torsion play

The torsion play between the shaft key flats and the mounting brackets must be no more than 0.4 mm.

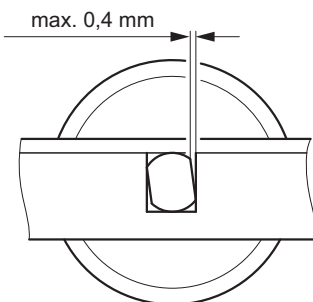

Fig.: Maximum torsion play

There must be no clearance between the shaft key flats and mounting bracket if the drum motor is to be used for frequent reversible operations or a large number of starts and stops.

### Supported length

At least 80 % of the key flats must rest on the mounting bracket.

### Other mounting devices

The drum motor can also be installed directly in the conveyor frame without mounting brackets. In this case, the shafts must rest in recesses in the conveyor frame that have been reinforced accordingly to meet all of the conditions listed above.

### Belt adjustment

Drum motors for friction drive belts are normally supplied with crowned shells in order to ensure central belt tracking and prevent misalignment of the belt during operation. However, the belt must be checked and adjusted at its initial start up and maintained as necessary.

### Diagonal check

The conveyor side frames must be parallel to each other and level on both sides ensuring the drum motor fits exactly at 90 degrees square to the frame.

This can be checked using the following procedure:

- The difference in length of the two diagonals must not be more than 0.5 %.
- The diagonals are measured from the drum motor shaft to the idler pulley shaft or from belt edge to belt edge.

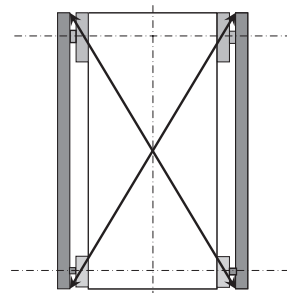

Fig.: Diagonal check

### Belt position

The underside of the belt should be flush with the conveyor slide or roller bed and must not be more than 3 mm above these.

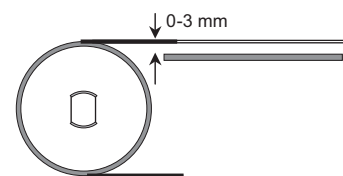
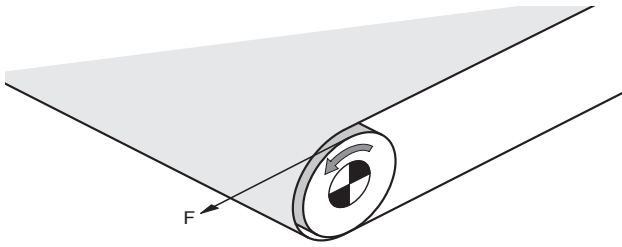

Fig.: Maximum distance between belt and conveyor bed

Misaligned drum motors, belts or idler pulleys may cause high friction and overheat the drum motor. This may also result in premature wear of the belt and lagging.

## Belt pull

The rated belt pull, power and speed for each drum motor version are shown in this catalog.



You can calculate the belt pull  $F$  using the following formulas.

The formulas are only intended as guidelines since they are based on typical operating conditions. The effect of additional friction from the following factors is not taken into account:

- Hopper
- Rubber seals
- Cleaning devices, such as ploughs, scrapers and brushes
- Friction between the product and side guides

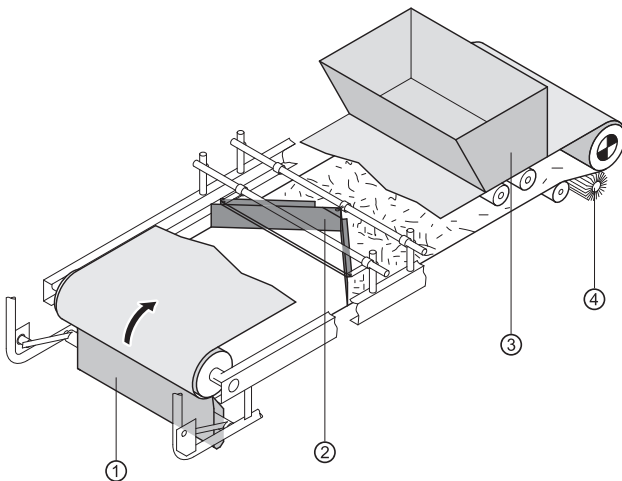

- 1 Scraper
- 2 Plough
- 3 Hopper
- 4 Brush

## Belt pull calculation ( $F$ ) according to the conveyor system





$$F = F_0 + F_1 + F_2 + F_3 + \text{safety factor}$$

Please add a safety factor of 20 % to this calculation.

<b>Roller bed conveyor</b>	
	$F_0 = 0.04 \cdot g \cdot L \cdot (2 P_n + P_{pr})$
Force without load	
	$F_1 = 0.04 \cdot g \cdot L \cdot P_{m1}$
Force to convey goods horizontally	
	$F_2 = g \cdot H \cdot P_{m1}^*$
Force to convey goods on incline	
	$F_3 = g \cdot L \cdot P_{m1} \cdot C_1$
Accumulation	
<b>Slider bed conveyor</b>	
	$F_0 = g \cdot L \cdot P_n \cdot C_2$
Force without load	
	$F_1 = g \cdot L \cdot P_{m1} \cdot C_2$
Force to convey goods horizontally	
	$F_2 = g \cdot H \cdot P_{m1}^*$
Force to convey goods on incline	
	$F_3 = g \cdot L \cdot P_{m1} \cdot C_1$
Accumulation	

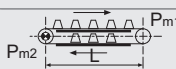
# APPLICATION NOTES

## DESIGN GUIDELINES

Double slider bed conveyor	
	
	$F_0 = g \cdot L \cdot P_n \cdot (C_2 + C_4)$
Force without load	
	$F_1 = g \cdot L \cdot (P_{m1} \cdot C_2 + P_{m2} \cdot C_4)$
Force to convey goods horizontally	
	$F_2 = g \cdot H \cdot (P_{m1} - P_{m2})^*$
Force to convey goods on incline	
	$F_3 = g \cdot L \cdot (P_{m1} \cdot C_1 + P_{m2} \cdot C_3)$
Accumulation	

- $P_n$  in kg/m = Belt weight per meter
- $P_{pr}$  in kg/m = Weight of rotating parts of the belt conveyor (carrying and return section) per meter length
- $P_{m1}$  in kg/m = Weight of the conveyed product on the carrying section, for each meter of length of the belt conveyor
- $P_{m2}$  in kg/m = Weight of the conveyed product on the return section, for each meter of length of the belt conveyor
- $C_1$  = Coefficient of friction between product and carrying side \*\*
- $C_2$  = Coefficient of friction between carrying side and slider bed \*\*
- $C_3$  = Coefficient of friction between return side and product \*\*
- $C_4$  = Coefficient of friction between return side and slider bed \*\*
- $L$  in m = Center-to-center length
- $H$  in m = Height difference in conveyor
- $F_0$  to  $F_3$  in N = Belt pull components for operating conditions shown
- $g$  in  $m/s^2$  = 9.81

\* The value  $F_2$  is negative with declined conveyors. However, to prevent over-run acceleration due to gravity,  $F_2$  should be positively calculated as for inclined conveyors.

\*\* Information about friction factors page 178.

### Coefficient of friction

Belt material	Slider bed material $C_2, C_4$	
	PE	Steel
PE	0.30	0.15
PP	0.15	0.26
POM	0.10	0.20

Belt material	Slider bed material $C_2, C_4$	
	PE	Steel
PVC/PU		0.30
Polyamide or polyester		0.18
Rubber	0.40	0.40

Belt material	Product material $C_1, C_3$		
	Steel	Glass, Technopolymer	Technopolymer
PE	0.13	0.09	0.08
PP	0.32	0.19	0.17
POM	0.20	0.15	0.15
PVC/PU	0.30		0.30
Polyamide or polyester	0.18		0.17
Rubber	0.40		0.40

### Belt tension

The following must be observed when calculating the belt tension:

- Length and width of conveyor belt
- Belt type
- Check the belt tension required to transport the load
- Check the belt elongation necessary for the installation. Depending on the load, the belt elongation for the assembly should be between 0.2 – 0.5 % of the belt length.
- The values for the belt tension and elongation are available from the belt manufacturer.
- Ensure that the required belt tension does not exceed the maximum belt tension (TE) of the drum motor.

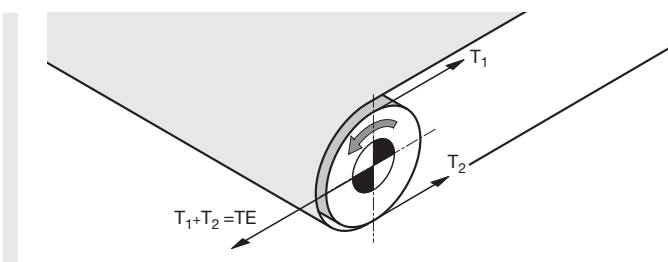

The required belt tension T1 (top side) and T2 (bottom side) can be calculated in accordance with DIN 22101 or the CEMA standard. Based on the information from the belt manufacturer, the actual belt tension can be roughly determined by a measurement of the belt elongation during tensioning.

The maximum allowable belt tension (TE) of each drum motor is specified in the drum motor tables in this catalog. Belt type, belt thickness and drum motor diameter must match the information from the belt manufacturer. If the diameter of the drum motor is too small, damage to the belt can result.

If the belt tension is too strong, it can damage the shaft bearings and/or other internal components of the drum motor and shorten the service life of the product.

## Belt elongation

The belt tension is created by the force of the belt when it is stretched in longitudinal direction. To prevent damage to the drum motor, it is absolutely necessary to measure the belt elongation and to determine the static belt tensioning force. The calculated belt tension must be equal to or lower than the values specified in the drum motor tables in this catalog.

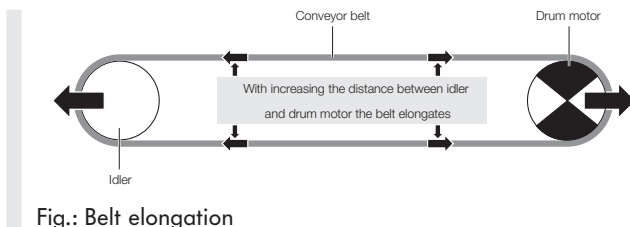

Fig.: Belt elongation

## Measuring the belt elongation

The belt elongation can very easily be determined using a measuring tape. Mark the not-tensioned belt on two points in the belt center, where the outer diameter of the drum motor and idler pulley is the biggest due to the crowning. Measure the distance between the two marks parallel to the belt edge (Be0). The longer the distance between the two marks, the more precise the measurement of elongation will be. Now start to tension the belt and adjust it. Once the belt is adjusted and tensioned measure the distance between the two marks again (Be). The belt elongation increases the distance.

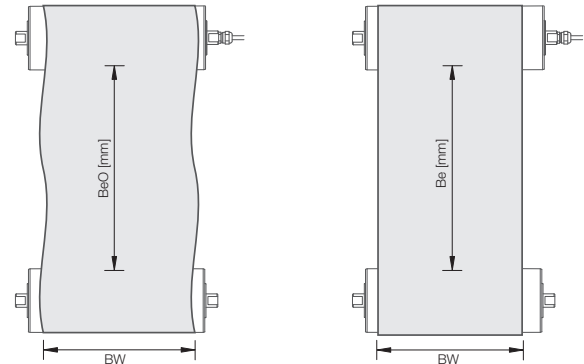

Fig.: Measuring the belt elongation

## Belt elongation calculation

With the belt elongation measurement you can calculate the belt elongation in %.

$$B_{e\%} = \frac{B_e \cdot 100\%}{B_{e0}} - 100$$

Fig.: Formula for calculating the belt elongation in %

For the calculation of belt elongation, the following values are needed:

- Belt width in mm (BW)
- Static force per mm belt width with 1 % elongation in N/mm (k1 %). This value is usually given in the belt data sheet or can be requested from the belt supplier.

$$TE_{[static]} = BW \cdot k1\% \cdot B_{e\%} \cdot 2$$

Fig.: Formula for calculating the static belt tensioning force in N

## Load and loading method

- Consider the method of loading, such as a feed conveyor, hopper loading or shock loading, and adjust the required belt pull and belt tension accordingly
- Consider the type and length of the load with regard to specific point loads and ensure that the weight of the point load (in Newtons) never exceeds the maximum belt tension (TE) of the drum motor.

# APPLICATION NOTES

## DESIGN GUIDELINES

### Drum motor diameter

- Choose the drum motor with the smallest diameter, but with due consideration of all application parameters and ambient conditions
- Check the minimum flexing diameter allowed for the belt and choose the drum motor diameter accordingly

All belts have a safe minimum diameter for normal or back flexing when used with drum motors or idler pulleys. Always refer to the belt manufacturer's specification for this information and choose the drum motor diameter accordingly, otherwise serious damage to the belt or drum motor may result. If the drum motor diameter is too small, insufficient torque will be transmitted to the belt and belt slip or "jumping" may occur.

To illustrate: The belt shown below has cross cleats and side frames and requires a larger diameter of drum motor than would be required for a plain flat belt.

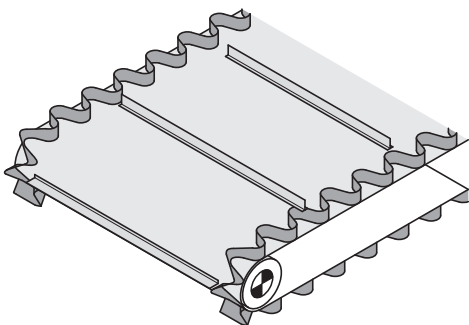

### Single phase asynchronous motors

Single phase AC motors are typically used when 3-phase voltage is not available.

#### Principle

Single phase AC motors have a main winding and an auxiliary winding to create a rotating field. The phase shift between the main and auxiliary phase is created by a permanently connected running capacitor.

#### Starting torque/starting capacitors

The starting torque can be very limited because of the imperfect rotating field:

- The starting torque of a 3-phase AC motor is typically 120 – 410 % of rated torque
- The starting torque of a 1-phase AC motor is typically 65 – 115 % of rated torque

Some 1-phase AC motors – especially in the higher power range – need an additional starting capacitor to reach a starting torque of 150 – 200 % of the rated torque. This starting capacitor should be the same size as the running capacitor and has to be switched parallel to it. This should be done ideally via a current-dependent switch relay during the start-up sequence of the motor. When the right torque/current has been reached, the starting capacitor is switched off by the relay. The capacity value of the running capacitor is always stated on the motor type label.

#### Noise

1-phase motors generally have a higher noise level at zero-load operation compared to 3-phase motors, because of the difference in the rotating field. Typically there is an erratic noise that increases steadily. This does not affect the operation of the drum motor and will normally disappear when belt tension is applied or the drum motor is run under load. Claims cannot be accepted due to this noise effect.

#### Capacitors and relays

All capacitors must be ordered separately for single phase drum motors. A suitable current-dependent relay to convert the starting capacitor to a running capacitor can be supplied if needed. For more information, please contact your Interroll customer consultant. The correct installation of the starting capacitor is shown in the wiring diagram supplied with the drum motor.

Interroll strongly recommends the use of 3-phase motors, since they are more efficient and save energy. Improved efficiency can be achieved by using a 3-phase motor with a frequency inverter. If a single phase supply is the only option, consider using a 3-phase motor together with a frequency inverter that converts the single phase input voltage into a 3-phase output voltage.

Standard Interroll capacitors	Article number
3 $\mu$ F	1100692
4 $\mu$ F	1000477
6 $\mu$ F	1100821
8 $\mu$ F	1100724

**Note:** Capacitors can have different service lives. Use only B rated capacitors.

### Final design steps

Before deciding on the final design, additional factors, such as the motor's switching frequency, still must be taken into account. When using an asynchronous drum motor for stop/starts of more than one per minute, a frequency inverter with a ramp time  $\geq 0.5$  s should be considered. Alternatively, use a synchronous drum motor and frequency inverter. Choose the drum motor version with the required belt pull, belt tension, diameter and speed for your application. If you cannot find the required speed in the drum motor tables, use a frequency inverter and choose the drum motor version with the closest speed or contact Interroll. The Belt Drive Matchmaker at [www.interroll.com](http://www.interroll.com) provides support in the selection of the correct drum motor.

### Material specification

#### Protection rate

Interroll drum motors are provided with IP69k protection as standard.

Protection against solid bodies	
IP, first number	Definition
5	Dust-protected
6	Dust-tight
Protection of internal equipment against harmful ingress of water	
IP, second number	Definition
4	Protected against spray water
5	Protected against water jets (P1 nozzle 6.3 mm, water delivery rate 12.5 l/min $\pm 5$ %)
6	Protected against water jets similar to marine swells (P2 nozzle 12.5 mm, water delivery rate 100 l/min $\pm 5$ %)
7	Ingress of water in quantities causing harmful effects shall not be possible when the enclosure is temporarily immersed in 1 m water under standardized conditions of pressure and time
9k	Protected against the effects of high-pressure liquids: <ul style="list-style-type: none"> <li>• Test with fan nozzle</li> <li>• Test unit on turntable (5 revolutions/minute)</li> <li>• Water delivery rate 14 – 16 l/min</li> <li>• Water pressure about 8,000 to 10,000 kPa at <math>80 \pm 5</math> °C with a duration of 30 s per position</li> <li>• Water aimed at the housing with increased pressure from any direction must not have any damaging effect</li> </ul>

### Lagging

#### NBR

This type of synthetic rubber has good wear characteristics, excellent resistance to oil, fuel, and other chemicals. On top of that, it is also easy to clean. Its resilience makes NBR the perfect material for the rubber lagging of drum motors. It can be used in most material handling applications. NBR withstands temperatures from -40 to +120 °C, nitrile rubber is generally resistant to aliphatic hydrocarbons but, like natural rubber, can be attacked by ozone, aromatic hydrocarbons, ketones, esters and aldehydes. White NBR is accepted for the food processing industry and is offered with FDA and EC1935/2004 approval.

#### PU

PU represents any polymer consisting of a chain of organic units joined by urethane (carbonate) links. It is tear-resistant and is superior to rubber. Polyurethane has outstanding resistance to oxygen, ozone, sunlight and general weather conditions. Most PU formulations offer an extremely long lifespan, good resistance to heat and cold at temperatures of between -35 and +80 °C and is offered with EC 1935/2004 and FDA approval.

**Note:** Minimum PU thickness 4 mm, maximum shell length (SL) 1,200 mm.

#### Hot vulcanization

Hot vulcanized NBR rubber lagging can be used to increase friction between the drum motor and conveyor belt for high torque applications and to reduce belt slip. Alternatively, it can be profiled to drive modular belts and other special applications. Due to the high temperature of the process, the lagging must be applied to the shell before the drum motors are assembled. The result is a very strong bonded rubber, suitable for high torque applications and completely sealed to the shell. This method guarantees a long service life and is recommended for hygienic applications.

NBR profiled lagging is not recommended for use with solid homogeneous belts due to the high friction that can cause the belt to jump.

#### Cold vulcanization

Cold vulcanized NBR rubber lagging is used to increase the friction between the drum shell and belt in order to reduce belt slip. The cold process requires a special adhesive to glue the lagging onto the drum shell. Cold vulcanized white NBR is approved by the FDA. The lagging follows the original shape of the drum shell (crowned or cylindrical) and is not machined afterwards. However, the process can be applied quickly to finished assembled drum motors and therefore is a quick and easy solution.

# APPLICATION NOTES

## MATERIAL SPECIFICATION

---

### Certifications

Interroll Drum Motors can be offered certified and approved according to UL 1004 for the North American market and cUL for the Canadian market.

Interroll Drum Motors for use in the food processing industry are EHEDG-compliant. The materials meet the requirements of the FDA, EC 1935/2004. Cleaning specialist Diversey has certified compatibility with the products Acifoam VF10, Easyfoam VF32, Divosan QC VT50, HD Plusfoam VF1, which are used for typical cleaning and disinfecting procedures of Interroll drum motors.







The Interroll Competence Center in Baal (near Düsseldorf) concentrates on drum motors that are employed as drive solutions in belt conveyors in food processing and other systems of internal logistics as well as various branches of industry. In this product sector, the company is responsible within the global Interroll Group for all technical concerns ranging from development and application engineering to production and support for local Interroll companies. The production area also includes the Coating Center for rubber-coated drum motors, which are intended for the hygienic production lines of the food industry.

Visit [www.interroll.com](http://www.interroll.com) to find your local contact person.  
Interroll Trommelmotoren GmbH  
Opelstr. 3 | 41836 Hückelhoven/Baal |  
Germany Tel.: +49 (0)2433 44610

## LEGAL NOTICES

### Contents

We strive for the information presented to be correct, up to date and complete. We have carefully developed the contents of this document. Nevertheless, errors and changes are expressly subject to change.

### Copyright/intellectual property right

Text, images, graphics and the like, as well as their arrangement, are protected by copyright and other protective legislation. Reproduction, modification, transfer or publication of any part or the entire content of this document in any form is prohibited. This document is intended exclusively for informational purposes and for intended use and does not authorize replication of the corresponding products. All identification symbols used in this document (protected trademarks, such as logos and commercial designations) are the property of Interroll AG or their respective owners and may not be used, copied or disseminated without prior written permission.

---

### **About Interroll**

The Interroll Group is a globally leading provider of solutions for material handling. The company was founded in 1959 and has been listed on the SIX Swiss Exchange since 1997. Interroll supplies system integrators and machine builders with a broad product range of platform-based products and services in the categories "Rollers" (conveyor rollers), "Drives" (motors and drives for conveyor systems), "Conveyors & Sorters" as well as "Pallet & Carton Flow" (flow storage systems). Solutions from Interroll are used by express and postal services, in e-commerce, in airports and in the areas of food & beverage, fashion, automotive and other industries. The company counts leading brands, such as Amazon, Bosch, Coca-Cola, DHL, Nestlé, Procter & Gamble, Siemens, Walmart, or Zalando, among its users. With its headquarters in Switzerland, Interroll features a worldwide network of 34 companies with roughly 2,300 employees (2020).

[interroll.com](https://www.interroll.com)

INSPIRED BY  
EFFICIENCY