

Operating manual

Interroll DriveControl

DriveControl 20 NPN



**UK
CA**

Manufacturer details

INTERROLL(Suzhou) Co. LTD.
NO. 16 HuiPu Road
Suzhou Industrial Park
Jiangsu Province, P.R.China
Zip code:215126

www.interroll.com

Content

We strive for the accuracy, timeliness and completeness of the information and have carefully prepared the contents in this document. Regardless of this, errors and changes are expressly reserved.

Copyright/industrial property rights

Any texts, images, graphics and the like, as well as their arrangement, are subject to protection under copyright and other laws of protection. The reproduction, modification, transmission or publication of any part of this document or of the entire document in any form is prohibited.

The document serves the exclusive purposes of information and of operation in accordance with the regulations and does not justify any counterfeiting of the products concerned.

All signs contained in this document (protected marks, such as logos and trade names) are the property of Interroll Holding AG, CH or of third parties and must not be used, copied or distributed without prior written consent.

Online version - only suitable for color printing!

Contents

1	About this document	7
1.1	Information about this operating manual	7
1.2	Warning notices in this document	8
1.3	Symbols	9
2	Safety-related information	10
2.1	State of the art	10
2.2	Proper use	10
2.3	Improper use	10
2.4	Qualification of personnel	11
2.5	Dangers	12
	Injury to persons	12
	Electricity	12
	Work environment	12
	Faults in operation	12
	Maintenance	12
	Unintentional start-up	12
2.6	Interface to other devices	12
2.7	Operating modes/operating phases	13
	Standard operation	13
	Special operation	13
2.8	Applicable documentation	13
3	Product information	14
3.1	Product description	14
	Energy recovery/overvoltage protection	14
	Overload protection	14
	Blocking time for signal changes	14
3.2	Setup	15
3.3	Scope of delivery	15
3.4	Technical specifications for DriveControl	16
3.5	DIP switches	17
3.6	Dimensions	17
4	Transport and storage	18
4.1	Transport	18
4.2	Storage	18

Contents

5	Assembly and installation	19
5.1	Warning notices for installation	19
5.2	Assembling the DriveControl	19
5.3	Warning notices for electrical installation	20
5.4	Electrical installation	21
	Connecting the power supply	21
	Inputs and outputs	22
5.5	Circuit diagrams	24
	Basic circuitry of DriveControl 20 NPN	24
	Minimum circuitry for DriveControl 20 NPN	25
	Connecting multiple error signals to one PLC	26
6	Start-up and operation	27
6.1	Start-up	27
	Check before the initial start-up	27
6.2	Configuration options	27
	Setting the speed	27
	Speed preselection via DIP switch	28
	Speed preselection via digital inputs	30
	Accelerating when using the DIP switch RAMP for the acceleration and deceleration ramp of the DriveControl	31
7	Maintenance and cleaning	32
7.1	Maintenance	32
	Checking the DriveControl	32
	Replacing the DriveControl	32
7.2	Cleaning	32
8	Assistance in the event of faults	33
8.1	Troubleshooting	33
8.2	Understanding the LEDs	34

9	Decommissioning and disposal	35
9.1	Decommissioning	35
9.2	Disposal	35
10	Appendix	36
10.1	Electrical data of the connections for DriveControl	36
	Connection for inputs/outputs	36
	RollerDrive connection	38
10.2	Translation of the original Declaration of Conformity	40
10.3	UKCA Declaration of Conformity	41



1 About this document

1.1 Information about this operating manual

This operating manual covers the following Interroll DriveControl models

- DriveControl 20 NPN

Throughout this manual, the term "control system" is used as an alternative for referring to these models.

The operating manual is a component of the product and contains important advice and information regarding the different operating phases of the DriveControl. It describes the DriveControl at the time of shipping from Interroll.

The currently applicable version of this operating manual can be found online at:

www.interroll.com

All the information and advice in this operating manual has been compiled with respect to applicable standards and regulations as well as the current state of the art.

- To ensure safe and faultless operation and to fulfil any warranty claims that may apply, read this operating manual first and observe its instructions.
- Keep this operating manual within close reach of the DriveControl.
- Pass this operating manual onto every subsequent owner or user.



The manufacturer assumes no liability for damage and malfunctions that occur as a result of non-compliance with this operating manual.



Should you still have any unanswered questions after reading this operating manual, please contact Interroll customer service. Contact details for your region can be found online at www.interroll.com

Please direct any comments and suggestions regarding our operating manuals to manuals@interroll.com

About this document

1.2 Warning notices in this document

Warning notices are provided in the context in which danger can occur and describe the nature of the danger in question. They are structured according to the following examples:



SIGNAL WORD

Type and source of hazard

Consequence(s) in the event of non-compliance

➤ Measure(s) for avoiding hazard

Signal words indicate the type and severity of the consequences if measures to avoid the hazard are not observed.



DANGER

Denotes an imminent hazard.

If measures to avoid the hazard are not observed, death or severe injury will occur.

➤ Preventive measures



WARNING

Denotes a potentially hazardous situation.

If measures to avoid the hazard are not observed, death or severe injury may occur.

➤ Preventive measures



CAUTION

Denotes the possibility of a hazardous situation.

If measures to avoid the hazard are not observed, minor or moderate injury may occur.

➤ Preventive measures

NOTE

Denotes a situation that can lead to material damage.

- Preventive measures
-

1.3 Symbols



This symbol indicates useful and important information.

- ✓ This symbol indicates a requirement that must be fulfilled before carrying out assembly or repair work.



This symbol indicates general information relating to safety.

- This symbol indicates an action that needs to be performed.
- This symbol indicates a listed item.

Safety-related information

2 Safety-related information

2.1 State of the art

The Interroll DriveControl has been constructed with respect to applicable standards and the current state of the art and has been delivered in a condition that is safe to operate. Nevertheless, hazards can occur as a result of use.



Non-compliance with the instructions in this operating manual can result in life-threatening injuries.

In addition, the applicable local accident prevention regulations for the area of application and general safety regulations must be adhered to.

2.2 Proper use

The DriveControl may only be used in an industrial environment for industrial purposes within the stipulated performance limits that are given in the technical specifications.

It controls an Interroll RollerDrive and must be integrated into a conveyor unit or conveyor system before commissioning.

2.3 Improper use

Any use that goes beyond the proper use is considered improper, unless this has been authorised by Interroll Engineering GmbH where applicable.

The equipment must not be installed in areas in which substances could form explosive atmospheres/dust atmospheres or for application in the medical/pharmaceutical sector.

It is considered improper use to install the equipment in exposed spaces that are open to potentially adverse weather conditions, or areas in which the technology would suffer from the prevailing climactic conditions and could potentially malfunction as a result.

The DriveControl is not intended for use by private end users. The equipment must not be used in a residential environment without further examination and without the use of EMC protective measures that have been adapted accordingly.

It must not be used as a safety-relevant component or for performing safety-relevant functions.

2.4 Qualification of personnel

Non-qualified personnel are unable to identify risks and are therefore exposed to higher levels of danger.

- Only qualified personnel may be assigned with the tasks outlined in this operating manual.
- The operating company is responsible for ensuring that personal adhere to the locally valid rules and regulations for working in a safe and risk-aware manner.

This operating manual is intended for the following target audiences:

Operators

Operators are trained in how to operate and clean the Interroll DriveControl unit and follow the safety regulations.

Service engineers

The service engineers have a specialist technical education or have successfully completed a training course from the manufacturer. They carry out repair and maintenance work.

Qualified electricians

Qualified electricians have a specialist technical education. Moreover, due to their knowledge and experience as well as knowledge of applicable regulations, they are able to carry out work on electrical equipment in an appropriate manner. They are able to identify hazards independently and prevent electrical damage to persons and property.

All work on electrical equipment must generally only be performed by a qualified electrician.

Safety-related information

2.5 Dangers



Here, you will find information about the different types of dangers or damage that can occur in connection with the operation of the DriveControl.

Injury to persons

- Maintenance, installation and repair work on the unit must only be carried out by authorised technical personnel in compliance with the applicable provisions.
- Before switching on the DriveControl, ensure that no unauthorised personnel are situated in the vicinity of the conveyor/conveying system.

Electricity

- Installation and repair work must only be carried out when the system has been disconnected from the power supply. Switch off the power to the DriveControl and ensure that it cannot be unintentionally switched on again.

Work environment

- Remove any materials and objects that are not required from the working area.

Faults in operation

- Regularly check the DriveControl for visible damage.
- If smoke develops, immediately switch off the power to the DriveControl and ensure that it cannot be unintentionally switched on again.
- Immediately contact specialist personnel to determine the cause of the malfunction.

Maintenance

- Since the product in question requires no maintenance, it is sufficient to simply examine the DriveControl for visible damage on a regular basis.
- Never open up the DriveControl.

Unintentional start-up

- Ensure that the connected RollerDrive/motors cannot start up unintentionally, particularly during assembly and maintenance work or in the event of a fault.

2.6 Interface to other devices

The integration of the DriveControl into a conveyor system can create additional potential hazards. Such potential hazards are not covered by this operating manual and must be analysed during the development, installation and commissioning of the conveyor system as a whole.

- Following the integration of the DriveControl into a conveyor system, the entire system must be checked for any new potential hazards that may be present before the conveyor is switched on.

2.7 Operating modes/operating phases

Standard operation

Operation in the installed condition at the end customer as a component in a conveyor in an overall system.

Special operation

Special operation encompasses all operating modes/operating phases that are necessary to guarantee and maintain safe standard operation.

Special operating mode	Comments
Transport/storage	-
Assembly/commissioning	In de-energised state
Cleaning	In de-energised state
Maintenance/repair	In de-energised state
Fault location	-
Troubleshooting	In de-energised state
Decommissioning	In de-energised state
Disposal	-

2.8 Applicable documentation

In order to ensure proper use of the DriveControl, additional operating manuals/documentation relating to the following must be consulted:

- Power supply unit
- RollerDrive
- Description of the conveyor system/unit



Also ensure that you adhere to the information given in the operating manuals of the connected devices.

Product-specific data can be read out via the Interroll Product App and the QR code on the nameplate. The Interroll Product App is available in all well-known app stores:



Product information

3 Product information

3.1 Product description

The DriveControl is a control system for conveyor systems that regulates the speed and rotational direction of an Interroll RollerDrive.

Control system	RollerDrive to be used
DriveControl 20 NPN	EC 310, EC 5000 AI 24 V DC (20 W and 35 W)

Energy recovery/overvoltage protection

If the RollerDrive is stopped or the speed is abruptly reduced, the kinetic energy of the conveyed material in the RollerDrive is converted into electrical energy, akin to a generator. This energy is fed back into the system, where it can be used by other RollerDrive units.

If more energy is fed back than can be used, the excess energy is converted into heat via a brake chopper in the DriveControl. The brake chopper becomes active when the voltage increases to over 26.5 V. This prevents excessively high voltages within the system.

Overload protection

The brake chopper resistance is monitored in terms of temperature. If the brake chopper resistance is frequently activated due to certain application properties (e.g. high weight of material to be conveyed or high conveyor speed), the DriveControl will be switched off whenever it gets too hot (an internal temperature of approx. 90 °C). Whenever the temperature protection is active, this will be indicated via the LEDs and a start signal will no longer be sent to the RollerDrive. Once the DriveControl has cooled down, the RollerDrive will automatically switch on again whenever a start signal is issued.



The DriveControl will cool down faster if it is mounted on a level surface, ideally one made of metal.

NOTE

Irreparable damage to the DriveControl through overheating

- Do not carry out a power reset while the overload protection is active, as this causes faults to reoccur.

Blocking time for signal changes

The following signals are protected by the firmware to guarantee their functionality in the event of bouncing and instability. This means that once a signal has been changed, the next signal change will only be processed after 20 ms.

- DIP switch SPEED A, SPEED B, SPEED C, SPEED D, DIR, RAMP
- Inputs for RollerDrive ERROR, SPEED A, SPEED B, SPEED C, DIR

3.2 Setup

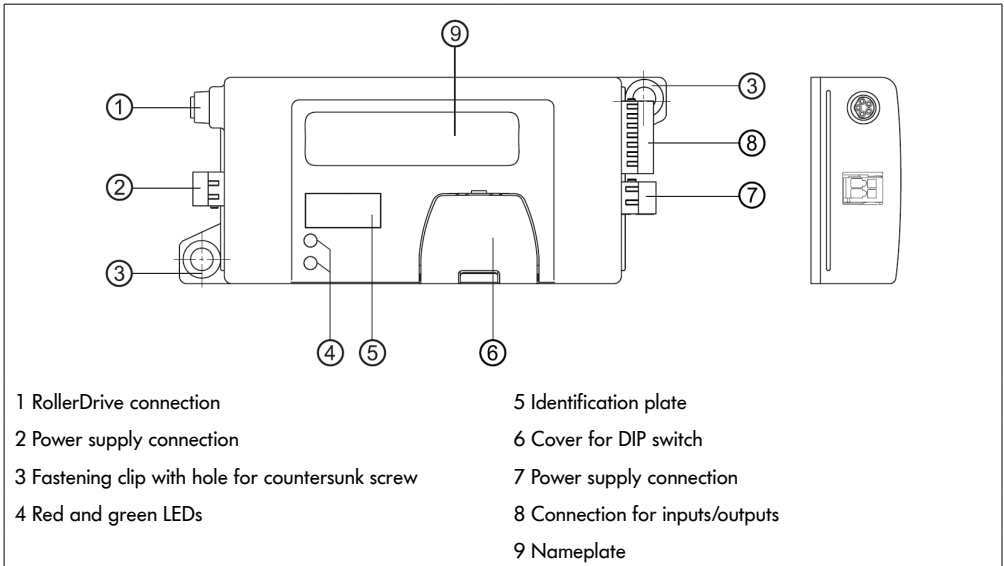

3.3 Scope of delivery

- DriveControl
- Connector for power supply (WAGO 734-102/xxx-xxx)
- Connector for inputs/outputs (WAGO 733-107/xxx-xxx)
- Auxiliary tool for connector for power supply (black)
- Auxiliary tool for connector for inputs/outputs (yellow)

Product information

3.4 Technical specifications for DriveControl

DriveControl 20 NPN	
Rated voltage	24 V DC, protected extra-low voltage (PELV)
Voltage range	19 to 26 V DC
Current consumption	With RollerDrive: Up to 5 A Without RollerDrive: 0.1 A
Protection rate	IP20
Cooling system	Convection
Weight	500 g (incl. base plate)
Ambient temperature in operation	0 °C to +40 °C
Relative humidity in operation	93% at +40 °C, 14 days, non-condensating
Ambient temperature during transport and storage	-40 °C to +85 °C
Relative humidity during transport and storage	5–95%, condensation not permitted
Altitude of installation site	Max. 1000 m In principle, it is possible to install the equipment at altitudes higher than 1000 m. However, this may reduce the performance values.

3.5 DIP switches

The DIP switches can be used to select the speed and the direction of the conveyor.

In the as-delivered condition, the DIP switches DIR and RAMP are set to OFF and the DIP switches SPEED A, B, C, and D are set to ON.

DIP switch	ON	OFF
DIR	RollerDrive will rotate clockwise (as seen from the cable side)*	RollerDrive will rotate anti-clockwise (as seen from the cable side)*
SPEED A, B, C, D	For speed settings, see „Speed preselection via DIP switch“ on page 28	
RAMP	Acceleration and deceleration ramp active	

*The rotational direction is reversed if the input DIR is connected.

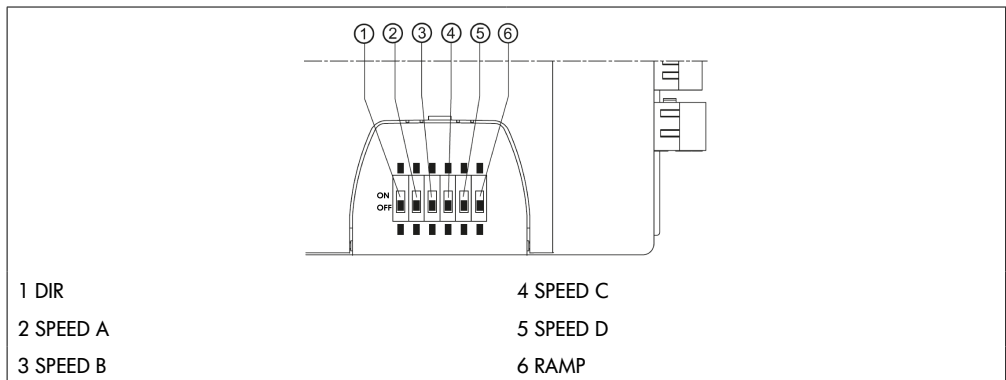

3.6 Dimensions

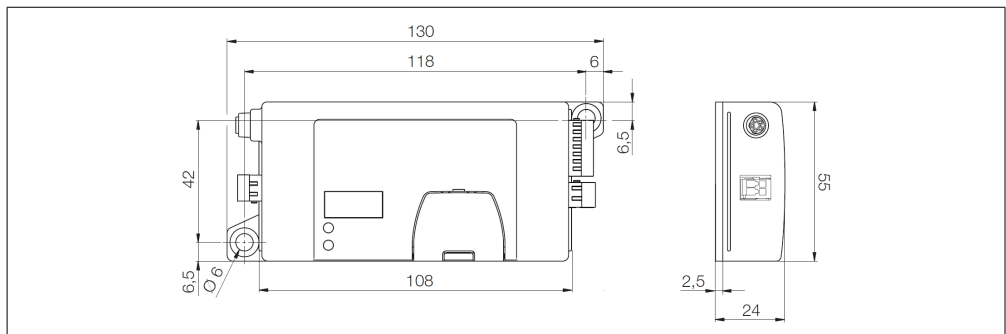

Transport and storage

4 Transport and storage

4.1 Transport



CAUTION

Risk of injury from improper transport.

- Transport operations must only be carried out by authorised, qualified personnel.
-

Please note the following:

- Do not stack pallets on top of one another.
- Prior to transport, check whether the DriveControl is correctly attached.
- Avoid heavy impacts during transport.
- Check each DriveControl after transport for any visible damage.
- If any damage has been identified, photograph the damaged parts.
- In the event that damage has been incurred during transport, inform the shipping agent or Interroll immediately to ensure that you do not lose any potential damage claims.
- Do not expose the DriveControl to any strong fluctuations in temperature, since this can lead to condensation forming.

4.2 Storage



CAUTION

Risk of injury due to improper storage.

- Ensure that the DriveControl is stored safely.
-

Please note the following:

- Do not stack pallets on top of one another.
- Check each DriveControl after storage for any visible damage.

5 Assembly and installation

5.1 Warning notices for installation

NOTE

An improper approach to installing the DriveControl can lead to material damage or reduce the service life of the DriveControl.

- To preserve the interior of the DriveControl, do not allow the DriveControl to fall or for it to be used in an improper fashion.
 - Check each DriveControl before assembly for any visible damage.
 - Ensure that the DriveControl is not tensioned during the assembly process (no bending or torsional load).
 - Do not drill any additional mount holes into the housing and do not enlarge any existing holes.
 - Ensure that the permitted operating temperature is under no circumstances exceeded as a result of external heat sources.
-

5.2 Assembling the DriveControl

- Look for level surfaces that are suitable for mounting the DriveControl on.
- Use the DriveControl as a template and mark the middle of the two installation holes. For the distance between the installation holes, see „Dimensions“ on page 17.
- Drill two installation holes with diameters of 5.6–6 mm on the markings.
- Screw on the DriveControl.
- Make sure the housing has not been distorted.

Assembly and installation

5.3 Warning notices for electrical installation



CAUTION

Risk of injury when working on electrical equipment.

- Electrical installation work must only be carried out by a qualified electrician.
- Before installing, removing or connecting the DriveControl, switch off the power to the conveyor system and ensure that it cannot be unintentionally switched on again.
- Set all the power supplies used to the same ground potential in order to avoid compensating currents via the DriveControl.
- Ensure all components are earthed correctly. Improper earthing can lead to a build-up of static charge, which can result in a fault or premature failure of the DriveControl.
- Ensure that suitable switching devices and protective systems are in place that will allow the equipment to be operated safely.
- Only switch on the operating voltages when all cables are connected.

NOTE

Improper electrical installation can result in damage to the DriveControl.

- Observe national regulations for electrical installation.
- Only operate the DriveControl with a protective extra-low voltage (PELV) of 24 V.
- Never operate the DriveControl with an alternating voltage.
- Ensure that the polarity of the power supply is correct.
- Ensure that the existing electrical installation has no disruptive influence on the DriveControl.
- Only use cables that are adequately dimensioned for the specific operating conditions.
- Ensure that the calculations for the drop in voltage in the cables are taken into account.
- Observe regulations for laying cables.
- Do not expose the connectors to excessively high tensile or pressure loads. If the connector cable is bent, this can damage the cable insulation and cause the DriveControl to fail.

5.4 Electrical installation

Connecting the power supply



The DriveControl is fitted with an internal, non-replaceable fuse that serves exclusively to protect the device. The protection of the supply cables must be guaranteed by the operator.

Required cables:

Connection	Conductor cross-section
Inputs/outputs	Flexible wire: 0.08 to 0.5 mm ²
	Flexible wire with ferrule terminal: 0.25 to 0.34 mm ²
	Stripping length: 5 to 6 mm
Power supply	Flexible wire: H05 (07) V-K 1.5 mm ²
	Ferrule terminal optional
	Stripping length: 6 to 7 mm

- Prepare wire ends in accordance with the recommendations of the contact manufacturer.
- Insert the cables for the inputs/outputs into the connector using the yellow auxiliary tool (see „Inputs and outputs“ on page 22).
- Insert the power supply cables into the connector using the black auxiliary tool.
- Insert the connector into the DriveControl.
- If necessary, adjust the DIP switch in accordance with the requirements (see „Configuration options“ on page 27).
- Insert the RollerDrive connector so that the "RD" label on the DriveControl is visible and the label on the connector faces the rear (and is therefore not visible).

Assembly and installation

Inputs and outputs

RollerDrive connection – 8 mm snap-in, five-pin, contact assignment as per DIN EN 61076-2

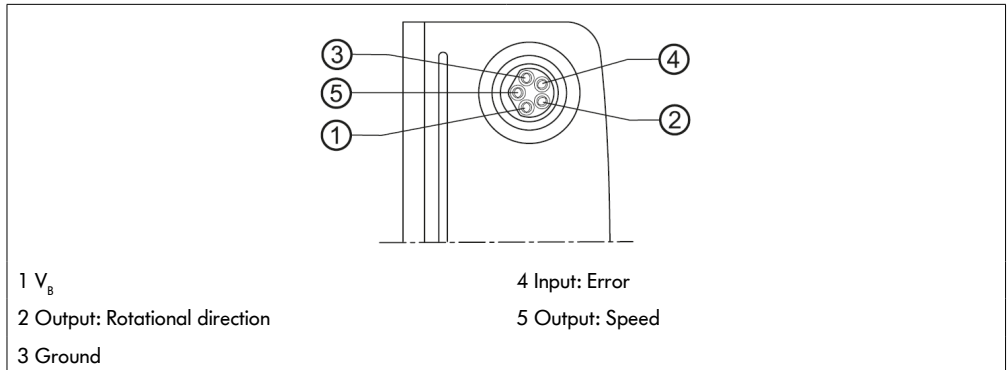

Power supply connection



The power supply connection features a double-sided design, meaning the most favourable side (in terms of installation) can be used to connect the power supply. Both connections are directly internally linked with one another. The power supply can be fed through a DriveControl, allowing a maximum of two DriveControl units to be connected in succession.

DriveControl 20 NPN

V_B	+24 V DC
-------	----------

Connection for inputs/outputs

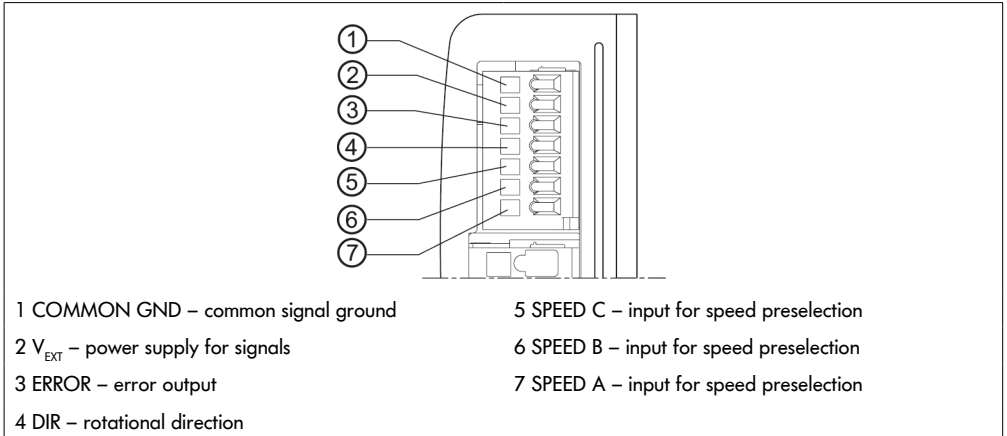

V_{EXT} typically corresponds to +24 V DC.

Assembly and installation

5.5 Circuit diagrams

The control inputs SPEED A, SPEED B, SPEED C, DIR and the output signal ERROR are completely galvanically separated from the power supply V_B by means of optical couplers.

The control inputs and the output signal are supplied via the external voltage V_{EXT} . The common ground connection for the signals SPEED A, SPEED B, SPEED C, DIR and ERROR is COMMON GND.

Basic circuitry of DriveControl 20 NPN

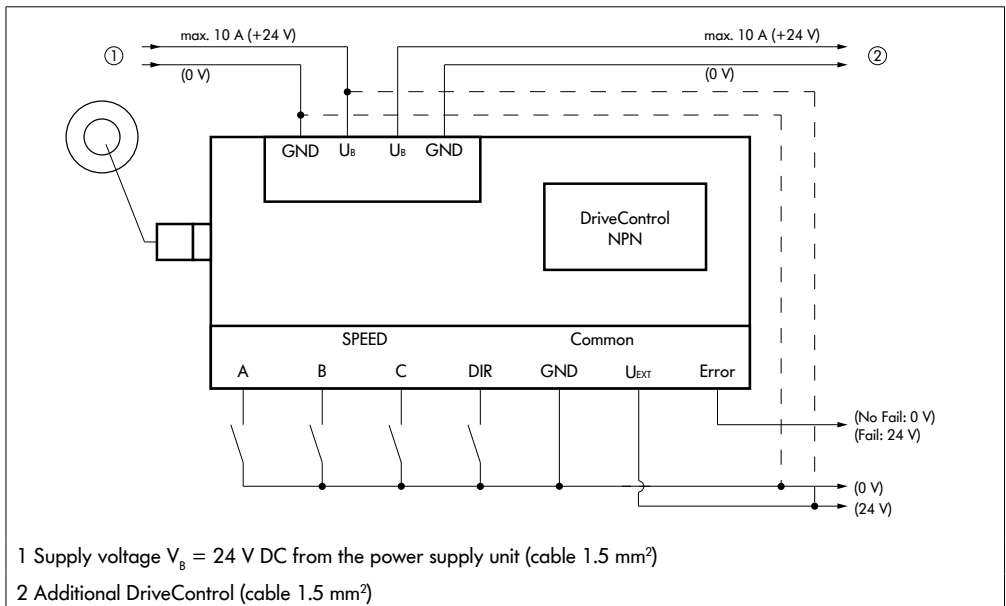

The dashed lines are only used when no galvanic separation is required between the control signals and the supply voltage.

In this case, the power for the control signals is supplied by the supply voltage V_B .

Minimum circuitry for DriveControl 20 NPN

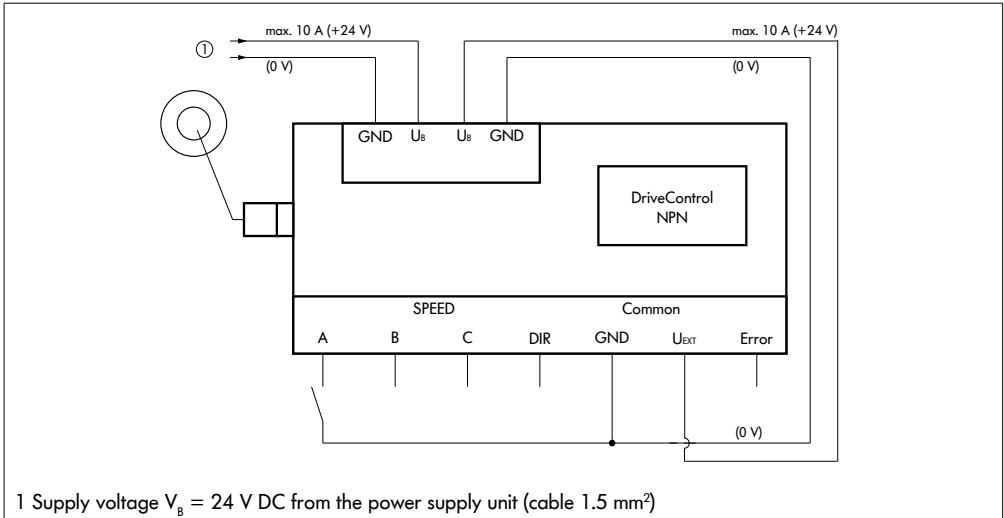

This circuitry enables the specification of the target values for rotational speed and rotational direction via the internal DIP switch.

The error signal is not used; errors are only indicated via the red LED.

Starting and stopping can be controlled by changing the level on the SPEED A connection.

NOTE

The DriveControl and RollerDrive must not be controlled by switching the power supply on or off. They must only be controlled via the start signal (SPEED A, B, C).

Assembly and installation

Connecting multiple error signals to one PLC

In order to be able to interpret the error signal, the input V_{EXT} must be supplied with a voltage of 24 V DC.

- Connect the ERROR output of the preceding DriveControl with the input Common GND of the subsequent DriveControl.

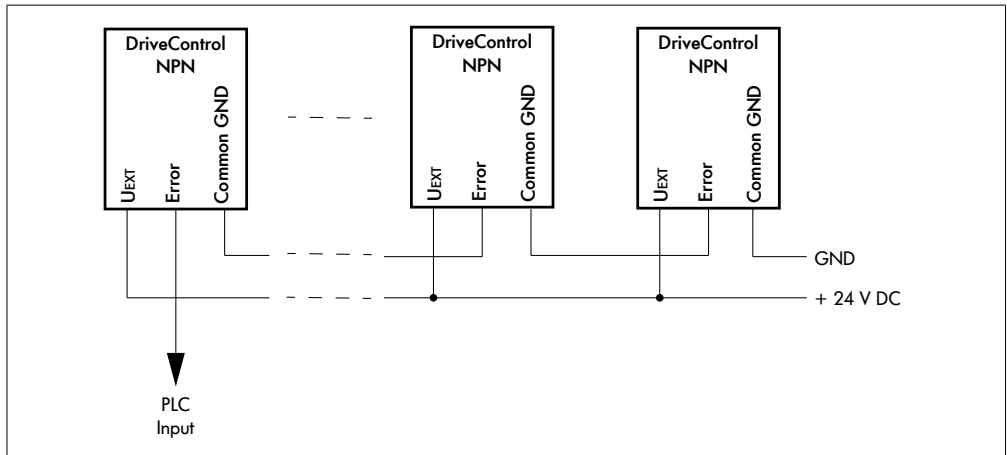

When the operating voltage is switched off, the ERROR output will switch to the "error" state. This guarantees a correct error message even when the error signal has been linked from multiple DriveControl units and the operating voltage of a DriveControl unit is switched off, or a cable error has occurred (detached contact, cable break).

When the operating voltage is switched on, the error signal is issued until the internal microcontroller has assumed control. If no error is present, the error signal is terminated approx. 400 ms after the operating voltage has been switched on.

NOTE

Incorrect polarity will irreparably damage the DriveControl.

Ensure that the polarity of the supply voltage V_{EXT} is correct.

6 Start-up and operation

6.1 Start-up

Check before the initial start-up

- Ensure that the base plate of the DriveControl has been correctly attached to the profile and that all screws have been properly tightened.
- Ensure that no additional hazards are formed through the interfaces to other components.
- Ensure that the wiring conforms to the specifications and legal provisions.
- Check all protective equipment.
- Ensure that no persons are in the hazardous areas by the conveyor system.

6.2 Configuration options

Setting the speed

The speed of the RollerDrive can be adjusted via the DriveControl in two ways:

- Internally, via a DIP switch. This method is given priority and allows for finer increments.
- Externally, via three digital inputs in eight levels (speed changes are also possible during operation, whereby a quasi ramp function can be implemented via corresponding circuitry of a PLC).

This speed setting is converted into an analogue control voltage by the DriveControl, which is then interpreted by the RollerDrive as a target value setting. This target value setting is independent of the RollerDrive gears and their diameters.

The acceleration and deceleration characteristics of the RollerDrive are determined by their own moment of inertia, the gears used, the conveyor speed, the moment of inertia of the connected conveyor rollers, the selected operating medium and the transported mass.



The varying rated speeds and gear stages of the RollerDrive units used will result in different speeds.

- RollerDrive EC310 = rated speed 6000 rpm
- RollerDrive EC5000 AI = rated speed 6900 rpm

Start-up and operation

Speed preselection via DIP switch

Position of the DIP switch				Speed of the gear ratio for RollerDrive EC310									
SPEED on the DriveControl				[m/s]									
A	B	C	D	9:1	12:1	16:1	20:1	24:1	36:1	48:1	64:1	96:1	
on	on	on	on	1,75	1,31	0,98	0,79	0,65	0,44	0,33	0,25	0,16	
on	on	on	off	1,63	1,22	0,92	0,73	0,61	0,41	0,31	0,23	0,15	
on	on	off	on	1,51	1,13	0,85	0,68	0,57	0,38	0,28	0,21	0,14	
on	on	off	off	1,39	1,04	0,78	0,63	0,52	0,35	0,26	0,20	0,13	
on	off	on	on	1,27	0,95	0,72	0,57	0,48	0,32	0,24	0,18	0,12	
on	off	on	off	1,15	0,86	0,65	0,52	0,43	0,29	0,22	0,16	0,11	
on	off	off	on	1,03	0,78	0,58	0,47	0,39	0,26	0,19	0,15	0,10	
on	off	off	off	0,92	0,69	0,52	0,41	0,34	0,23	0,17	0,13	0,09	
off	on	on	on	0,80	0,60	0,45	0,36	0,30	0,20	0,15	0,11	0,07	
off	on	on	off	0,68	0,51	0,38	0,31	0,25	0,17	0,13	0,10	0,06	
off	on	off	on	0,56	0,42	0,32	0,25	0,21	0,14	0,11	0,08	0,05	
off	on	off	off	0,44	0,33	0,25	0,20	0,17	0,11	0,08	0,06	0,04	
off	off	on	on	0,32	0,24	0,18	0,15	0,12	0,08	0,06	0,05	0,03	
off	off	on	off	0,21	0,15	0,12	0,09	0,08	0,05	0,04	0,03	0,02	
off	off	off	on	0,09 ¹⁾	0,07 ¹⁾	0,05 ¹⁾	0,04 ¹⁾	0,03 ¹⁾	0,02 ¹⁾	0,02 ¹⁾	0,01 ¹⁾	0,01 ¹⁾	
off	off	off	off	Corresponding to the signals on the inputs SPEED A, B, C									

Nominal values at an ambient temperature of 20 °C

¹⁾ Due to tolerances and / or voltage drop on cables, it is possible that the RollerDrive does not turn with this setting. In this case, the next higher setting and thus speed or a control with free speed selection (MultiControl) must be selected.

Start-up and operation

Position of the DIP switch SPEED on the DriveControl				Speed of the gear ratio for RollerDrive EC5000 AI [m/s]									
A	B	C	D	9:1	13:1	18:1	21:1	30:1	42:1	49:1	78:1	108:1	
on	on	on	on	2,01	1,39	1,00	0,86	0,60	0,43	0,37	0,23	0,17	
on	on	on	off	1,87	1,29	0,93	0,80	0,56	0,40	0,34	0,22	0,16	
on	on	off	on	1,73	1,20	0,87	0,74	0,52	0,37	0,32	0,20	0,14	
on	on	off	off	1,60	1,10	0,80	0,68	0,48	0,34	0,29	0,18	0,13	
on	off	on	on	1,46	1,01	0,73	0,63	0,44	0,31	0,27	0,17	0,12	
on	off	on	off	1,32	0,91	0,66	0,57	0,40	0,28	0,24	0,15	0,11	
on	off	off	on	1,18	0,82	0,59	0,51	0,36	0,25	0,22	0,14	0,10	
on	off	off	off	1,05	0,72	0,52	0,45	0,31	0,22	0,19	0,12	0,09	
off	on	on	on	0,91	0,63	0,46	0,39	0,27	0,20	0,17	0,11	0,08	
off	on	on	off	0,77	0,54	0,39	0,33	0,23	0,17	0,14	0,09	0,06	
off	on	off	on	0,64	0,44	0,32	0,27	0,19	0,14	0,12	0,07	0,05	
off	on	off	off	0,50	0,35	0,25	0,21	0,15	0,11	0,09	0,06	0,04	
off	off	on	on	0,36	0,25	0,18	0,15	0,11	0,08	0,07	0,04	0,03	
off	off	on	off	0,22	0,16	0,11	0,10	0,07	0,05	0,04	0,03	0,02	
off	off	off	on	0,09 ¹⁾	0,06 ¹⁾	0,04 ¹⁾	0,04 ¹⁾	0,03 ¹⁾	0,02 ¹⁾	0,02 ¹⁾	0,01 ¹⁾	0,01 ¹⁾	
off	off	off	off	Corresponding to the signals on the inputs SPEED A, B, C									

Nominal values at an ambient temperature of 20 °C

¹⁾ Due to tolerances and / or voltage drop on cables, it is possible that the RollerDrive does not turn with this setting. In this case, the next higher setting and thus speed or a control with free speed selection (MultiControl) must be selected.

Start-up and operation

Speed preselection via digital inputs

Requirement: All DIP switches must be set to OFF.

- Set the external inputs for SPEED A, B, C to a logic level of (H)igh or (L)ow in accordance with the table below, in order to start the RollerDrive at the desired speed.
- To adjust the speed, change the signals on the inputs SPEED A, B, C accordingly.
- To stop the RollerDrive, switch all the inputs SPEED A, B, C to a logic level of (L)ow.



The internal speed setting is given priority. If one or more of the internal DIP switches SPEED A, B, C, D are set to ON while the speed is specified externally, the RollerDrive will rotate at this internally set speed, independent of the signals from the external inputs. If all internal DIP switches SPEED A, B, C, D are set to OFF, the RollerDrive will once again rotate at the speed that is set through the external inputs.

Inputs SPEED on the DriveControl			Speed of the gear ratio for RollerDrive EC310 [m/s]									
A	B	C	9:1	12:1	16:1	20:1	24:1	36:1	48:1	64:1	96:1	
L	L	L	1,75	1,31	0,98	0,79	0,65	0,44	0,33	0,25	0,16	
L	L	H	1,47	1,10	0,82	0,66	0,55	0,37	0,27	0,21	0,14	
L	H	L	1,19	0,89	0,67	0,53	0,44	0,30	0,22	0,17	0,11	
L	H	H	0,91	0,68	0,51	0,41	0,34	0,23	0,17	0,13	0,08	
H	L	L	0,65	0,49	0,36	0,29	0,24	0,16	0,12	0,09	0,06	
H	L	H	0,37	0,28	0,21	0,17	0,14	0,09	0,07	0,05	0,03	
H	H	L	0,09 ¹⁾	0,07 ¹⁾	0,05 ¹⁾	0,04 ¹⁾	0,03 ¹⁾	0,02 ¹⁾	0,02 ¹⁾	0,01 ¹⁾	0,01 ¹⁾	
H	H	H	0	0	0	0	0	0	0	0	0	

Nominal values at an ambient temperature of 20 °C

¹⁾ Due to tolerances and / or voltage drop on cables, it is possible that the RollerDrive does not turn with this setting. In this case, the next higher setting and thus speed or a control with free speed selection (MultiControl) must be selected.

Inputs SPEED on the DriveControl			Speed of the gear ratio for RollerDrive EC5000 AI								
A	B	C	[m/s]								
			9:1	13:1	18:1	21:1	30:1	42:1	49:1	78:1	108:1
L	L	L	2,01	1,39	1,00	0,86	0,60	0,43	0,37	0,23	0,17
L	L	H	1,68	1,17	0,84	0,72	0,50	0,36	0,31	0,19	0,14
L	H	L	1,36	0,94	0,68	0,58	0,41	0,29	0,25	0,16	0,11
L	H	H	1,03	0,72	0,52	0,44	0,31	0,22	0,19	0,12	0,09
H	L	L	0,74	0,51	0,37	0,32	0,22	0,16	0,14	0,08	0,06
H	L	H	0,41	0,28	0,21	0,18	0,12	0,09	0,08	0,05	0,03
H	H	L	0,09 ¹⁾	0,06 ¹⁾	0,04 ¹⁾	0,04 ¹⁾	0,03 ¹⁾	0,02 ¹⁾	0,02 ¹⁾	0,01 ¹⁾	0,01 ¹⁾
H	H	H	0	0	0	0	0	0	0	0	0

Nominal values at an ambient temperature of 20 °C

¹⁾ Due to tolerances and / or voltage drop on cables, it is possible that the RollerDrive does not turn with this setting. In this case, the next higher setting and thus speed or a control with free speed selection (MultiControl) must be selected.

Accelerating when using the DIP switch RAMP for the acceleration and deceleration ramp of the DriveControl

Position of the RAMP DIP switch	
ON	OFF
Acceleration and deceleration ramp of $t = 0.39$ seconds switched on. The time relates to the maximum speed. For lower speed preselection, the ramps diminish proportionally.	RollerDrive accelerates and decelerates as quickly as possible depending on the application.

Maintenance and cleaning

7 Maintenance and cleaning



CAUTION

Risk of injury from following incorrect procedure.

- Maintenance and repair work must only be carried out by authorised and trained (specialist) personnel.
- Maintenance and repair work must only be carried out when the system has been disconnected from the power supply. Switch off the power to the DriveControl and ensure that it cannot be unintentionally switched on again.
- Put up signs to indicate that maintenance or cleaning work is being carried out.

7.1 Maintenance

Checking the DriveControl

The DriveControl itself requires no maintenance. However, in order to prevent faults from occurring, the connections and fixings must be examined on a regular basis.

- In the course of regular inspection and maintenance work on the conveyor, ensure that the screws of the DriveControl are still tight, that the cables are still arranged correctly and that the corresponding connections are correctly attached.

Replacing the DriveControl

If a DriveControl is damaged or defective, it must be replaced.



Do not attempt to open the DriveControl.

- Install a new DriveControl (see „Decommissioning“ on page 35 and „Assembling the DriveControl“ on page 19).

7.2 Cleaning

Under humid conditions, dust and dirt can cause a short circuit. Therefore, ensure dirty environments are cleaned regularly to prevent short circuits that could damage the DriveControl.

NOTE

The DriveControl can be damaged if it is cleaned improperly.

- Never immerse the DriveControl in fluids.
- If necessary, vacuum any dust or dust that is present.
- To clean the DriveControl more thoroughly, disconnect it from the power supply, detach it and wipe it with a damp cloth.

8 Assistance in the event of faults

8.1 Troubleshooting

Fault	Possible cause	Remedy
DriveControl is not working or not working properly	No power supply	<ul style="list-style-type: none">➤ Ensure that the output voltage of the power supply is within the specified voltage range.➤ Check the connections and correct them if necessary.
	Incorrect position of the DIP switch	<ul style="list-style-type: none">➤ Check the position of the DIP switch and correct this if necessary (see „DIP switches“ on page 17).
DriveControl is defective or damaged	Internal fuse has been triggered or is defective	<ul style="list-style-type: none">➤ Replacing the DriveControl

The error signal is activated in the event of the following faults:

- Error on the RollerDrive
- RollerDrive not connected
- Voltage is outside the specified range (above or below)
- Chopper resistor overheated
- Initialisation phase

Assistance in the event of faults

8.2 Understanding the LEDs

The LEDs provide information about the operating state of the DriveControl and the RollerDrive.

Description	Parameter	LED ready	LED fault	RD speed	Error	Comments
Fuse faulty		Off	On	= 0		Repair not possible
RD ERROR high		On / F	FS	Unchanged	High	Determine whether the RollerDrive is faulty or needs to be replaced
RD not connected	Corresponds to RD ERROR high	On / F	FS	Unchanged	High	Connect the RollerDrive
Voltage is outside the specified range VBmin24, VBmax24	24 V	Off	FS	= 0	High	Self-terminating, once VB returns to the permitted range
Excessive temperature of chopper	$T \geq T_{Chmax}$	On	F	= 0	High	Chopper inactive, cooling of chopper to $T_{Ch} < T_{Chmax}$
Chopper overload	Chopper was active	Off	F	= 0	High	Self-terminating
RD rotates	No error	F	Off	$\neq 0$	Low	-
RD does not rotate	No error	On	Off	= 0	Low	No "start signal"
Initialisation phase		Off	On	= 0	High	

FS= LED flashes slowly (0.5 s on, 1.5 s off)

F = LED flashes fast (0.5 s on, 0.5 s off)

9 Decommissioning and disposal



CAUTION

Risk of injury from following incorrect procedure.

- Decommissioning must only be carried out by authorised, qualified personnel.
- Only decommission the DriveControl when the system has been disconnected from the power supply.
- Switch off the power to the DriveControl and ensure that it cannot be unintentionally switched on again.

9.1 Decommissioning

- Remove all cables from the DriveControl.
- Loosen the screws that have been used to attach the DriveControl to the conveyor frame.
- Remove the DriveControl from the conveyor frame.

9.2 Disposal



In principle, the operator is responsible for the professional and environmentally friendly disposal of the products.

The implementation of the WEEE Directive 2012/19/EU in national laws must be observed.

Appendix

10 Appendix

10.1 Electrical data of the connections for DriveControl

Connection for inputs/outputs

Input 24 V (pin 2)

Properties	Galvanically separated	
Voltage range	19 to 26 V DC	
Insulation strength	Max. 500 V _{eff}	1 min, 50 Hz
Reverse polarity protection	Max. 30 V DC	
Current consumption	Max. 100 mA	Must be guaranteed through external circuitry

Output ERROR (pin 3)

Properties	Galvanically separated, not permissible to feed in an external voltage	
Insulation strength	Max. 500 V _{eff}	1 min, 50 Hz
Logic level for fault	Max. 1 V DC	
Output current for fault	Max. 1 mA	
Logic level for no fault	10 to 26 V DC	
Output current for no fault	Max. 50 mA	Not short-circuit proof

Inputs SPEED A, SPEED B, SPEED C and DIR (pin 4–7)

Properties	Debounced, galvanically separated	
Reverse polarity protection	Max. 30 V DC	
Overvoltage protection	Max. 30 V DC	Permanent, free of harmonic waves
Insulation strength	Max. 500 V _{eff}	1 min, 50 Hz
Logic level, low	0 to 1 V DC	Logic level 0 = L = inactive
Input current, low	Max. 0.1 mA	
Logic level, high	19 to 26 V DC	Logic level 1 = H = active
Input current, high	2.5 to 4.5 mA	

Appendix

RollerDrive connection

Power supply (pin 1, 3)

Rated value	24 V DC	
Voltage range	19 to 26 V DC	
Residual ripple	Max. 600 mV _{pp}	
Rated current	2.3 A	
Starting current	Max. 5 A	Max. 250 ms > 2.3 A, Time-dependent current course, triangular-shaped, duty ratio ≤ 19%
Voltage feedback stability	Max. 35 V DC	Free of harmonic waves Max. 500 ms; after 500 ms, the reserve voltage must be ≤ 27 V, duty ratio max. 27%

Output: Rotational direction

Properties	Not galvanically separated, short-circuit proof, not permissible to feed in an external voltage	
Oversvoltage protection	Max. 30 V DC	
Anti-clockwise rotation	Max. 4 V	Logic level 0
Output current, low	Max. 1 mA	Load resistance = 57 kΩ
Clockwise rotation	Min. 7 V	Logic level 1
Output current, high	Max. 0.2 mA	For short circuit

Input: Error (pin 4)

Properties	Not galvanically separated	
Reverse polarity protection	Max. 30 V DC	
Max. voltage	30 V DC	
Logic level, low	Max. 8.5 V DC	@ 1.5 mA Logic level 0 = L = no error
Residual current, low	1.5 mA Max. 5 mA	
Logic level, high	12 to 30 V DC	Logic level 1 = H = error
Residual current, high	Max. 0.01 mA	

Output: Speed (pin 5)

Properties	Not galvanically separated	
Speed setting range for motor control voltage	2.3 to 10 V DC	RollerDrive rotates
Stop range	0 to 2 V DC	RollerDrive does not rotate
Accuracy of motor control voltage	5%	Motor control voltage between 2.3 and 10 V DC at 21 °C
Ripple of motor control voltage	250 mV _{pp}	50 Ω
Max. load for motor control current	0.16 to 2 mA	Input resistance for RollerDrive: 66 kΩ
Rate of change	4.5 to 5 V/ms	0–100% motor control voltage

Appendix

10.2 Translation of the original Declaration of Conformity

EU Declaration of conformity

EMC Directive 2014/30/EU

RoHS Directive 2011/65/EU

The manufacturer

INTERROLL(Suzhou) Co. LTD.
NO. 16 Huiipu Road
Suzhou Industrial Park
Jiangsu Province, P.R.China
Zip code:215126

hereby declares that the

- **Interroll DriveControl 20 NPN**

conforms to the applicable provisions and the associated CE marking in accordance with the aforementioned Directives.

List of the coordinated standards that have been applied:

EN 61000-6-2:2005/AC:2005
EN 61000-6-3:2007/A1:2011/AC:2012
EN IEC 63000:2018

Authorised for compiling technical documentation:

Interroll Software & Electronics GmbH, Im Südpark 183, 4030 Linz

10.3 UKCA Declaration of Conformity

Declaration of conformity

UK Electromagnetic Compatibility Regulations 2016

UK Restriction of the Use of Certain Hazardous Substances in
Electrical and Electronic Equipment Regulations 2012

The manufacturer

INTERROLL(Suzhou) Co. LTD.
NO. 16 Huiipu Road
Suzhou Industrial Park
Jiangsu Province, P.R.China
Zip code:215126

hereby declares that the

- **Interroll DriveControl 20 NPN**

**conforms to the applicable provisions and the associated UKCA marking
in accordance with the aforementioned Directives.**

Authorised for compiling technical documentation:
Interroll Software & Electronics GmbH, Im Südpark 183, 4030 Linz

INSPIRED BY EFFICIENCY

EN | 07/2022 | Version 2.0