

# GENERAL TECHNICAL INFORMATION

## PLATFORMS

### Platforms

Interroll Conveyor Roller Series are arranged into five so-called platforms. Each platform is characterized by a certain type of bearing and certain materials – the two key factors for the operation and application possibilities of the products.

The following applies within a platform:

- The bearings and materials for the bearing housing and seal are identical
- The size of the bearings may differ
- The versions are produced by the combination of shaft/tube dimensions and drive heads as well as the materials

#### Platform 1100

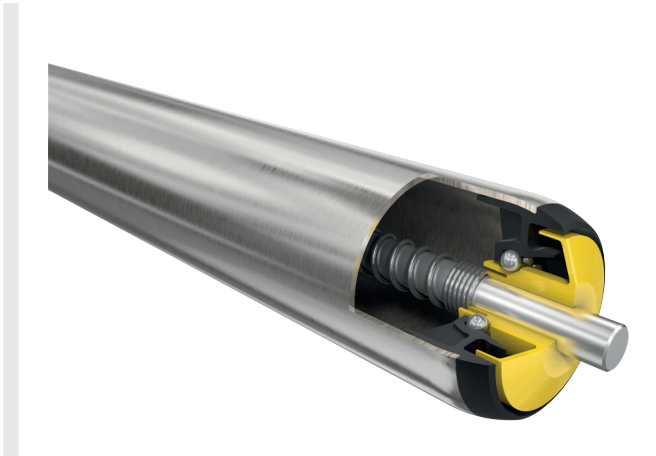

Associated roller series		Catalog page
Gravity conveyor roller	1100	page 30
Polymer conveyor wheel	2130	page 140
Polymer conveyor wheel	2370	page 146
Wheel track	BU40 with polymer wheels	page 168

#### Application

- For gravity applications
- Particularly smooth operation of conveyor rollers
- Stainless steel version suitable for moist areas
- For lightweight and medium-heavy materials to be conveyed
- Not suitable for drive conveyors

#### Properties

Platform 1100 provides for cost-effective solutions and is particularly suitable for gravity applications under normal ambient temperatures.

For information about properties and application areas of the polymers used, please refer to the chapter Material Specification Material Specification.

#### Bearings and materials

The bearing is made of polymer with balls made of uncoated steel or stainless steel. The outer ring and inner cone of the bearing are made of polypropylene. The bearings are lubricated with a food-safe grease.

#### Platform 1200



Associated roller series		Catalog page
Steel conveyor roller	1200	page 36
Steel conveyor wheel	2200	page 144
Wheel track	BU40 with steel rollers	page 168

#### Application

- For temperature ranges outside of the limits for polymer
- For lightweight and medium-heavy materials to be conveyed
- For driven and non-driven conveyors

#### Properties

Platform 1200 is specifically designed for use in extreme ambient temperatures. All versions are antistatic.

## Bearings and materials

The pressed steel bearing seats and internal rings of the ball bearing are hardened and galvanized zinc-plated. The shape of the ball bearing is designed specifically for conveyor rollers and tolerates greater deflection of the bearing than comparable precision ball bearings.

### Platform 1450

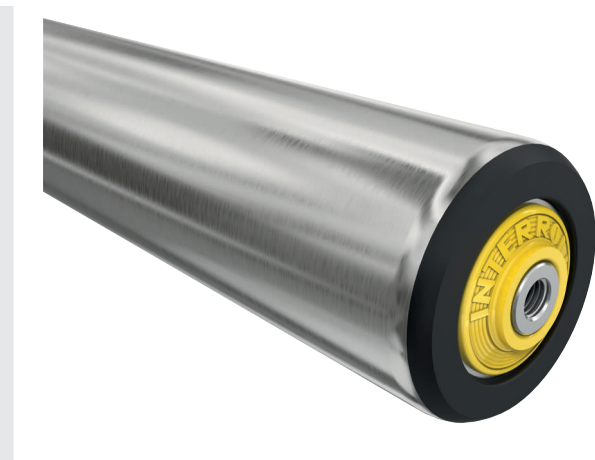

Associated roller series		Catalog page
Heavy-duty universal conveyor roller	1450	page 42
Heavy-duty conveyor roller	3950	page 130

## Application

- For particularly heavy-duty loads and heavy individual loads
- Suitable for extreme temperatures with steel bearing housings
- For driven and non-driven conveyors

## Properties

Platform 1450 is specifically designed for high loads caused by heavy individual weights. One version is available for deep freeze applications.

The drive elements made of technopolymers are designed to be twist-proof with a form-fit connection with the tube. The steel drive heads and flanges are all galvanized zinc-plated after being welded to the tube for optimum corrosion protection. All of the welds run right around the tube, not just in certain areas. For information about properties and application areas of the polymers used, please refer to the chapter Material Specification Material specification.

## Bearings and materials

The standard version bearings are precision ball bearings 6205 2RZ or 6204 2RZ. Depending on the series, the drive elements, such as sprockets or toothed belt drive heads, are made of fiberglass-reinforced polyamide and polyoxymethylene or steel. The bearing housing on the non-driven side and the seals are made of polyamide.

### Platform 1500



Associated roller series		Catalog page
Slide bearing conveyor roller	1500	page 48
Omnwheel	2500	page 148
Omnimat module	2800	page 154
Wheel track	Floway	page 166

## Application

- For wet and hygienic areas
- For lightweight and medium-heavy materials to be conveyed
- For driven and non-driven conveyors

## Properties

Platform 1500 is specifically designed for use in hygienic areas and in areas at risk of corrosion.

All of the bearing housings are sealed internally so that liquids or other substances cannot penetrate the rollers. The conveyor rollers can be cleaned with conventional detergents.

For information about properties and application areas of the polymers used, please refer to the chapter Material Specification Material specification.

# GENERAL TECHNICAL INFORMATION

## PLATFORMS

### Bearings and materials

The bearings are designed as slide bearings and are made of polymer (polyoxymethylene with the addition of polytetrafluorethylene (PTFE)) with a stainless steel shaft pin. The materials and surfaces of the bearing pair are aligned to each other so that the bearings can run dry without lubrication. The tubes are made of polymer or stainless steel. All of the materials are completely corrosion-proof.

### Platform 1700

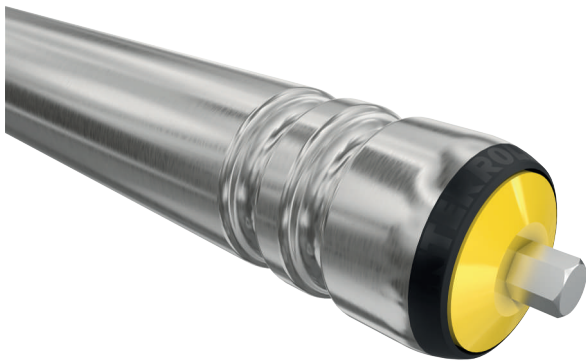

Associated roller series		Catalog page
Universal conveyor roller	1700 light	page 54
Universal conveyor roller	1700	page 58
Tapered universal conveyor roller	1700KXO	page 66
Universal conveyor roller	1700 heavy	page 72
Pressure roller	2600	page 150
Fixed drive conveyor roller	3500 light	page 76
Fixed drive conveyor roller	3500	page 80
Fixed drive curve roller	3500KXO light	page 92
Fixed drive curve roller	3500KXO	page 96
Fixed drive conveyor roller	3500 heavy	page 102
Friction conveyor roller, double friction conveyor roller	3800 light	page 108
Friction conveyor roller	3800	page 112
Double friction conveyor roller	3870	page 124
Roller track	BU50	page 174
Magnetic speed controller	MSC 50	page 136

Associated roller series		Catalog page
RollerDrive	EC5000	–

### Application

- For universal use
- For particularly quiet conveyance at high speeds
- For lightweight and medium-heavy materials to be conveyed
- For driven and non-driven conveyors

### Properties

Platform 1700 is designed for high loads at very low noise levels and provides the ultimate in flexibility with its different drive options. The bearing design comprising polyamide bearing housing, precision ball bearing and a polypropylene or polyamide seal produces an extremely quiet conveyor roller, which can simultaneously carry heavy loads. Bearing housings and belt drive heads are installed in the tubes in a form-fit way (flanging for steel tube and press-in edge for polymer tube). The unique feature about this platform 1700 is the tapered shaft-shuttle, which combines the benefits of a female threaded shaft and a spring-loaded shaft (cf. shaft-shuttle shaft design page 13).

For information about properties and application areas of the polymers used, please refer to the chapter Material Specification Material specification.

### Bearings and materials

Sealed DIN precision ball bearings 6002 2RZ, 689 2Z and 6003 2RZ are used. They are greased with a silicon-free lubricant and have a secure bearing housing in the base of the roller thanks to a snap-on edge. In addition, the ball bearing 6002 2RZ is oiled or available in a stainless steel design.

The integral polypropylene seal is fixed in the internal ring of the ball bearing and has three functions: Protection of the ball bearing against coarse dirt and splashing water, diameter compensation of shaft and internal ring as well as diverting axial forces into the ball bearing.

## Platform 5000



Associated roller series	Catalog page
Steel ball transfer unit 5000	page 156
Polymer ball transfer unit 5500	page 162

### Application

- For pushing, e.g. of steel or wooden plates
- For aligning medium-heavy and heavy materials

### Properties

The platform 5000 is designed for omni-directional pushing or aligning of medium-heavy and heavy materials. The series differ in the following features:

- Housing design
- Fastener
- Material of housing
- Material of support balls
- Material of main balls
- Load capacities

### Bearings and materials

The principle of the ball roller consists of several small support balls that support a larger main ball. The main ball can be made of polymer or steel, depending on the series. The housing can be of polyamide or steel.

## Bearings

Interroll utilizes different bearings, such as slide bearings or special ball bearings made of polypropylene with steel balls. However, the following section describes only the precision ball bearings used by Interroll.

Further information on the bearing assemblies (ball bearings with bearing housings and seals) is provided in the Platforms chapter (Platforms) and under Material Specification (Material specification).

All precision ball bearings used are designed as 2RZ, except for type 689. The steel sealing discs form a narrow sealing gap, but are non-contacting. They ensure an optimal startup of the roller. The steel-reinforced rubber sealing lips (NBR) lie against the inner ring under external pressure and thus provide an exceptional sealing quality comparable to the 2RS version. The oil-lubricated version is characterized by its easy start and exceptional easy-running properties.

Precision ball bearings in accordance with DIN 625 have the following properties:

- Series 689, 60 and 62 standard DIN grooved ball bearings
- Excellent load capacity and operational life
- Precision ball race
- Extremely temperature-resistant
- Low-noise operation
- With stainless steel design: manufactured throughout from corrosion-proof material

All precision ball bearings are specified by Interroll beyond the requirements of DIN 625 for optimum, durable and constant operation. Interroll specifies the bearing play, lubrication and sealing etc.

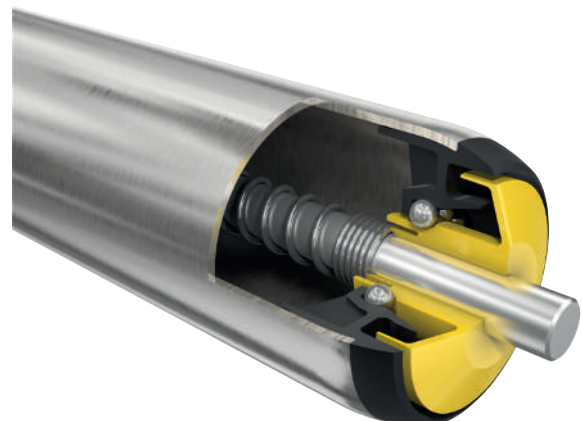

# GENERAL TECHNICAL INFORMATION

## SHAFTS

### Shafts

#### Shaft material

Interroll offers shafts made of three different materials or finishings:

- Uncoated steel
- Zinc-plated steel
- Stainless steel

All shafts are manufactured from cold-drawn steel. Interroll recommends to match the shaft material to the material of the side profile.

Zinc-plated shafts are cut from galvanized zinc-plated rod material, thus the front faces of the female threaded or spring-loaded shafts are always without zinc plating.

Male threaded shafts cannot be zinc-plated, otherwise they pose a risk of blocked threads due to the zinc layer. For this reason, Interroll recommends selecting either male threaded or flatted shafts in stainless steel to obtain adequate corrosion protection.

#### Manufacturing process

After the sawing process, the shafts are milled. Milling reduces deformations of the shaft ends or damages on the side profile during installation to a minimum. Furthermore, milling removes sharp burrs, thereby ruling out a risk of injuries. Hence, this creates not only safe, but also perfectly manageable rollers.

For threaded holes, the centering holes are drilled in a first step to ensure precisely centered threaded holes in the shaft.

#### Versions

##### Spring-loaded shaft

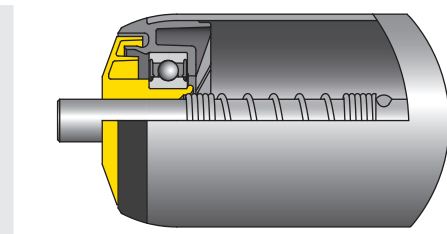

Spring-loaded shafts can be manufactured from round material or hex material.

- Simple shaft design
- Very fast and simple installation and removal
- Suitable crosslinks have to be provided between the side profiles to reinforce the conveyor.

- With driven rollers, play between the shaft and the mounting hole (inevitably due to oblique installation) will create noise, particularly when starting and stopping the turning motion (especially at hex shafts).
- Depending on the selection of material pairing (shaft/side profile) and dimensions (size of hole and spring-loaded shaft), it may lead to wear of the shaft (hexagon loses its edges) or the side profile.
- Shield for zinc-plated shaft material is not zinc-plated

##### Female threaded shaft

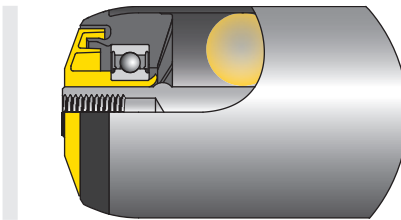

Female threaded shafts can be manufactured from round material or hex material.

- Lead to a very stable frame construction – generally, no use of crosslinks is required
- A firm connection causes a lot less noise than shafts that are not firmly screwed together.
- The roller shaft and side profile stabilize each other resulting in the conveyor rollers having a greater load capacity than loosely fitted rollers.
- Wear-free towards spring-loaded shafts due to firm connection in the side profile
- Medium-fast installation and removal
- Shield for zinc-plated shaft material not zinc-plated
- Safe discharge of static charges (anti-static design)

Interroll offers the following threads and thread depths:

Thread	Thread depths [mm]
M5	12
M6	15
M8	15
M10	20
M12	20, 25
M16	25

### Shaft with shaft-shuttle

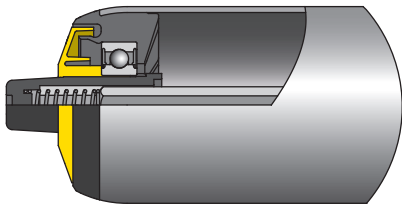

Shafts with shaft-shuttle are made of 8-mm hex material. Both ends are fitted with the shaft-shuttle made of polyamide. The conical shaft-shuttle reduces the hex surface towards the shaft end.

- Very fast and simple installation and removal
- Similar low noise level as female threaded shafts
- Wear-free towards spring-loaded shafts due to zero-clearance seating of the shaft free in the side profile (11 mm hex hole,  $+0.3/+0.8$  mm)
- Anti-static version
- Particularly suited for modernizing systems; side profiles that have been in use for a long time generally show high tolerances in the holes
- Evenly aligned, anti-rotation shuttles (positioning one side is sufficient)
- Both shaft ends can be pushed in
- Suitable crosslinks have to be provided between the side profiles to reinforce the conveyor
- No scratching of high-quality side profiles during installation and removal

### Male threaded shaft

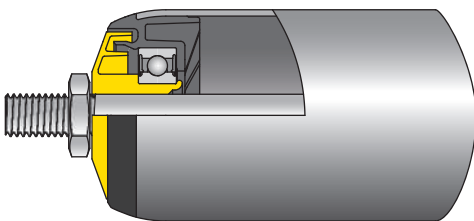

Male threaded shafts are made of round material.

Male threaded shafts feature a thread cut onto the shaft ends. In each case, a nut is screwed onto the shaft in front of the seal. The two nuts are subtracted from the dimension of the "lane width" during the production of the roller. They shorten the usable length of the roller compared to rollers with female threaded shafts.

- A firm connection causes a lot less noise than shafts that are not screwed together
- Very stable frame construction – generally, no use of crosslinks is required
- The roller shaft and side profile stabilize each other resulting in the conveyor rollers having a greater load capacity than loosely fitted rollers.
- Wear-free towards spring-loaded shafts due to firm connection in the side profile
- The two nuts at the seal and two nuts with washers for fastening are part of the scope of delivery
- Available only in the versions uncoated steel or stainless steel

### Flatted shaft

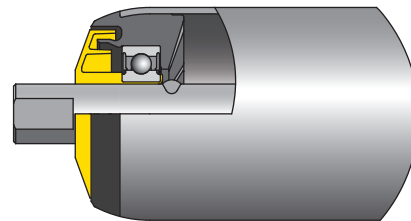

Flatted shafts are made of round material. They have two lateral, parallel milled sections at the shaft ends, which fit into corresponding side profile holes, e.g. into side profiles with open longitudinal holes.

- Very fast and simple installation and removal
- Suitable crosslinks have to be provided between the side profiles to reinforce the conveyor.
- Lower noise level than spring-loaded shafts since only minor play is required (no oblique installation)

A flat shaft can be created on both sides as well as on one side only (D shaft). The flat shaft can be defined in increments of 0.5 mm. Minimum and maximum dimensions depend on the selected shaft diameter.

# GENERAL TECHNICAL INFORMATION

## SHAFTS

### Fixed shaft

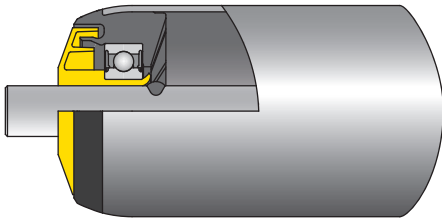

Fixed shafts can be manufactured from hexagon or round material. It is possible to fit the round shafts with a flat shaft. The shafts are mostly inserted in fastening holes in the side profile that are open at the top. To rule out that the shaft turns inside the guide of the side profile, Interroll recommends the use of hexagon shafts or round flattened shafts in corresponding side profiles intended for this purpose.

- Shields, or flat shafts if needed, are not zinc-plated for zinc-plated shaft material.
- Simple shaft design
- Very fast and simple installation and removal with fastening holes open to the top
- Suitable crosslinks have to be provided between the side profiles to reinforce the conveyor
- With driven rollers, play between the shaft and the mounting hole will create noise, particularly when starting and stopping the turning motion. For this reason, Interroll recommends the lowest play possible.

### Installation instructions

The following should be considered in relation to the selection of a shaft and construction of the side profiles:

1. The hole dimension of the side profile should be as small as possible on conveyor rollers with female threaded shafts. Larger holes can lead to a higher tolerance of the roller pitch and to the height differences of several conveyor rollers. The function of the roller conveyor can be affected by the hole and screw selection.
2. For softer side profiles made out of aluminum or thick powder coatings, female threaded shafts should always be selected with the largest possible diameter and the smallest possible thread. This minimizes the risk of the shaft penetrating the aluminum profile.
3. The installation of conveyor rollers with spring-loaded shaft must be done in an oblique way. That is the spring-loaded shaft must be inserted in a hole of the side profile. Afterwards, the other roller end is moved from an oblique to a horizontal position. The spring-loaded shaft can be inserted into the hole on the opposite side only in the horizontal position. Too small a hole could make installation significantly more difficult.

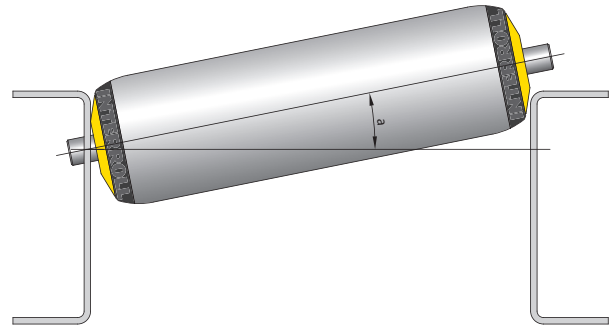

The following formula and the drawings should provide support in sufficiently dimensioning the fastening hole. For this purpose, an oversize of 0.5 mm of d1 compared to the shaft diameter is sufficient in most cases. In case of side profiles with different heights, the dimension H of the higher profile must always be used for the calculation.

$$d1 = \frac{S \cdot (H + D/2)}{(EL - 1)} + d$$

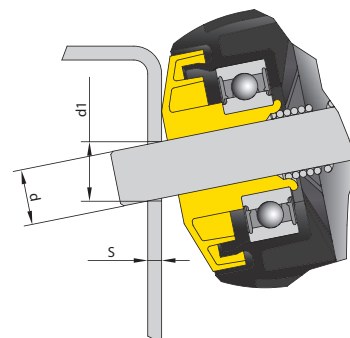
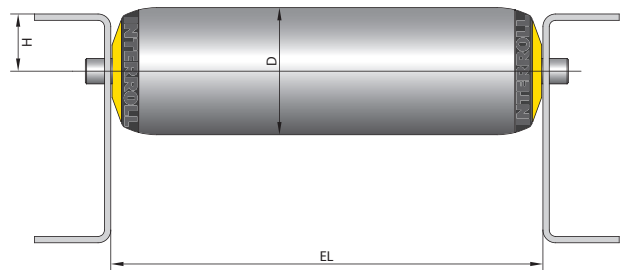

### Scope of delivery

Material required for fastening the rollers is not part of the scope of delivery, such as washers, nuts, screws.

### Exceptions

Product	Scope of delivery
Rollers with male threaded shafts	Nuts and washers
Rollers of series 3500KXO light	Taper disks and ball sockets

### Labeling

All shafts starting with a length of 100 mm are labeled with the respective production order number. The number is located on the shaft inside the tube. It allows users to order an identical roller without having to provide information about the product, such as the length.

### Axial play

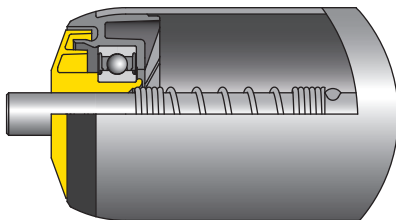

Conveyor rollers must not be warped during installation or operation. This means that play must exist between the seal of the roller and the side profile. The roller must move in axial direction under load.

The axial play must not be too high. Rollers with tapered shaft-shuttle or RollerDrive with tapered spring-loaded shaft are designed so that they have the best possible fit for the hole in the side profile, even in cases of high hole tolerances. This reduces wear and possible noise. If the axial play is too high, it may pose the risk of insufficient positioning of the hexagon in the hole, which leads to wear and noise.

The maximum play is already taken into account during the manufacture of the rollers.

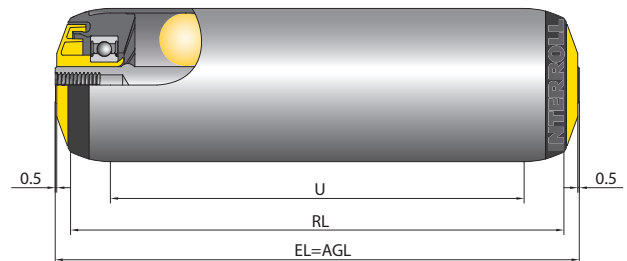

Example: At the time of ordering, a lane width (EL = installation length) of 500 mm is specified for a roller of series 1700 with female threaded shaft. The dimension from seal to seal measures approx. 499 mm. Hence, the roller has an axial play of approx. 1 mm (see figure above).

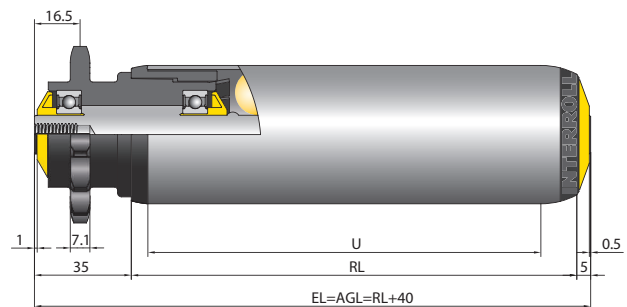

The axial play under consideration depends on roller series and roller version. For example, an axial play of approx. 1 mm on the drive side and 0.5 mm on the other side is taken into account for a roller of series 3500 with sprocket head (see figure above).

The axial play stated is only a guide value. There may be slight deviations from this figure in individual cases when production tolerances are added. The function of a correctly installed and used conveyor roller is not being impacted.

### Variable shaft length

A deviation of the standard shaft length is possible for all roller series. The shafts can be shortened or lengthened. The axial support of a roller via the seal must be ensured at all times. For some roller series, this requires taking appropriate measures in case of a shaft lengthening.

A length change is possible for the following shaft versions:

- Female threaded shaft
- Male threaded shaft
- Fixed shaft
- Spring-loaded shaft
- Flatted shaft



# GENERAL TECHNICAL INFORMATION

## TUBES

The length changes depend on the actual shaft version. Please direct any questions to your Interroll contact person. Axial support by the seal may no longer be guaranteed with a length change. With greater axial forces, e.g. where there is lateral displacement, suitable replacement structures, such as spacing tubes, may have to be fitted.

With female threaded shafts, the shaft can be lengthened only if the seal is given an axial support. Depending on the thread and shaft diameter, a retaining ring can be inserted. The retaining ring is secured via a groove incorporated in the shaft. The combination of a female threaded shaft with flatted shaft also requires a support of the seal.

In case of a shaft lengthening, the maximum load capacity of the roller is reduced compared to the values that are specified for each side.

### Shaft adapter

The shaft adapter is a conductive polymer component that can be pressed onto roller shafts. It can be inserted in side profiles with open elongated holes. In this case, the roller is placed from the top. The shaft adapter significantly reduces the noise level compared to the pure steel shaft and increases the installation length of the roller. The shaft adapter is not an alternative to the tapered shaft-shuttle (page 13).

### Technical data

<b>Material</b>	Polyoxymethylene, RAL9005 (jet black)
<b>Temperature range</b>	0 to + 40 °C
<b>Suitable shafts</b>	Fixed round shafts (Ø 8 and 10 mm)
<b>Anti-static version</b>	< 10 <sup>6</sup> Ω
<b>Max. static load of a roller with the use of shaft adapters</b>	See load capacity in the corresponding table (load capacity is not reduced by shaft adapter)

### Design versions

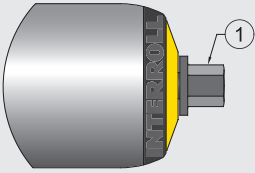
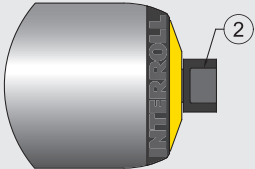
Shaft diameter [mm]	Drawing	Longer installation length [mm]
8		+5
10		+4

- 1 Adapter 11 HEX (hexagon)  
2 Adapter flat shaft 12

The shaft adapter can be used with the following roller series:

- Series 1100
- Series 1700
- Series 3500 (for drive heads for belts)

## Tubes

### Tube materials/tube diameters

#### Steel/stainless steel

The steel tubes used by Interroll are manufactured in accordance with DIN EN 10305-1, DIN EN 10305-3 and DIN EN 10305-7, but with stricter tolerance specifications.

The roller manufacturing and transport may result in minor scoring or scratches to appear on the tube surface. However, they do not have any effect on the functionality of the roller.

## Benefits

- Highest resistance and bending stiffness
- Steel – corrosion protection through zinc-plating or carbonitriding
- Stainless steel – very good and long-life corrosion protection
- Stainless steel – Application also possible in aggressive environments (not suitable for seawater)
- Sprockets and flanges can be welded on (flanges not together with stainless steel tube)
- Steel tubes can be flanged over the bearing assembly so that the bearing housing can no longer move out (not for carbonitrided tube as well as tubes with a wall thickness greater than 1.5 mm)

## Versions

- With grooves (not for carbonitrided tube)
- Covered with PVC or PU sleeve
- With lagging
- With pushed-on tapered elements
- With flanges welded on

When used in belt conveyors, there is noise caused by the pared tube welds coming into contact with the belt. Interroll recommends testing the relevant application.

## Aluminum

Aluminum tubes have slightly lower strength and only about 33 % of the flexural strength of steel tubes. However, they weigh only 36 % of the weight of comparable steel tubes.

## Benefits

- Significantly lighter than steel tube
- Corrosion-resistant
- Aluminum tubes can be flanged over the bearing assembly so that the bearing housing can no longer move out

## Versions

- Covered with PVC or PU sleeve
- With pushed-on tapered elements

Ø Rollers [mm]	Anodized surface	Anti-static version
20	Yes	No
50	No	Yes

## PVC

### Benefits

- Noise-dampening
- Highly impact-resistant
- Very lightweight
- Corrosion-resistant, no surface treatment required
- Easy to clean

Polymer tubes have a significantly lower load capacity compared with steel and aluminum tubes with the same diameter.

With polymer tubes with a diameter of 30 mm and larger, the bearing assemblies are connected form-fit with the tube so that an absolutely safe seating is ensured.

An ambient temperature range from -5 to +40 °C applies to polymer tubes. With a high ambient temperature (from 30 °C) and high continuous static load (over hours), a permanent deformation of the rollers cannot be ruled out.

When dimensioning the rollers for an existing width between the side profiles (lane width), a thermal expansion must be taken into account. In case of large temperature differences, the length of the roller changes based on the following formula:

$$\Delta L T = \frac{0,08 \cdot L \cdot \Delta T}{1000}$$

- ΔLT = change in length due to temperature change (mm)
- ΔT = temperature difference (°C)
- L = tube length (mm)

A proper functioning requires that a warping of the roller at high temperature is being avoided.

### Versions

- Covered with PVC or PU sleeve

Polymer tubes are available in the following colors:

Color	RAL number	Ø Tube [mm]
Stone gray	7030	16, 20, 30, 40, 50, 63
Graphite gray	7024	20
Sky blue	5015	50

# GENERAL TECHNICAL INFORMATION

## TUBES

### Tube diameter

The following overview lists all available shell diameters and their wall thicknesses. The respective shell series chapter describes which diameter is available in which material.

Ø Tube [mm]	Wall thicknesses [mm]
16	1.0
20	1.5
30	1.2; 1.8
40	1.5; 2.3
50	1.5; 2.8; 3.0
51	2.0
60	1.5; 2.0; 3.0
63	3.0
80	2.0; 3.0
89	3.0

### Finishing of shell materials

Material	Surface finishing
Steel	Zinc-plating
Steel	Carbonitriding
Aluminum	Anodizing

### Zinc-plating

Galvanized zinc-plating of steel tubes is a cost-efficient corrosion protection.

### Application

- For dry application areas with normal temperatures
- Conditional suitability for environments with salt and humidity, e. g. installations in harbor areas or in sub-tropical countries
- Conditional suitability in applications with moist or wet materials

Besides zinc-plated tubes, Interroll also offers zinc-plated shafts and zinc-plated sprocket heads. Front sides of shafts cannot be zinc-plated.

### Procedure

The surface of the steel tube material is galvanically zinc-plated (using electrolysis). The electrolysis produces an extremely even, thin sleeve. The entire process involves pre-treatment, zinc-plating, passivating and drying.

### Properties

Zinc-plated tubes are suitable for flanging and applying grooves. The galvanized zinc-plating is a temporary protection of the steel tube against corrosion.

The duration of the corrosion protection is reduced by the mechanical and thermal loads to which it is subjected. Particles of the zinc layer may be carried off when transporting materials over zinc-plated steel rollers.

Zinc-plated surfaces are sensitive to scratching and abrasion. Damage can result in point corrosion.

Extreme changes in temperature must be avoided as they can cause internal tension. Furthermore, corrosion resistance becomes reduced as the temperature rises.

In order to maintain the limited protective effects of zinc-plating, special packaging must be used for sea freight, for example.

Special measures must also be employed if the materials are to be stored for a longer period of time. Zinc-plating is not food-compatible.

A zinc-plated and passivated surface reacts with the following substances:

- Humidity
- Acidic environment (exhaust fumes, salts, wood acid etc.)
- Alkaline substances (lime, chalk, cleaning agents, CO<sub>2</sub>)
- Perspiration
- Solutions of other metals (copper, iron etc.)

<b>Layer thickness</b>	6 to 15 µm
<b>Passivation</b>	Additional blue passivation (chromium(IV)-free)
<b>Standards complied with</b>	DIN EN ISO 2081 DIN 50961 Zinc-plating according to RoHS regulations
<b>Temperature range</b>	-40 to +200 °C
<b>Antistatic</b>	Yes

The long material is zinc-plated. When the tube is sawed off, the front sides are not zinc-plated.

### Carbonitriding

Carbonitriding is a wear-resistant corrosion protection for steel tubes.

## Application

- For highly stressed conveyor rollers, e.g. from the transport of steel containers
- For applications where materials must be transported axially on rollers

## Procedure

Carbonitriding is a thermochemical process. For this purpose, the surface of the tube is enriched with nitrogen which creates a wear-resistant ceramic coating.

## Properties

Carbonitrided tubes are partially suitable (up to 1.5 mm wall thickness) for flanging, but not for the application of grooves.

The ceramic coating is a temporary protection of the steel tube against corrosion. It is resistant to scratching and chafing. Mechanical damage can result in point corrosion.

In addition, carbonitriding distinguishes itself with the following properties:

- Abrasion-resistant surfaces
- Good sliding properties
- Excellent temperature resistance
- Low warpage
- Free of scales
- Good corrosion resistance

The ceramic coating is not food-compatible. The carbonitrided surface does not create any abrasion, but can leave color traces behind.

A carbonitrided surface can react with the following substances:

- Acidic environment (exhaust fumes, salts, wood acid etc.)
- Alkaline substances (lime, chalk, cleaning agents, CO<sub>2</sub>)
- Perspiration
- Solutions of other metals (copper, iron etc.)

<b>Tube color</b>	Matt, light gray, and scale-free (no grinding necessary/possible)
<b>Min. reference length</b>	100 mm
<b>Max. reference length</b>	2000 mm
<b>Temperature range</b>	-40 to +80 °C
<b>Antistatic</b>	Yes

Carbonitriding is performed on the tube section that has already been cut to the correct length. This will also carbonitride the front sides.

## Anodizing

Anodizing is a corrosion protection for aluminum tubes.

## Application

- For weight-sensitive applications, e.g. shuttle systems
- For aluminum tubes with 20-mm diameter

## Procedure

The surface of the aluminum tube is given an oxidic protective coating. Compared to galvanizing procedures, the top material layer is transformed and an oxide is formed.

## Properties

The duration of the corrosion protection is reduced by the mechanical and thermal loads to which it is subjected. Particles may be carried off when transporting materials over anodized rollers.

Anodized surfaces are low-sensitive to scratching and abrasion. Mechanical damage can result in point corrosion.

An anodized surface can react with solutions of other metals, such as copper, iron, etc.

<b>Layer thickness</b>	≥ 20 µm
<b>Tube color</b>	Aluminum color (natural)
<b>Standards complied with</b>	DIN 17611, DIN EN 754/755
<b>Temperature range</b>	-40 to +80 °C
<b>Antistatic</b>	No

The rod material is anodized. When the tube is sawed off, the front sides are not anodized.

## Comparison

The different finishings of steel tube have different resisting forces compared to mechanical wear. The following table provides a factor that shows the reduction in wear of the tube surface compared to the steel zinc-plated version.

Material/finishing	Factor
Zinc-plated steel	1
Stainless steel	5
Steel carbonitrided	120

A carbonitrided surface is 120 times as resistant as a zinc-plated surface.

# GENERAL TECHNICAL INFORMATION

## TUBES

### Tubes with grooves

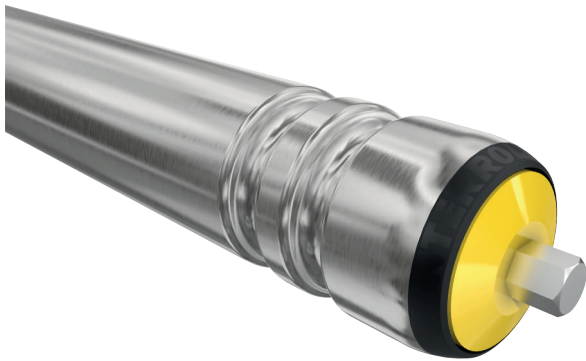

Grooves are running grooves that can be placed in steel tubes. They are used to guide round belts. When using the corresponding round belt, they are below the roller surface and, as such, do not contact the conveying good.

When the round belt is moved, the conveyor roller also moves. Two options are differentiated here:

- Wrapping from roller to roller
- Wrapping of a driven shaft that is positioned below the conveyor rollers. The guide rollers required for guiding the round belts on the drive shaft are located on Series 2600.

Grooves can be applied for the following roller and RollerDrive series:

Roller or RollerDrive series		Catalog page
Universal conveyor roller	1700	page 58
Universal conveyor roller	1700 heavy	page 72
Tapered universal conveyor roller	1700KXO	page 66
RollerDrive	EC5000	–

For tapered universal conveyor rollers, the tube must be longer than the tapered elements. The grooves are applied to this tube extension.

Please contact your Interroll contact person if grooves need to be applied to other roller series.

Rollers with grooves always contain an antistatic element. The maximum conveyor force of the round belt measures 300 N. The maximum load capacity per conveyor roller with groove measures 300 N due to the low conveyor force of the round belt.

The load capacity information in the individual roller series refers to rollers without grooves.

The maximum load capacity of the conveyor roller is lower with tube lengths of greater than 1400 mm. Interroll recommends a shaft version that is secured against twisting for round belt drives, such as a female threaded shaft. Grooves can be applied to tubes with a wall thickness of up to 2 mm.

It is possible to apply one to four grooves for each tube. The dimensions A and up to D, as needed, must be specified accordingly at the time of ordering. Version-dependent limitations of the groove positions are located in the respective chapters of the roller and RollerDrive series.

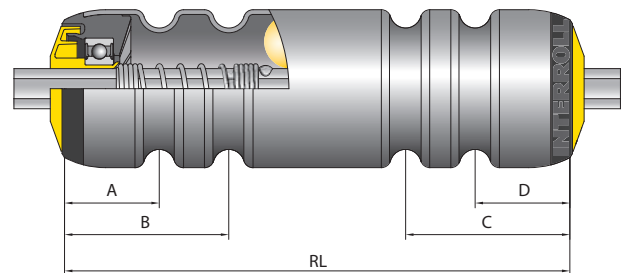

Grooves reduce the concentric precision and load capacity of conveyor rollers. Interroll recommends conveyor rollers with round belt drive heads or PolyVee drive heads of the Series 3500 to ensure that concentric precision is adhered to (page 80).

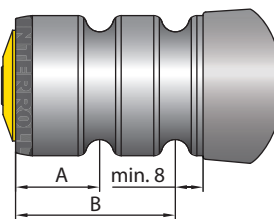

### Concentric precision

Conveyor rollers and RollerDrive are manufactured from tubes according to DIN standard. This standard allows deviations in form and straightness, which give rise to the concentric precision.

The concentric deviation is the maximum radial deviation of the diameter of the tube from a perfect circle.

Example: A concentric deviation  $t = 0.3$  mm means that the maximum radial deviation of the entire tube is 0.3 mm.

# GENERAL TECHNICAL INFORMATION STRAIGHTENED ROLLERS / ROLLER LENGTHS

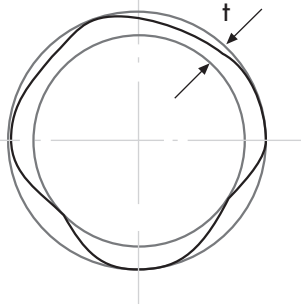
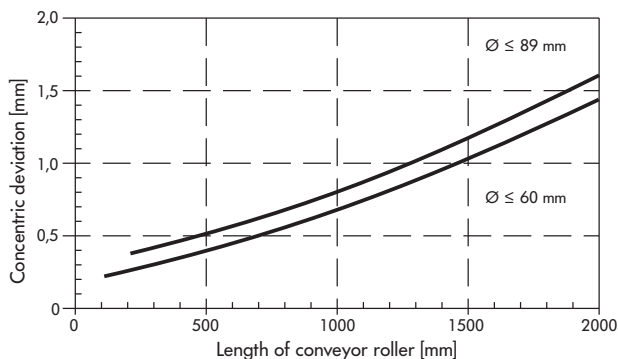

Fig.: Concentric deviation t

In principle, concentric deviation depends on the length and material of the tube. It is all the greater the longer a tube is, especially with polymer tubes.

The average concentric deviation of Interroll rollers can be found in the following diagrams.

## Steel tubes



## Polymer tubes

With polymer tubes, the concentric deviation increases disproportionately to the length of the tube. The following lengths should not be exceeded:

Ø Tube [mm]	Max. tube length [mm]
16	300
20	400
30	500
40/50	600
63	800

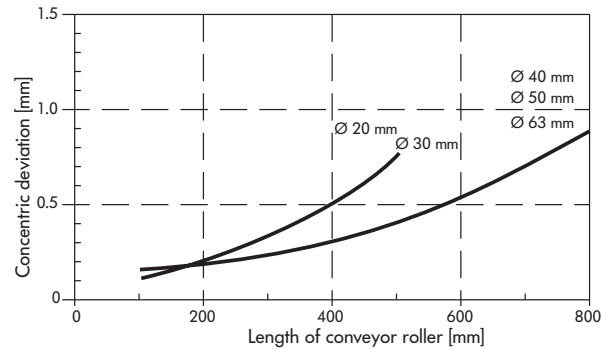

For steel tubes  $\leq 2$  mm wall thickness, Interroll offers a 100% check. In the process, the concentric precision of every roller ordered is checked and, if needed, the tube is straightened. Carbonitrided tubes cannot be straightened.

Please note that DIN-compliant tubes are permitted significantly higher concentric tolerances. For this reason, the empirically determined guide values represented in the diagrams can be exceeded in individual cases.

## Straightened rollers / roller lengths

In principle, the rollers manufactured by Interroll have a high concentric precision. The concentric precision is sufficient for almost all applications. On top of that, Interroll offers a 100% inspection for rollers made out of steel.

During the inspection, the concentric precision of each roller is measured. If the concentric precision falls outside the specified tolerance (page 20), the tube is straightened. The concentric deviation is corrected only if it falls outside the tolerance.

When measuring the concentric precision and also for the straightening process, the tube is the reference point. The concentricity between shaft and tube is not checked.

# GENERAL TECHNICAL INFORMATION

## PVC SLEEVE

### Technical data

Straightening is possible for tubes with a thickness up to 2 mm made of uncoated steel, zinc-plated steel, stainless steel, aluminum, and anodized aluminum.

Straightening is possible for the following tubes or tube lengths:

Ø Tube [mm]	Tube wall thickness [mm]	Min. length [mm]	Max. length [mm]
16	1	300	1000
20	1.5	490	1200
30	1.2	400	1200
40	1.5	600	1700
50	1.5	800	2000
51	2	600	1500
60	1.5	1000	2000
80	2	1500	2000

Straightening is possible for rollers with the following features:

- Rollers with grooves
- Rollers with flange
- Rollers with sleeve or lagging
- Rollers with tapered elements
- Carbonitrided rollers and PVC rollers

### Roller lengths

The Interroll conveyor rollers can be manufactured in different lengths utilizing millimeter increments. Most versions can be manufactured starting at a length of approx. 200 mm. The longest dimension for many series is approx. 2000 mm. The shortest and longest dimension depends on many factors, such as shaft design, tube material, production process or packaging options.

### Definitions

- RL = Reference length/ordering length
- EL = Installation length, inside diameter between side profiles
- AGL = Total length of shaft
- U = Usable tube length, length without bearing housing and for flanged metal tube without length of flanging

For conveyor rollers with female threaded shaft, the total shaft length corresponds to the installation length.

The installation length can be measured via the total shaft length only for rollers with female threaded shaft. For all other shaft designs, the installation length cannot be measured precisely at the conveyor roller. The axial play of approx. 0.5 mm or at the driven sides of approx. 1 mm is part of the installation length and does not allow an exact measurement of the installation length.

The reference length/ordering length has measurable reference edges on the conveyor roller for the following series:

- 1100
- 1700
- 1700 light (exception: Ø 20 mm)
- 3500 light
- 3500
- 3500 heavy
- 3800

### PVC sleeve

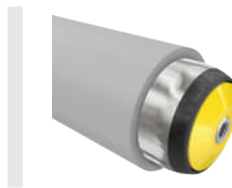

The PVC sleeve ensures a particularly high noise reduction and offers a high level of protection for sensitive conveying goods. An improved conveyance of conveying goods is achieved with the higher coefficient of friction compared with a steel tube. Conveying goods can easily be separated since the larger diameter leads to a higher speed with the same rotational speed.

# GENERAL TECHNICAL INFORMATION

## PVC SLEEVE

### Technical data

General technical data	
Min. sleeve length	50 mm
Temperature range	-28 to +50 °C Risk of fracture when cold starting at -30 °C
Material	
Tube	PVC, zinc-plated steel, stainless steel, aluminum
PVC sleeve	<ul style="list-style-type: none"> <li>• RAL7030 (stone gray) or RAL9005 (black)</li> <li>• Soft PVC, RAL7030 (stone gray)</li> <li>• Silicone-free</li> <li>• RoHS-compliant</li> <li>• REACH-compliant</li> <li>• Not food-safe</li> <li>• Non-conductive</li> <li>• Not oil or gasoline-resistant</li> </ul>
Sleeve hardness	62 + 5 Shore A (at 20 °C); the hardness increases at lower temperatures

Tapered RollerDrive cannot be fitted with a PVC sleeve.

### Design versions

#### PVC sleeve, stone gray

Ø Tube [mm]	Sleeve material thickness [mm]	
30	2	5
40	2	5
50	2	5
60	2	5
80	2	

#### PVC sleeve, black

Ø Tube [mm]	Sleeve material thickness [mm]	
50	2	

The PVC sleeve is not glued onto the conveyor roller. The conveyor roller is pushed into the sleeve widened with compressed air by using a pressing machine. Then the sleeve is cut to the length of the tube or to the specified dimension.

Conveyor rollers with welded drive element can also be fitted with a PVC sleeve. This requires a drive element whose diameter is not greater than 12 mm of the tube.

Friction rollers (Series 3800, 3800 light, 3870) can be fitted only with 2-mm PVC sleeve. Rollers with PVC sleeve are always designed with an antistatic element. The PVC sleeve is not antistatic.

### Dimensions

The PVC sleeve generally covers the entire tube length. It is possible not to fit sections of the roller with the PVC sleeve, e.g. the free space for grooves. A minimum length of 50 mm is required for a firm seating of the sleeve. With existing axial forces, a greater minimum length must be selected.

When ordering a roller or RollerDrive with sleeve, always specify the dimensions A to D.

#### Split PVC sleeve and PolyVee drive head

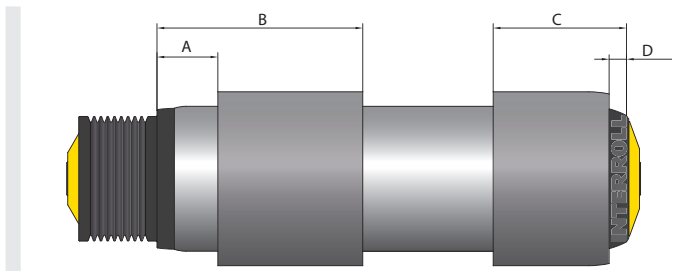

#### PVC sleeve with clean cuts

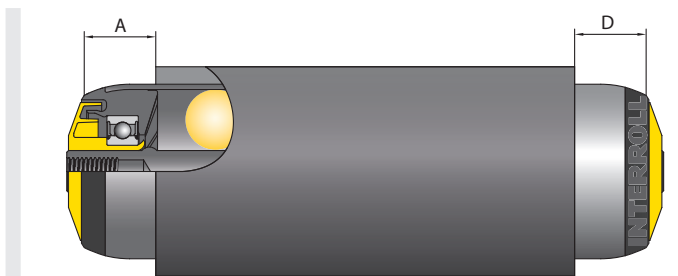



# GENERAL TECHNICAL INFORMATION

## PU SLEEVE

### PVC sleeve and 2 grooves

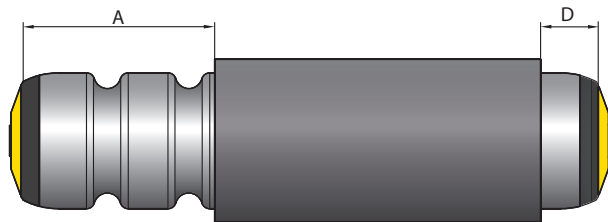

### PU sleeve

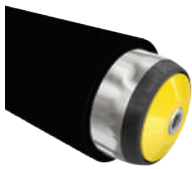

The PU sleeve ensures a high level of noise reduction, particularly for steel containers, and offers a high level of protection of sensitive conveying goods. An improved conveyance of conveying goods is achieved with the higher coefficient of friction compared with a steel tube. Conveying goods can easily be separated since the larger diameter leads to a higher speed with the same rotational speed. With mechanical stress, e.g. with abrasion, it offers a higher robustness than a PVC sleeve.

### Technical data

Tapered rollers cannot be fitted with a PU sleeve.

General technical data	
Min. sleeve length	50 mm
Temperature range	-28 to +80 °C
Material	
Tube	Zinc-plated steel, stainless steel, aluminum
PU sleeve	<ul style="list-style-type: none"> <li>• Polyurethane, RAL9005 (jet black), gloss</li> <li>• Softener-free</li> <li>• Silicone and halogen-free</li> <li>• FDA-compliant</li> <li>• RoHS-compliant</li> <li>• Non-conductive</li> <li>• Oil or gasoline-resistant</li> </ul>
Sleeve hardness	75 + 5 Shore A (at 20 °C); the hardness increases at lower temperatures

### Design versions

Ø Tube [mm]	Sleeve material thickness [mm]
50	2
51	2

With the lower elasticity, the PU sleeve cannot be applied to any other tube diameters or tubes with welded-on elements.

The PU sleeve is not glued onto the conveyor roller. The conveyor roller is pushed into the sleeve widened with compressed air by using a pressing machine. Then the sleeve is cut to the length of the tube or to the specified dimension. Rollers with PU sleeve are always designed with an antistatic element. The PU sleeve is not antistatic.

## Dimensions

The PU sleeve generally covers the entire tube length. It is possible not to fit sections of the roller with the PU sleeve, e.g. the free space for grooves. A minimum length of 50 mm is required for a firm seating of the sleeve. With existing axial forces, a greater minimum length must be selected.

When ordering a roller with sleeve, always specify the dimensions A to D.

## Split PU sleeve and PolyVee drive head

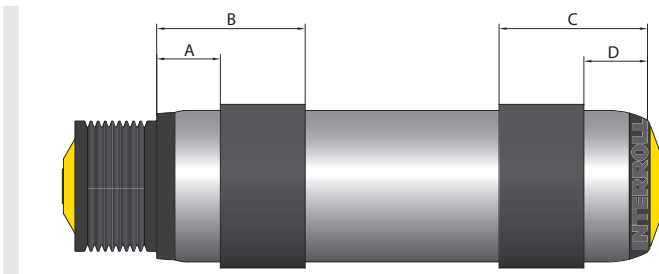

## Lagging

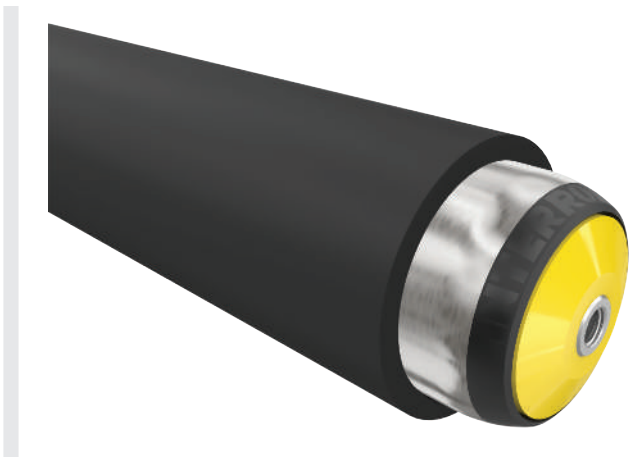

The lagging ensures a high level of noise reduction and offers a high protection of medium-heavy to heavy conveying goods. An improved conveyance of conveying goods is achieved with the higher coefficient of friction compared with a steel tube. Conveying goods can easily be separated since the larger diameter leads to a higher speed with the same rotational speed. The lagging offers a high robustness under mechanical stress and is very abrasion-proof. Compared to sleeves, that are not connected to the tube, axial forces are also allowed.

## Technical data

General technical data	
Max. reference length of the roller	1350 mm
Temperature range	-30 to +80 °C
Material	
Tube	<ul style="list-style-type: none"> <li>• Uncoated steel</li> <li>• Stainless steel</li> </ul>
Black lagging	<ul style="list-style-type: none"> <li>• Nitrile rubber</li> <li>• Silicone- and halogen-free</li> <li>• Good resistance to alkalis</li> <li>• RoHS-compliant</li> <li>• Not FDA-compliant</li> <li>• Not antistatic</li> <li>• Oil, grease or gasoline-resistant</li> <li>• Not resistant to aromatics</li> <li>• Hardness 65 ± 5 Shore A</li> </ul>
White or blue lagging	<ul style="list-style-type: none"> <li>• Nitrile rubber</li> <li>• Silicone- and halogen-free</li> <li>• Good resistance to alkalis</li> <li>• RoHS-compliant</li> <li>• FDA-compliant</li> <li>• Not antistatic</li> <li>• Oil, grease or gasoline-resistant</li> <li>• Not resistant to aromatics</li> <li>• Hardness 70 ± 5 Shore A</li> </ul>

Tapered RollerDrive cannot be fitted with a lagging.

# GENERAL TECHNICAL INFORMATION

## LAGGING

### Design versions

For tube diameters 40, 50, 51, 60, 80 and 89, a lagging of 2 to 5 mm thickness in increments of 0.1 mm is possible.

Roller series	Ø Tube [mm]	Bearing housing of drive side/non-drive side	Min. distance of lagging to left/right reference length [mm]
1450	80	Flanged/Flanged	15/15
1450	89	Flanged/Flanged	15/15
1700	40	Flanged/Flanged	16/16
1700	50	Flanged/Flanged	16/16
1700	50	Cylindrical/Cylindrical	6/6
1700	51	Flanged/Flanged	16/16
1700	51	Cylindrical/Cylindrical	6/6
1700	60	Flanged/Flanged	16/16
1700	80	Flanged/Flanged	16/16
1700 heavy	50	Flanged/Flanged	16/16
1700 heavy	51	Flanged/Flanged	16/16
1700 heavy	60	Flanged/Flanged	16/16
3500	40	Cylindrical/Flanged	0/16
3500	50	Flanged/Flanged	21/21
3500	50	Cylindrical/Flanged	6/16
3500	50	Cylindrical/Cylindrical	6/6
RollerDrive	50	Cylindrical/Flanged	6/21
RollerDrive	50	Cylindrical/Cylindrical	6/6

The lagging is applied through hot vulcanization and reground. This creates a high-strength joint of the lagging with the tube, resulting in a surface that is highly resistant to abrasion and very precise. For uncoated steel material, projecting tube sections are protected against corrosion with a black paint coating. For welded drive heads, the tube and drive head remain untreated.

Friction rollers (Series 3800, 3800 light, 3870) can be fitted only with 2-mm lagging.

### Dimensions

#### Stainless steel tube with 2 grooves and split lagging

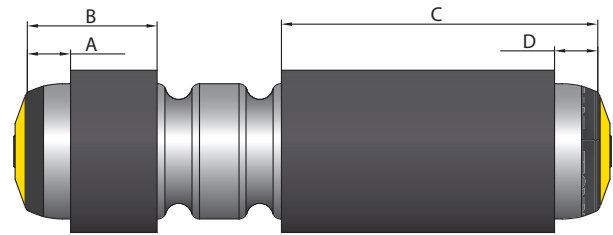

#### Uncoated steel tube with 1/2" polymer double sprocket head with 14 teeth and lagging

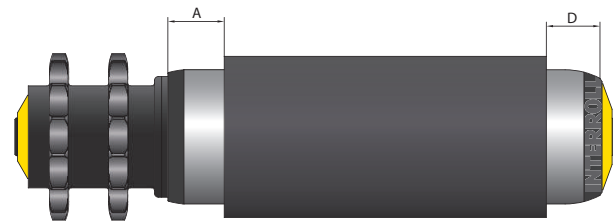

## Flanges

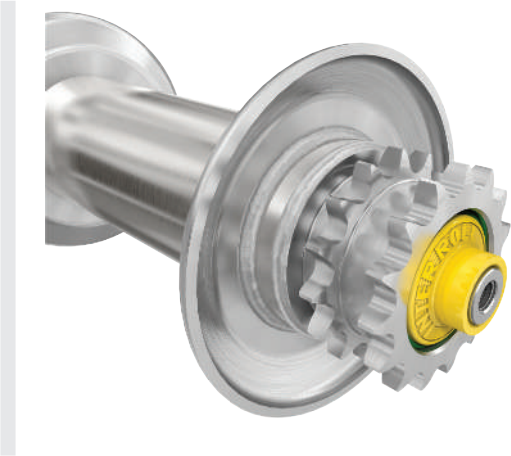

Flanges guide materials and prevent their lateral wandering. Circumferential welds ensure a high stability.

### Technical data

The number of flanges and the roller pitch has to be selected in such a way that at least two flanges always guide the material at any given time.

<b>Max. reference length</b>	1600 mm
<b>Material</b>	Zinc-plated steel, uncoated steel
<b>Max. number of flanges/rollers</b>	4
<b>Temperature range</b>	Depending on roller series

### Design versions

Ø Tube [mm]	Ø Flange, outside d2 [mm]	Flange material thickness s [mm]	Flange width b [mm]
50	75	3	8.5
60	100	3	8.5
80	150	4	18.0
89	150	4	18.0

The following roller series can be delivered with flanges:

- 1200
- 1450
- 1700
- 1700 heavy
- 3500
- 3500 heavy
- 3950

### Dimensions

When ordering a roller with flange, always specify the dimensions A to D.

#### Flange

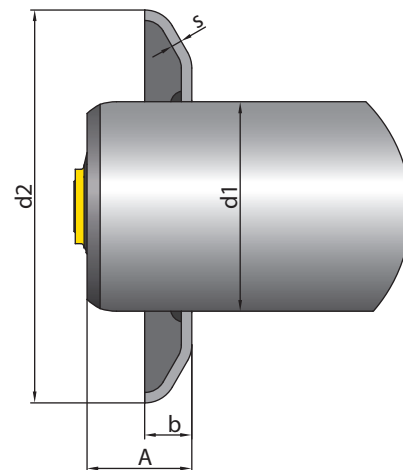

Fig.: Left flange

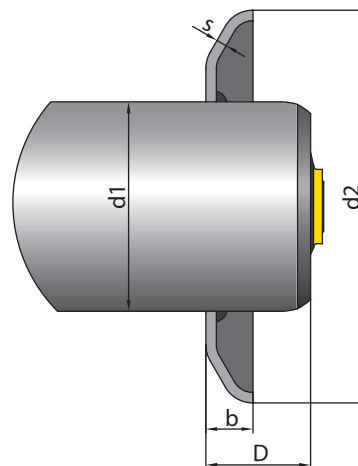

Fig.: Right flange

# GENERAL TECHNICAL INFORMATION

## ANTISTATIC ELEMENT

### Series 1450, 1700 and 1700 heavy with 2 flanges

d1 [mm]	d2 [mm]	s [mm]	b [mm]	A <sub>min</sub> [mm]	D <sub>min</sub> [mm]
50	75	3	8.5	23	23
60	100	3	8.5	23	23
80/89	150	4	18	25	25

### Series 3500

d1 [mm]	d2 [mm]	s [mm]	b [mm]	A <sub>min</sub> [mm]	D <sub>min</sub> [mm]
50	75	3	8.5	20	23
60	100	3	8.5	20	23

### Series 3500 heavy

d1 [mm]	d2 [mm]	s [mm]	b [mm]	A <sub>min</sub> [mm]	D <sub>min</sub> [mm]
60	100	3	8.5	20	23

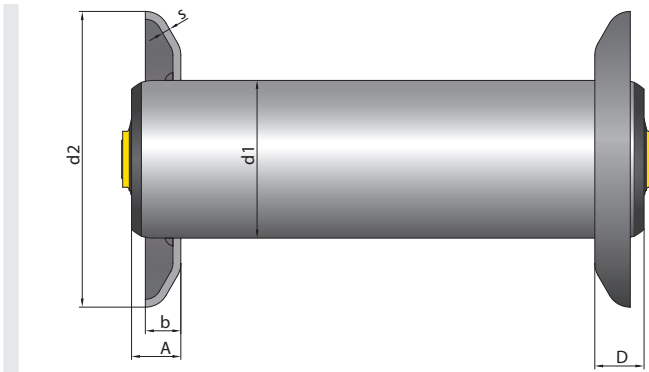

## Antistatic element

The antistatic element creates a permanent electrical connection between the metal tube and the shaft of the roller. If the side profile is grounded accordingly and an electrical connection is established between the shaft of the roller and the side profile, no static charge is created on the metal tube surface.

The antistatic element can be applied for the following tube materials or tube finishings:

Material	Surface finishing
Steel	None
Steel	Zinc-plating
Steel	Carbonitriding
Stainless steel	None
Aluminum	None (no anodic oxide layer)

### Series 3950 with 2 flanges

d1 [mm]	d2 [mm]	s [mm]	b [mm]	A <sub>min</sub> [mm]	D <sub>min</sub> [mm]
80/89	150	4	18	23	25

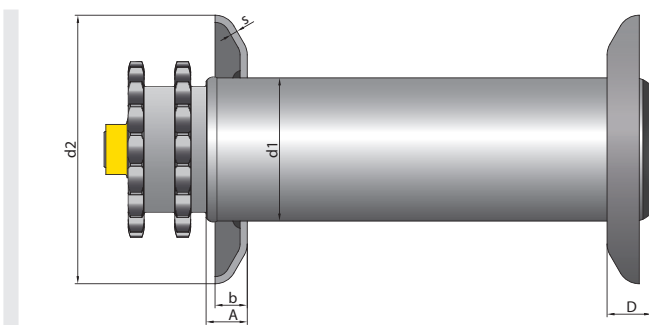

By default, the antistatic element is applied for all conveyor rollers with integrated groove, all polymer-based drive heads, tube sleeves, and tapered elements and can be selected as an option for the following roller series:

### Series 1200

d1 [mm]	d2 [mm]	s [mm]	b [mm]	A <sub>min</sub> [mm]	D <sub>min</sub> [mm]
50	75	3	8.5	23	23
60	100	3	8.5	23	23

- Series 1100
- Series 1450
- Series 1700 light
- Series 1700
- Series 1700KXO
- Series 1700 heavy
- Series 3500
- Series 3500KXO light
- Series 3500KXO
- Series 3950

# GENERAL TECHNICAL INFORMATION TUBES WITH NOISE REDUCTION

The antistatic element is available for the following roller diameters:

- 20 mm
- 30 mm
- 40 mm
- 50 mm
- 60 mm
- 80 mm
- 89 mm

- Series 1500
- Series 1700
- Series 1700 heavy
- Series 3500

Rollers with noise reduction are fitted with a foam inner tube. The foam is pressed into the tube during the production process of the roller. The noise reduction is also possible for rollers with grooves.

Interroll recommends to ensure the electrical connection of the roller shaft to the side profile and to check the grounding potential on the roller surface before and after the use of the roller. Threaded shafts are best suited to establish a reliable electrical connection.

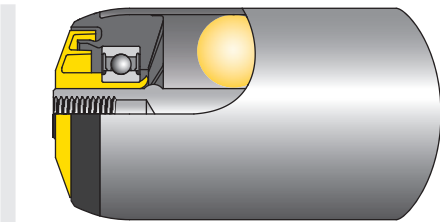

## Tubes with noise reduction

### Benefits

- High noise reduction, particularly with steel containers
- Reduces the frequency level and resonance when the rollers hit the end stop

### Technical data

<b>Min. reference length for attenuation</b>	250 mm
<b>Max. reference length for attenuation*</b>	2000 mm
<b>Ø Tube</b>	50 mm
<b>Temperature range</b>	-28 to +80 °C
<b>Tube Materials</b>	Uncoated steel, zinc-plated steel, stainless steel, aluminum

\* The insulating material is inserted in the tube with a maximum length of 1,000 mm. This length is sufficient for noise reduction.

### Design versions

The following series can be equipped with noise reduction:

- Series 1100
- Series 1200